

# OPERATING MANUAL

## **SOFTER**

**8 PS | 11 PS**

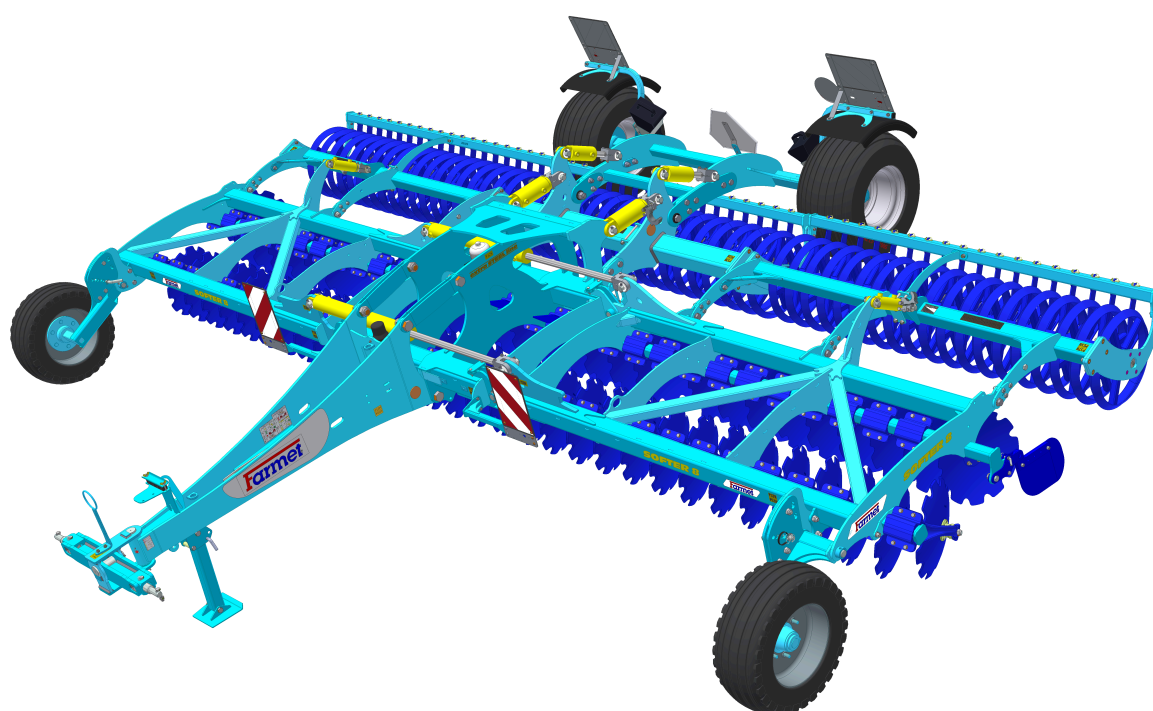

Edition: 9

Effective from: 01.01.2025

FARMET a.s.  
Jiřinková 276  
552 03 Česká Skalice, CZ

phone: +420 491 450 111  
GSM: +420 774 715 738

Id. No.: 46504931  
Tax Id. No.: CZ46504931

web: [www.farmet.cz](http://www.farmet.cz)  
e-mail: [dzt@farmet.cz](mailto:dzt@farmet.cz)

Prepared by: Technical Department, Farmet a.s.  
on 18.02.2025, changes reserved

# PREFACE

Dear customer,

The agricultural machine you have purchased is a high-quality product of Farmet a.s. Česká Skalice.

You can fully utilise the advantages of your machine after thoroughly studying the operating manual.

The serial number of the machine is punched on the production label and written in the operating manual (Your Machine Characteristics). This machine serial number must be stated whenever ordering spare parts for possible repairs. The production label is located on the frame .

Use only spare parts for these machines according to the **Spare parts catalogue** officially issued by the manufacturer, Farmet a.s. Česka Skalice.

### Possibilities of use of the machine

The **SOFTER** disc plough-harrow is intended for ploughing all types of soil up to the depth of 12 cm (4.7 in).

### Your Machine Characteristics :

MACHINE TYPE :  
 MACHINE SERIAL NUMBER :  
 SPECIAL DESIGN OR ACCESSORIES :

|  |
|--|
|  |
|  |
|  |

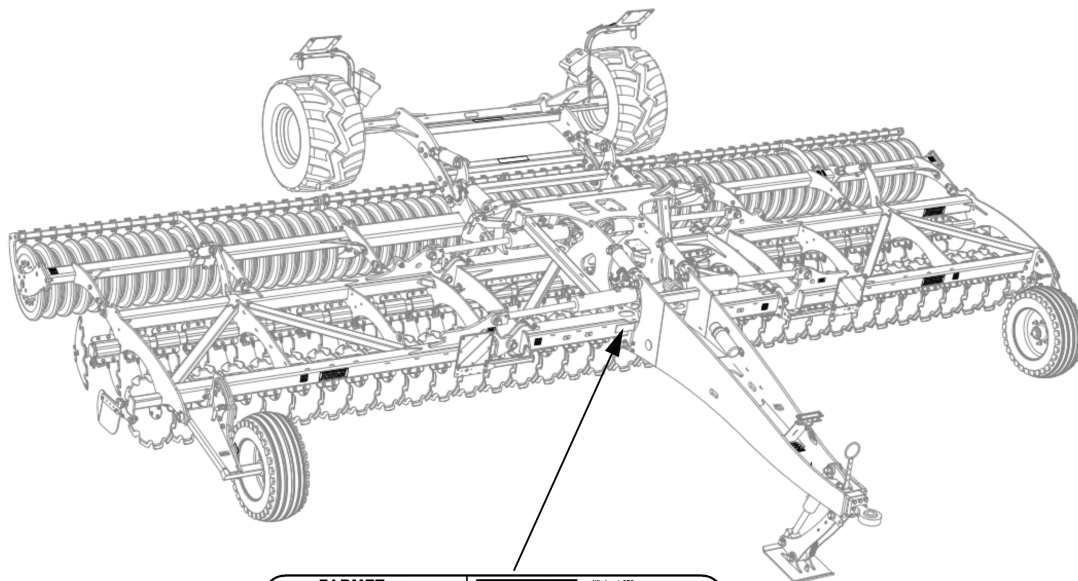

|                    |        |   |         |
|--------------------|--------|---|---------|
| FARMET a.s.<br>S2a |        | Jilinkova 276<br>552 03 Ceska Skalice<br>MADE IN CZECH REPUBLIC |         |
| ----               |        | SOFTER SF9PSW   |         |
| ROK/<br>YEAR       | 2020   | CELK. HMOTNOST/<br>TOTAL WEIGHT                                 | 7600 kg |
| kg                 | T-1    | T-2   | T-3     |
| B-1                | ---    | ---   | ---     |
| B-2                | ---    | ---   | ---     |
| B-3                | ---    | ---   | ---     |
| B-4                | ---    | ---   | ---     |
| FAR12585TL0000???  |        | www.farmet.cz   |         |
| 5280 kg            | CE EAC |   |         |
| A-0: 2320 kg       |        |   |         |
| A-1: 5280 kg       |        |   |         |
| A-2: --- kg        |        |   |         |
| A-3: --- kg        |        |   |         |

**IMPORTANT**

**READ CAREFULLY BEFORE USE**

**KEEP FOR FUTURE REFERENCE**

## Contents

|  |    |
|--|----|
| PREFACE .....  | 3  |
| 1 MACHINE LIMIT PARAMETERS .....                                 | 7  |
| 1.1 Technical parameters.....                                    | 8  |
| 1.2 Safety statement.....  | 8  |
| 2 GENERAL INSTRUCTIONS FOR USE .....                             | 9  |
| 3 MACHINE TRANSPORT USING TRANSPORT MEANS .....                  | 11 |
| 4 MACHINE HANDLING USING LIFTING EQUIPMENT .....                 | 12 |
| 5 WORK SAFETY LABELS .....                                       | 13 |
| 6 DESCRIPTION.....   | 17 |
| 6.1 Working parts of the machine .....                           | 17 |
| 6.2 Hydraulics.....  | 18 |
| 6.2.1 Closing (ball) valve function.....                         | 21 |
| 7 MACHINE ASSEMBLY AT THE CUSTOMER.....                          | 23 |
| 8 COMMISSIONING.....   | 24 |
| 8.1 Agregation to a tractor .....                                | 25 |
| 8.2 Hydraulics connection.....                                   | 27 |
| 8.3 Folding and unfolding of the machine.....                    | 28 |
| 8.3.1 Machine unfolding procedure.....                           | 30 |
| 8.3.2 Machine Folding Procedure.....                             | 32 |
| 9 MACHINE TRANSPORT ON ROADS.....                                | 34 |
| 9.1 Sharp machine projections .....                              | 36 |
| 10 MACHINE ADJUSTMENT .....                                      | 37 |
| 10.1 Adjusting the working depth of the machine .....            | 38 |
| 10.2 Drawbar for the bottom fixed hitch.....                     | 39 |
| 10.3 Adjusting the longitudinal plane of the machine .....       | 40 |
| 10.4 Setting side deflectors and edge discs.....                 | 42 |
| 10.5 Machine travelling direction at work .....                  | 43 |
| 11 MACHINE MAINTENANCE AND REPAIRS.....                          | 44 |
| 11.1 Maintenance plan .....                                      | 45 |
| 11.2 Machine lubrication shedule .....                           | 48 |
| 11.3 Replacement of the working roller bearings .....            | 49 |
| 11.3.1 Using the tool for bearing disassembly and assembly ..... | 50 |
| 11.3.2 Using spacers .....                                       | 54 |
| 12 MACHINE STORAGE.....  | 55 |
| 13 ENVIROMENTAL PROTECTION .....                                 | 56 |
| 14 MACHINE DISPOSAL AFTER SERVICE LIFE EXPIRY.....               | 57 |
| 15 SERVICING AND WARRANTY CONDITIONS .....                       | 58 |
| 15.1 Servicing.....  | 58 |
| 15.2 Warranty .....  | 58 |



## 1 MACHINE LIMIT PARAMETERS

- The machine is designed for soil ploughing up to a depth of 12 cm (4.7 in) when agricultural soil cultivation. Another type of use exceeding the determined purpose is forbidden.
- The machine is only operated by one person – the tractor driver.
- Machine operator must not use the machine in a different way, especially:
  - transport of persons and animals on the machine structure,
  - transport of burdens on the machine structure,
  - aggregation of the machine with another towing equipment than stated in Chapter 8.1.

### 1.1 Technical parameters

| PARAMETERS  |       | SOFTER 8 PS                     | SOFTER 11 PS                       |
|---|-------|---------------------------------|------------------------------------|
| Working width   |       | 7,4 m (25,1 ft)                 | 10,7 m (35,7 ft)                   |
| Transport width                                       |       | 3 m (9,84 ft)                   |                                    |
| Transport height                                      |       | 4 m (13,12 ft)                  |                                    |
| Machine total length                                  |       | 6,85 m (22,47 ft)               |                                    |
| Working depth   |       | 3,5–12 cm (1,38-4,72 in)        |                                    |
| Number of discs<br>ø510mm (ø20in) /<br>ø560mm (ø22in) | front | 31                              | 45                                 |
|   | rear  | 30                              | 44                                 |
| Working performance                                   |       | 8–12 ha/h<br>(19,8 – 29,6 ac/h) | 11–16,5 ha/h<br>(27,2 – 40,8 ac/h) |
| Towing means  |       | 200 – 300 kW<br>(270 – 405 HP)* | 245 – 370 kW<br>(330 – 495 HP)*    |
| Working speed   |       | 10–15 kph (6 - 9,5 mph)         |                                    |
| Maximum transport speed                               |       | 30 kph (18,6 mph)               |                                    |
| Maximum slope grade                                   |       | 6°                              |                                    |
| Tyre dimensions - transport<br>Tyre pressure          |       | 500/50-17<br>350 kPa (51 Psi)   |                                    |
| Machine weight  |       | 6 700 kg (14 771 lb)**          | 9 200 kg (20 283 lb)**             |

\* Recommended towing means, the real towing force may significantly vary according to the processing depth, soil conditions, land slope, working body wear and adjustment.

\*\* Weight with the LTX roller

### QUICK START



### 1.2 Safety statement



This warning sign warns about an immediate dangerous situation ending with death or severe injury.





This warning sign warns about a dangerous situation ending with death or severe injury.



This warning sign warns about a situation that may end with a smaller or slight injury. It also warns about dangerous actions related to the activity that could lead to an injury.



## 2 GENERAL INSTRUCTIONS FOR USE

- The machine is made in accordance with the latest equipment state and approved safety regulations. However, dangers of user or third person injury or machine damage or creation of other material damage may arise during use.
- Use the machine only in a technically sound condition, in accordance with its purpose, aware of possible dangers, and while adhering to the safety instructions of this operating manual !!!  
The Manufacturer is not liable for damages caused by the use of the machine that is in contradiction with the limit parameters of the machine and with the instructions for the use of the machine (Chapter 2 and 8). The User bears the risk.  
Immediately remove especially the failures that may negatively affect safety!
- Machine operation may be performed by a person authorised by the operator under these conditions:
  - It must own a valid driver's licence of the corresponding category,
  - It must be demonstrably familiarised with the safety regulations for work with the machine and must practically master the machine operation,
  - The machine may not be operated by juveniles,
  - It must know the meaning of the safety signs located on the machine. Their respecting is important for safe and reliable machine operation.
- Maintenance and servicing repairs on the machine may only be performed by a person :
  - Authorised by the operator,
  - Educated in the machinery field with knowledge of repairs of similar machines,
  - Demonstrably familiarised with safety regulations for work with the machine,
  - During a repair of a machine connected to a tractor, it must own a driver's licence of the corresponding category.
- Machine operator must secure the safety of other persons when working with the machine or transporting the machine.
- During machine work in the field or during transport, the operator must control the machine from the tractor's cabin.
-  The operator may enter the machine structure only with the machine at rest and blocked against movement, namely only for these reasons:
  - Adjustment of the machine working parts,
  - Repair and maintenance of the machine,
  - Release and securing of spherical valves of the axle,
  - Securing of spherical valves of the axle before folding the side frames,
  - Adjustment of the working parts of the machine after unfolding the side frames.
-  When climbing on the machine, do not step on the axle tyres, rollers, discs or other revolving parts. Those may turn and you can cause very serious injuries by the subsequent fall.
-  Any changes or modifications of machine may be performed only with written consent of the manufacturer.  
For possible damage arisen due to ignoring this instruction, the producer bears no responsibility.  
The machine must be maintained equipped with prescribed accessories and equipment including safety marking.  
All warning and safety signs must be legible and in their places. In case of damage or loss, these signs must be immediately renewed.

- The operator must have the Operating Manual with the work safety requirements available at any time when working with the machine.



- The operator must not consume alcohol, medicines, narcotic and hallucinogenic substances that decrease his attention and coordination capabilities while using the machine.  
If the operator must use medicines prescribed by a physician or uses freely sold medicines, he must be informed by a physician, whether he is capable of responsible and safe operation of the machine under these circumstances.

**Protective equipment :**

For operation and maintenance, you need :



- close-fitting clothes
- protective gloves and goggles against dust and sharp parts of the machine



### 3 MACHINE TRANSPORT USING TRANSPORT MEANS

- The transport means designed for machine transport must have the load capacity minimally identical with the weight of the transported machine. The total weight of the machine is stated on the production label.
- The dimensions of the transported machine including the transport means must comply with the valid regulations for road traffic (decrees, laws).
-  The transported machine must be always fastened to the transport means so that its spontaneous loosening could not happen.
- The carrier is responsible for damage caused by the loosening of incorrectly or insufficiently fastened machine to the transport means.

## 4 MACHINE HANDLING USING LIFTING EQUIPMENT

- The lifting equipment and tying means designed for handling of the machine must have their load capacity at least identical with the weight of the handled machine.
-  • Machine fastening for handling may only be performed in places designed for that and marked with self-adhesive labels showing the "chain" symbol. 
- After fastening (suspending) at designated points, it is forbidden to move in the space of possible reach of the handled machine.

## 5 WORK SAFETY LABELS

The warning safety labels protect the operating staff

The following applies in general :

- Strictly observe the warning safety labels.
- All safety instructions also apply to other users.
- If the "SAFETY LABEL" located on the machine gets damaged or destroyed, THE OPERATING STAFF MUST REPLACE THE LABEL WITH A NEW ONE !!!
- The position, appearance and the precise meaning of the work safety labels on the machine are defined in the following tables and the figure.

| WARNING SAFETY LABEL | LABEL TEXT   | MACHINE POSITION |
|----------------------|--|------------------|
|                      | <p>Before handling the machine, carefully read the operating manual.<br/>Observe the instructions and safety regulations for machine operation during use.</p>   | <b>P 1 H</b>     |
|                      | <p>When connecting or disconnecting, do not step between the tractor and the machine, also do not enter this space, if the tractor and the machine are not at rest and the engine is not turned off.</p>   | <b>P 2 H</b>     |
|                      | <p>Stay out of reach of the drawn-up machine.<br/>(SF4,5-6NS, SF-2,5-3,5N)</p>   | <b>P 4 H</b>     |
|                      | <p>Stay outside the reach of the tractor - agricultural machine set, if the tractor engine is in operation.</p>  | <b>P 6 H</b>     |
|                      | <p>Secure the side frames with the connecting rod prior to transport (4,5-6NS, SF4,5-11PS, SF9-12PSW).<br/>Before commencing the machine transport, secure the axle with spherical valves against unexpected drop (4,5-6PS, 8-11PS, 9-12PSW).<br/>The frame of the twin roller must be secured with the stopper for transport. (SF 2,5N-SF3,5N).</p> | <b>P 13 H</b>    |
|                      | <p>When folding the side frames, do not reach into the space of the machine folding joints.<br/>There is a danger of cutting when setting the depth of the machine.</p>  | <b>P 20 H</b>    |

|  |  |                |
|--|--|----------------|
|  | Travelling and transport on the machine structure is strictly forbidden.   | <b>P 37 H</b>  |
|  | When working and transporting the machine, maintain safe distance from the electric appliances   | <b>P 39 H</b>  |
|  | The pressure vessel is under gas and oil pressure. Execute disassembly and repairs only according to the instructions in the manual. (SF-8-11PS) | <b>P 42 H</b>  |
|  | When folding and unfolding the side frames, stay outside their reach.  | <b>P 50 H</b>  |
|  | Secure the machine against unwanted movement by positioning on its working bodies.   | <b>P 52 H</b>  |
|  | Stay outside the reach of the tractor - agricultural machine set, if the tractor engine is in operation.   | <b>P 53 H</b>  |
|  | Before commencing the machine transport, secure the axle with spherical valves against unexpected drop.  | <b>P 100 H</b> |
|  | The shown positions of the lever and the function of the hydraulic spherical valve located on the piston rod. (SF4P-11PS, 9-12PSW)               | <b>P 101 H</b> |

Fig. 1 - Location of safety labels on the machine

**SOFTER 8 PS**

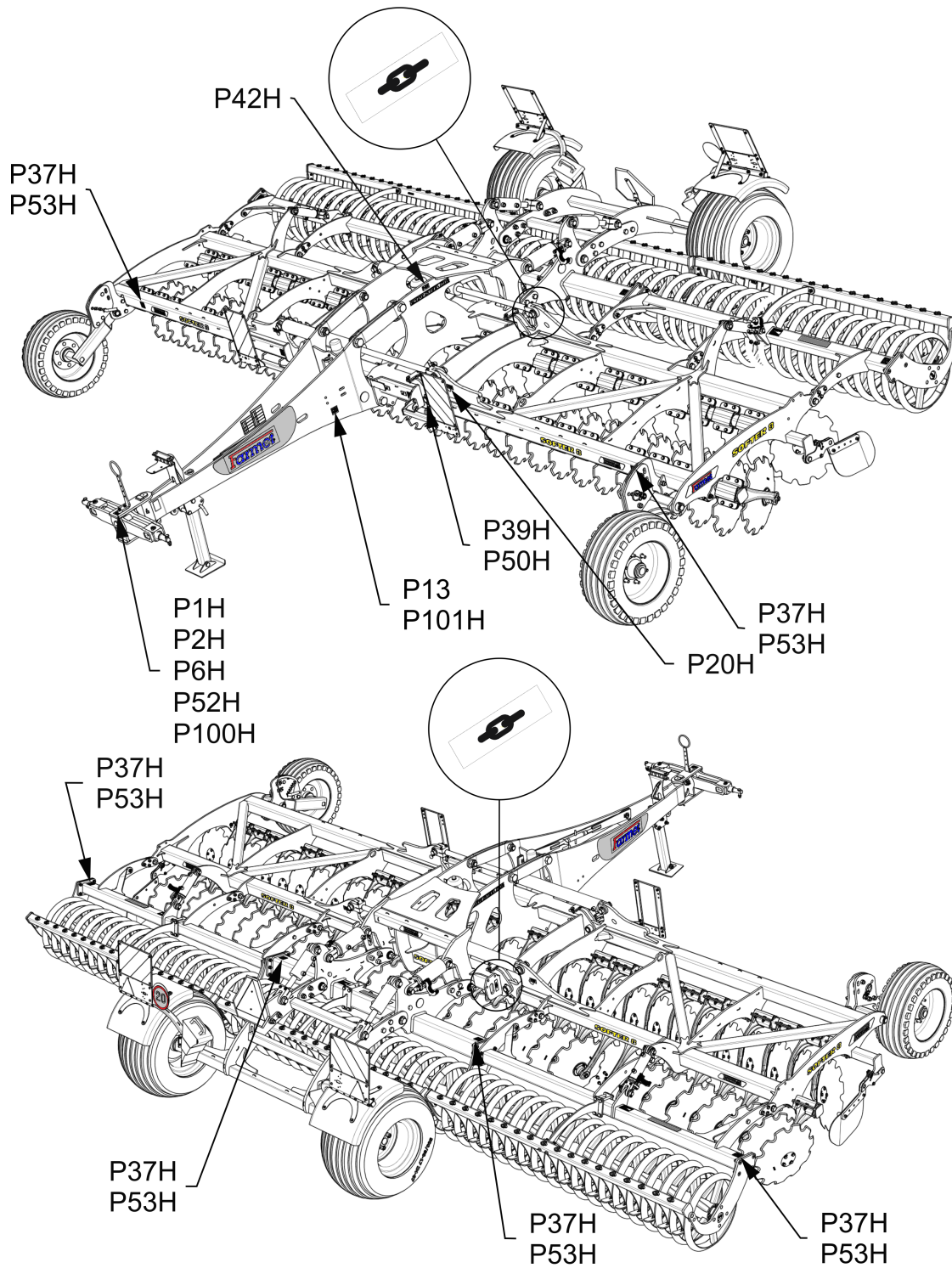

**SOFTER 11 PS**

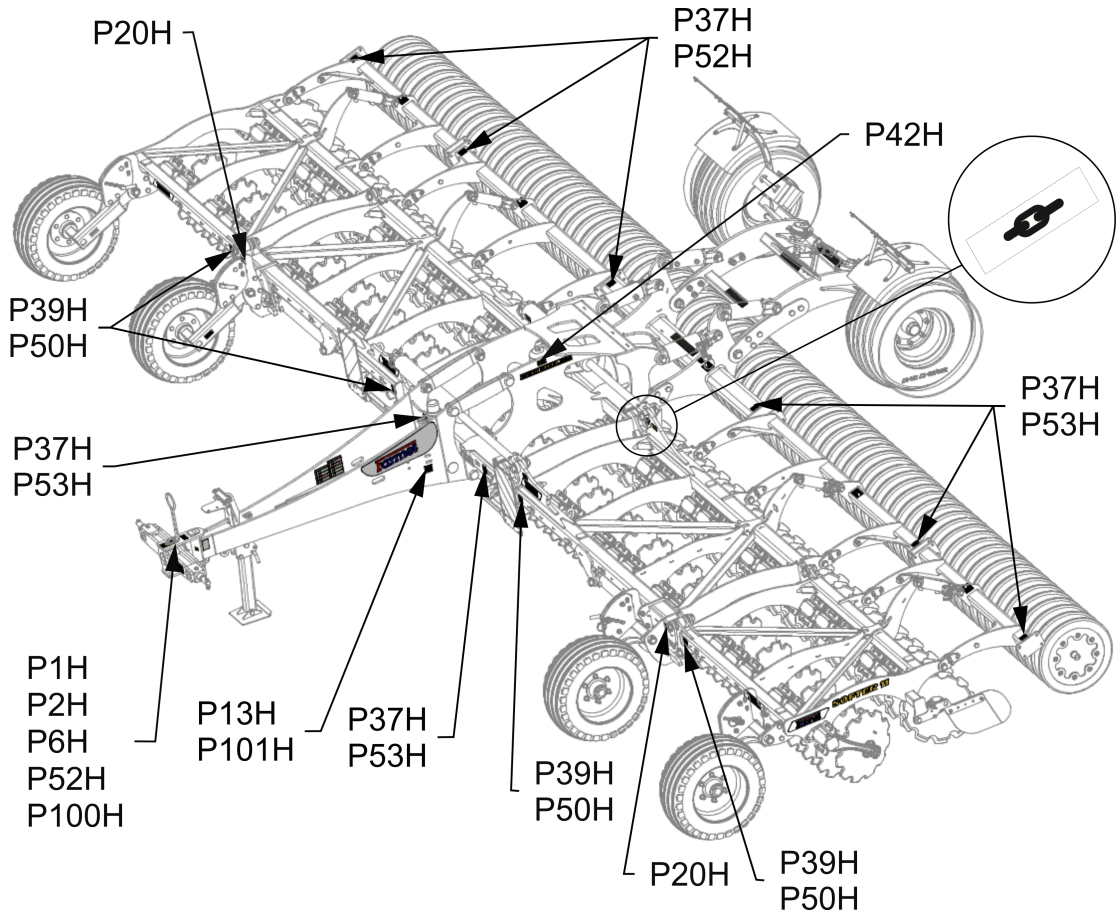



## 6 DESCRIPTION

The **SOFTER 8 PS** a **11 PS** machine is constructed as semi-carried. The basic version consists of a drawbar equipped with a three-point suspension rod, or a loop for the fixed suspension pin, a central frame with the transportation axle and two or four side frames. There are working discs in two rows on the central and side frames. There are rollers in the rear that compact the loosened soil.

### 6.1 Working parts of the machine

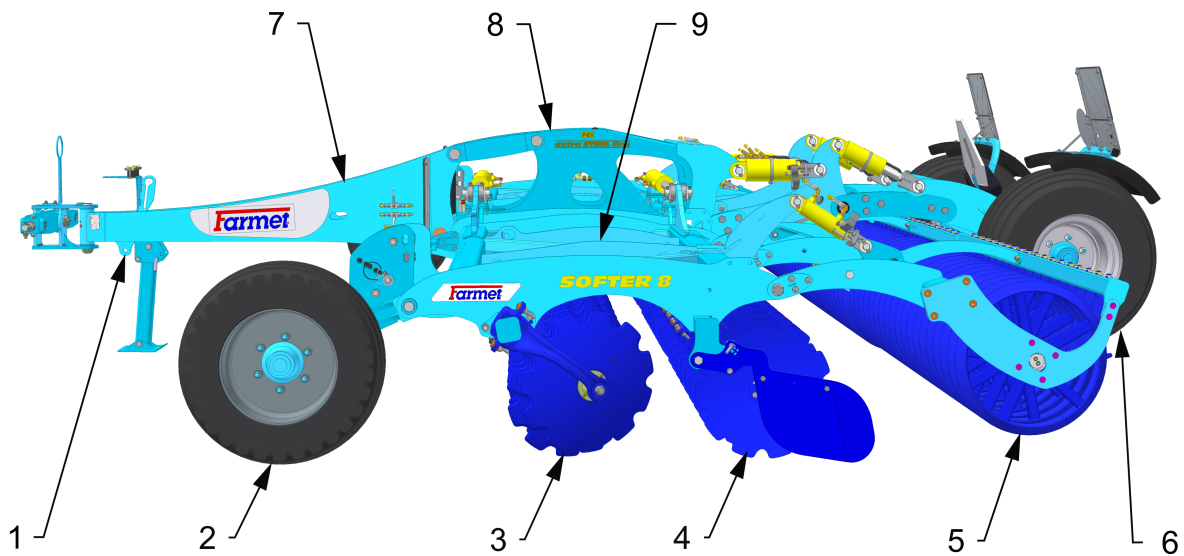

- 1 – Tractive pole with a folding leg
- 2 – Supporting wheel
- 3 – Front disc row
- 4 – Rear disc row
- 5 – Roller

- 6 – Transportation axle
- 7 – Tractive pole with a suspension bar
- 8 – Central frame
- 9 – Side frames

## 6.2 Hydraulics

Hydraulic diagram of the machine SOFTER 8PS with a drawbar in the arms of the three-point suspension

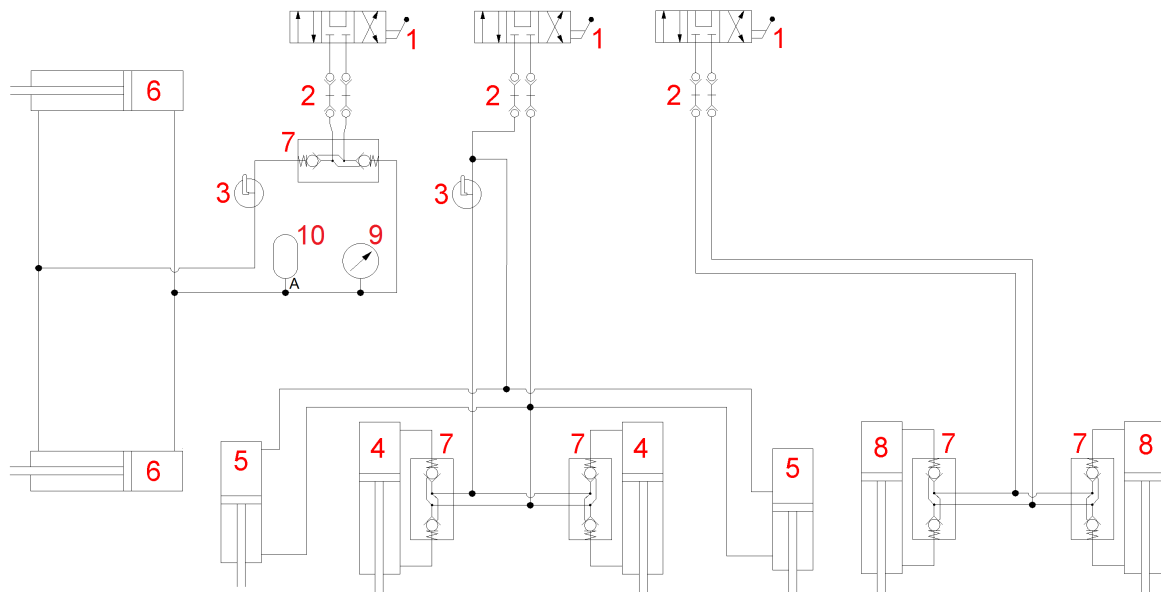

- 1 – Control distributor (tractor)
- 2 – Hydraulic coupling
- 3 – Closing cock
- 4 – Hydraulic cylinder (central roller)
- 5 – Hydraulic cylinder (side rollers)

- 6 – Hydraulic cylinder (folding side frames)
- 7 – Hydraulic closing valve
- 8 – Hydraulic cylinder (axle)
- 9 – Pressure gauge
- 10 – Pressure accumulator

Hydraulic diagram of the machine SOFTER 8 PS with a drawbar in the bottom fixed suspension

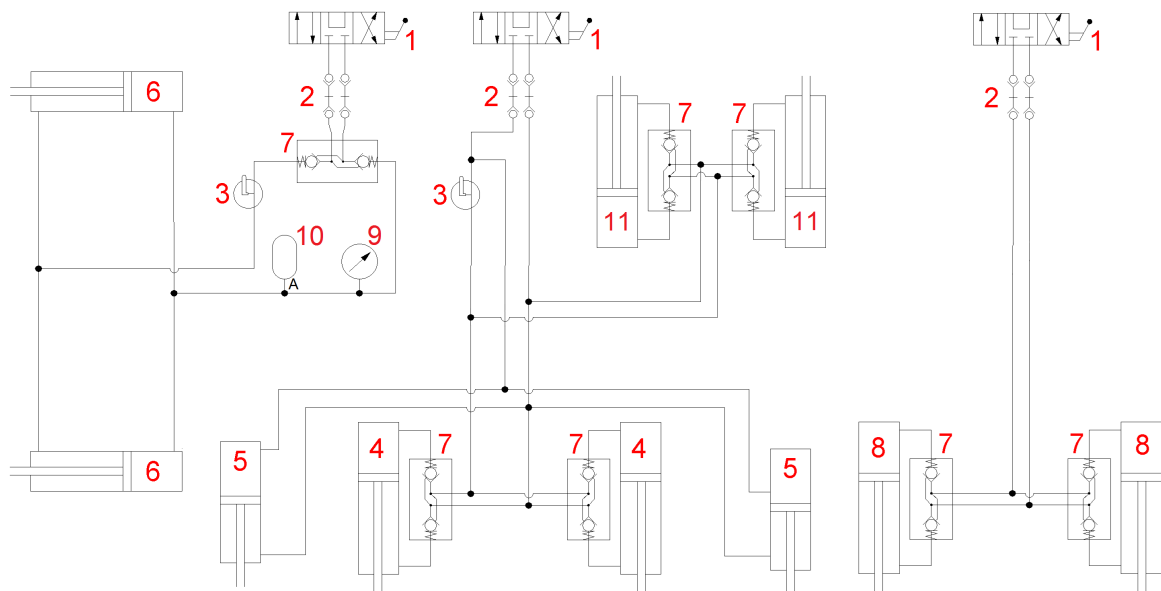

- 1 – Control distributor (tractor)
- 2 – Hydraulic coupling
- 3 – Closing cock
- 4 – Hydraulic cylinder (central roller)
- 5 – Hydraulic cylinder (side rollers)
- 6 – Hydraulic cylinder (folding side frames)

- 7 – Hydraulic closing valve
- 8 – Hydraulic cylinder (axle)
- 9 – Pressure gauge
- 10 – Pressure accumulator
- 11 – Hydraulic cylinder (drawbar)

Hydraulic diagram of the machine SOFTER 11PS with a drawbar in the arms of the three-point suspension

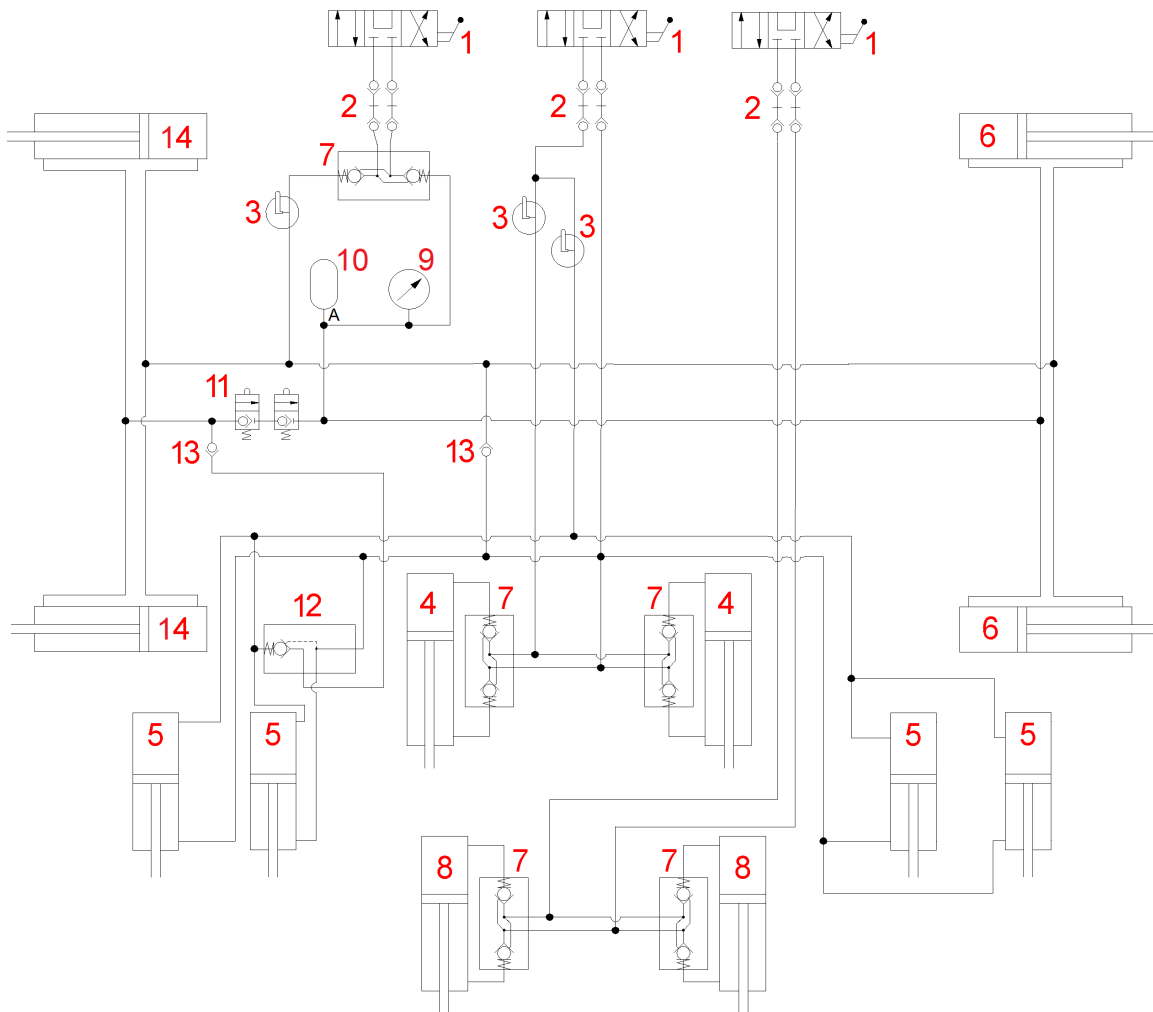

- |  |  |
|--|--|
| 1 – Control distributor (tractor)                      | 8 – Hydraulic cylinder (axle)                        |
| 2 – Hydraulic coupling                                 | 9 – Pressure gauge                                   |
| 3 – Closing cock                                       | 10 – Pressure accumulator                            |
| 4 – Hydraulic cylinder (central roller)                | 11 – Bypass valve                                    |
| 5 – Hydraulic cylinder (side rollers)                  | 12 – Hydraulic single-sided shut-off valve           |
| 6 – Hydraulic cylinder (folding side frames – central) | 13 – Return valve                                    |
| 7 – Hydraulic closing valve                            | 14 – Hydraulic cylinder (folding side frames – side) |

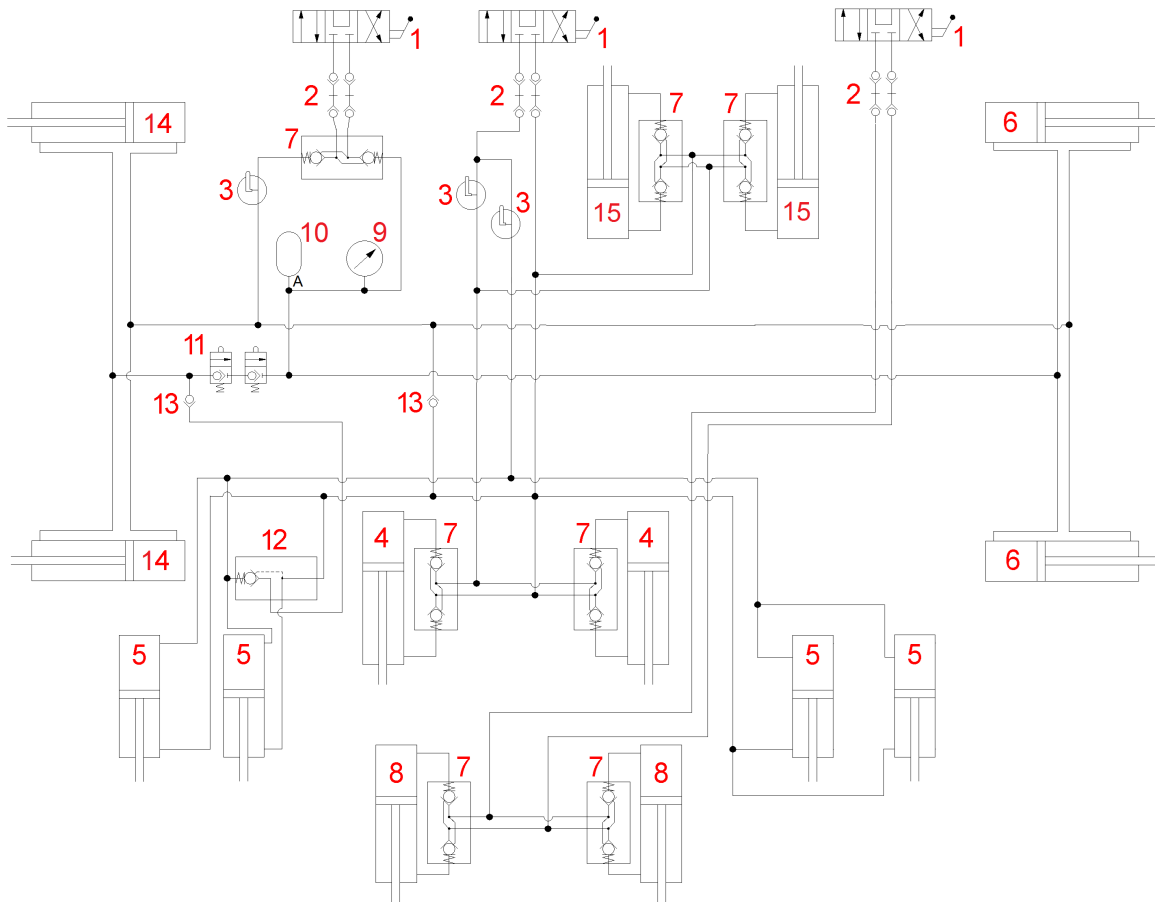
**Hydraulic diagram of the machine SOFTER11 PS with a drawbar in the bottom fixed suspension**

- |  |  |
|--|--|
| 1 – Control distributor (tractor)                      | 9 – Pressure gauge                                   |
| 2 – Hydraulic coupling                                 | 10 – Pressure accumulator                            |
| 3 – Closing cock                                       | 11 – Bypass valve                                    |
| 4 – Hydraulic cylinder (central roller)                | 12 – Hydraulic single-sided shut-off valve           |
| 5 – Hydraulic cylinder (side rollers)                  | 13 – Return valve                                    |
| 6 – Hydraulic cylinder (folding side frames – central) | 14 – Hydraulic cylinder (folding side frames – side) |
| 7 – Hydraulic closing valve                            | 15 – Hydraulic cylinder (drawbar)                    |
| 8 – Hydraulic cylinder (axle)                          |  |

**⚠ Parts of the hydraulic system of the machine, which are under pressure, are forbidden to disassemble. Hydraulic oil that penetrates the skin under high pressure causes severe injuries. In case of injury, seek a physician immediately.**

### 6.2.1 Closing (ball) valve function

- The machine SOFTER 8 PS is equipped with two closing (ball) valves on the inside the draft pole, see Fig.2
  - The machine SOFTER 11 PS is equipped with three closing (ball) valves: two on the outside and one inside the draft pole, see Fig.2
  - The external upper ball valve is used for closing the circuit for side frame unfolding (red circuit); its use is further described in Chapter 8.3.
  - The external bottom ball valve is used for closing the circuit controlling the rear roller piston-rod (including the axle) of the central frame (yellow circuit) and the drawbar piston-rods (when there is a drawbar in the bottom fixed hitch), its use is further described in Chapter 8.3.
- ⚠ • The internal ball valve is used for closing the circuit controlling the piston-rods of the side rollers (yellow circuit); this circuit must be always open in both transport and working position!!!

Fig. 2 - Closing (ball) valves

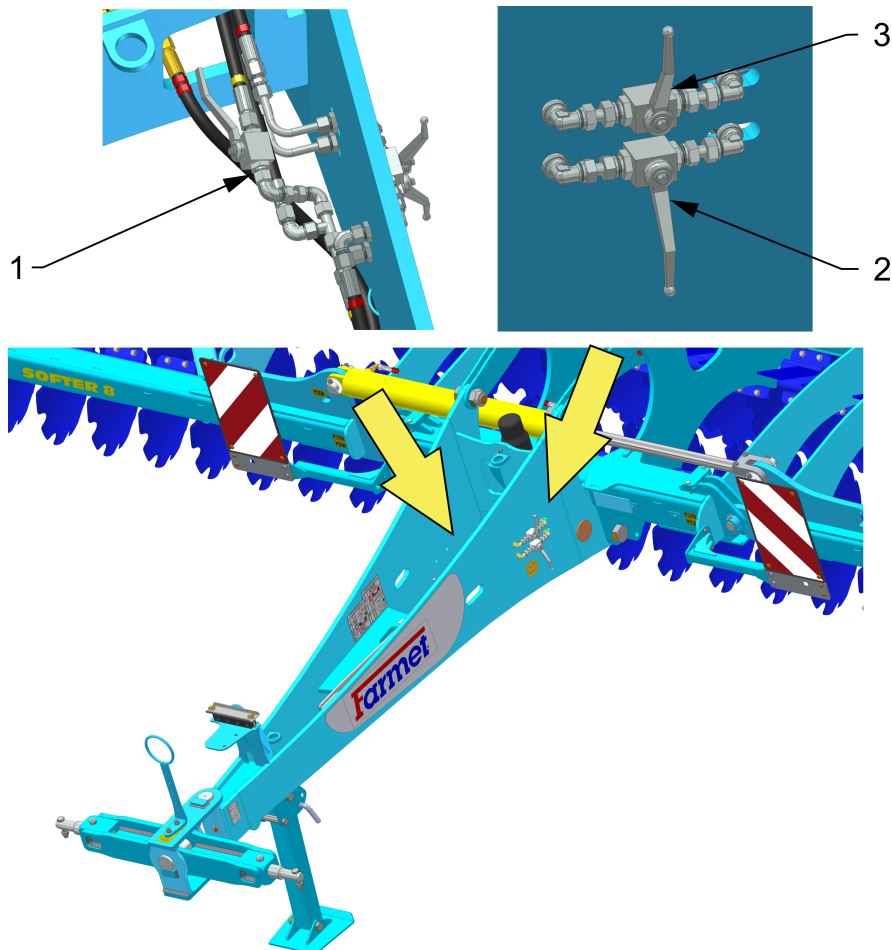

- 1 – Locking/unlocking side frame rollers (only for SOFTER 11 PS)
- 2 – Locking/unlocking the roller (axle) of the central
- 3 – Locking/unlocking side frame unfolding

**USE OF THE INTERNAL CLOSING (BALL) VALVE (SOFTER 11 PS)**

- ① After a long downtime, one or both piston-rods of the central frame roller (including the axle) may decrease. In order to draw out the piston-rods to the limit position without the collision of the side frame rollers to transport the machine safely, it is thus necessary to close this internal ball valve.

**Procedure:**

1. Close the internal ball valve – lock side rollers
2. Open the external lower ball valve – open the circuit of the central roller
3. Draw out the piston-rods of the central roller into the limit position (maximum) – circuit 
4. Close the external lower ball valve – lock the circuit of the central roller
5. Open the internal ball valve – open the circuit of the side rollers

## 7 MACHINE ASSEMBLY AT THE CUSTOMER

- The operator must perform the assembly according to the instructions of the producer, best in cooperation with the expert servicing technician determined by the producer.
-  The operator must secure a functional test of all assembled parts after the completion of the machine assembly.
- The operator must secure that the handling of the machine using lifting equipment during its assembly is in accordance with chapter „4“.

## 8 COMMISSIONING



- Before taking over the machine, test and check, whether damage occurred during transport and whether all parts contained in the bill of delivery were supplied.
- Before commissioning the machine, carefully read this operating manual, especially Chapters 1–5. Before the first use of the machine, familiarise yourselves with its controls and overall function.
- During work with the machine, observe not only the instructions of this operating manual but also generally valid regulations of work safety, health protection, fire and transport safety, and environmental protection.
- The operator must check the machine before every use (commissioning) from the standpoint of completeness, work safety, work hygiene, fire safety, transport safety, and environmental protection. A machine showing signs of damage must not be commissioned.
- Aggregation of the machine with the tractor is to be performed on a flat and hardened surface.
- When working on slopes, observe the lowest allowable slope grade of the set **TRACTOR - MACHINE**.
- Before starting the tractor motor, check whether no person or animal is in the working space of the set and push the warning sound signal.
- The operator is responsible for the safety and all damage caused by the operation of the tractor and the connected machine.
- The operator is obliged to adhere to the technical and safety regulations of the machine determined by the producer when working.
- The operator is obliged to retract the working bodies of the machine from the ground when turning at the headland.
- The operator is obliged to observe the prescribed working depths and speeds stated in the manual in. chap.1.
- The operator is obliged to lower the machine to the ground and secure the set against movement before leaving the tractor cabin.

**DECREASE OF SOIL PRESSURE TO A VALUE LOWER THAN 200 KPA (29 PSI)**

To decrease the specific pressure on soil (lower than 200 kPa / 29 Psi) at the turns on the headland, raise the machine on the pole by using the hydraulic tractor shoulders and rear rollers. Turn around when the machine is unfolded and resting on rollers.



### 8.1 Agregation to a tractor

- The machine can be connected only to a tractor, whose curb weight is identical or higher than the overall weight of the connected machine.
- The machine operator must observe all generally valid regulations of work safety, health protection, fire safety, and environmental protection.
- The operator may connect the machine exclusively to a tractor that is equipped with a rear three-point suspension (or bottom fixed suspension) and a functional undamaged hydraulic system.
- The table of requirements for the towing means for work with the machine :

|  |                             |   |  |
|--|-----------------------------|---|--|
| Requirement for the tractor engine power for the machine |                             | <b>SOFTER 8 PS</b>  | <b>200 – 300 kW (270 – 405 HP)</b>   |
|  |                             | <b>SOFTER 11 PS</b>   | <b>245 – 370 kW (330 – 495HP)</b>  |
| Requirement for tractor aggregation                      | Three-point suspension arms | Spacing of the lower suspension joints (measured at the joint axes)           | <b>1010±1,5 mm (39,76 in), (possible to set also 910±1,5 mm / 35,83 in)</b>        |
|  |                             | ∅of the hole of the lower suspension joints for the machine suspension pivots | <b>37,5 mm (1,48 in)</b>   |
|  | Fixed suspension            | Height of the bottom fixed suspension   | <b>500 – 600 mm (19,7 - 23,6 in)</b>   |
|  |                             | Mechanism of the aggregation of the bottom fixed suspension                   | <b>Pin ∅ 50 mm (1,96 in)</b>   |
|  |                             |   | <b>Pin ∅ 70 mm (2,75 in)</b>   |
|  | <b>Ball K80</b>             |   |  |
| Requirement for the tractor's hydraulic system           |                             | Side frame folding circuit  | <b>Circuit pressure 200 bar (2900Psi), 2 pcs of quick-coupler sockets ISO 12,5</b> |
|  |                             | Axle lifting circuit  | <b>Circuit pressure 200 bar (2900Psi), 2 pcs of quick-coupler sockets ISO 12,5</b> |
|  |                             | Rollers lifting circuit   | <b>Circuit pressure 200 bar (2900Psi), 2 pcs of quick-coupler sockets ISO 12,5</b> |

- Connect the machine using the TPS suspension bar to the lower arms of the rear TPS of the tractor, secure the TPS arms using pins against disconnecting, or connect the machine to the fixed bottom suspension and secure it against disconnecting.
- If the drawbar of the machine is equipped with a safety chain, attach it to the tractor.



**When connecting, no persons may stay in the space between the tractor and the machine.**

**HYDRAULIC OIL SPECIFICATIONS**

The hydraulic circuit of the machine is filled with oil at the factory:

Performance level: API GL 5; SAE 10W-30; SAE 80

Manufacturer's specification:

ALLISON C4; CATERPILLAR TO-4; VOLVO VCE WB 101; 97303 JONH DEERE 20C/20D ZF TE-ML 03E/05F/06E/06F/06K/17E/21F

PARKER DENISON HF-0/HF-1/HF-2 New HOLLAND NH 420A/410B MASSEY FERGUSON M1135/M1141/M1143/ M1145

KUBOTA UDT Fluid CASE IH MS-1204/MS-1206/ MS-1207/MS-1209 FORD M2C134D M2C86B/C CNH MAT 3525/ MAT3526

SPERRY VICKERS/EATON M2950S,I-280-S SAUER SUNDSTRAND(DANFOSS) Hydro Static Trans fluid; CASE CNH MAT 3540(CVT), Claas(CVT), AGCO CVT; ML200, Valtra G2-10(XT-60+)

## 8.2 Hydraulics connection

- Connect the hydraulics only when the hydraulic circuits of the machine and the tractor (aggregate) are in a pressure-less condition.
- The hydraulic system is under high pressure. Regularly check for leaks and immediately remove obvious damage of all lines, hoses, and pipe unions.
- When seeking and removing leaks, use only the suitable tools.
- For connecting the hydraulic system of the machine to the tractor, use the plug (on the machine) and the socket (on the tractor) of the quick-couplers of the same type. Perform the connection of the quick-couplers of the machine to the hydraulic circuits of the tractor so that the folding of the side frames (RED CIRCUIT) is on one control circuit, axle lifting (or lifting the axle and the drawbar) (YELLOW CIRCUIT) on the other control circuit, or the separate circuit of the axle (GREEN CIRCUIT) on the third control circuit.

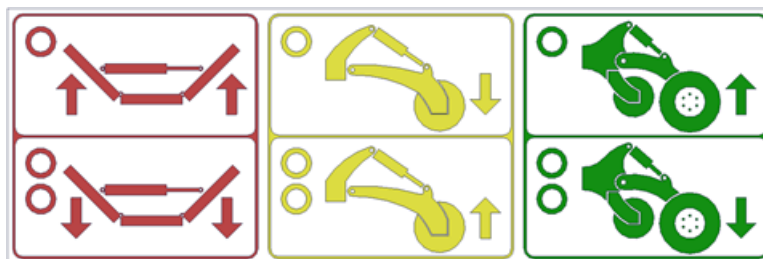

|   |  |  |
|---|--|--|
| <p><b>Red Circuit</b></p> <p>1 tape – for folding side frames into the transport position<br/>2 tapes – for unfolding side frames into the working position</p> | <p><b>Yellow Circuit</b></p> <p>1 tape – lifting the machine<br/>2 tapes – recessing the machine</p> | <p><b>Green Circuit</b></p> <p>1 tape – lowering the machine from the axle<br/>2 tapes – lifting the machine on the axle</p> |
|---|--|--|

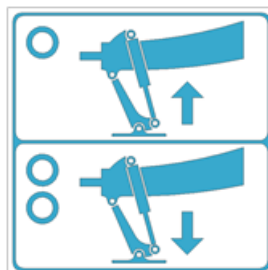

|   |
|---|
| <p><b>Blue dust caps – support leg control</b></p> <p>1 tape – retracting the leg piston-rod — the trailer is lowered<br/>2 tapes– extending the leg piston-rod — the trailer is lifted<br/>The machine with the drawbar in the bottom fixed hitch has an extra circuit for controlling the support leg (BLUE DUST CAPS).</p> |
|---|

**⚠ In order to prevent accidental or foreign person (children, passengers) caused movement of the hydraulics, the control switchboards on the tractor must be secured or blocked in the transport position.**

|  |  |                                 |
|--|--|---------------------------------|
| <p><b>⚠ PRESSURE VESSEL</b></p> <p>Never open or adjust (welding, drilling etc.) the pressure vessel (pressure accumulator). The pressure vessel is still under gas pressure even after it has been emptied. Empty the pressure vessel in case of any work on the hydraulics of the machine. The manometer must not show any pressure, or the pressure on the manometer must decrease to 0 bars. Only then it is permitted to work on the hydraulic circuit.</p> |  | <p><b>⊗</b></p> <p><b>⊙</b></p> |
|--|--|---------------------------------|

### 8.3 Folding and unfolding of the machine

- The hydraulics for the folding and unfolding must be connected to the double-action control unit.
- ⚠ • The operator must ensure that during folding and unfolding of the side frames, no person or animal is within their reach (i.e. at the place of their impact) or vicinity.
- ⚠ • Perform folding and unfolding on flat and solid surfaces or laterally to the slope with the fully open control unit.
- Execute the folding or unfolding only with a machine that is raised on the axle with the side rollers in the recessed position, i.e. their piston-rods should be drawn in.
- During folding or unfolding, check the side frames and have them continuously fold into the end position to the stoppers.
- ⚠ • Remove the adhered soil from the folding parts of the machine, as this soil can impair functionality and cause mechanical damage. Pay particular attention to removing the adhered soil in the area under the piston rods for machine folding and at the suspension points of the side frames.

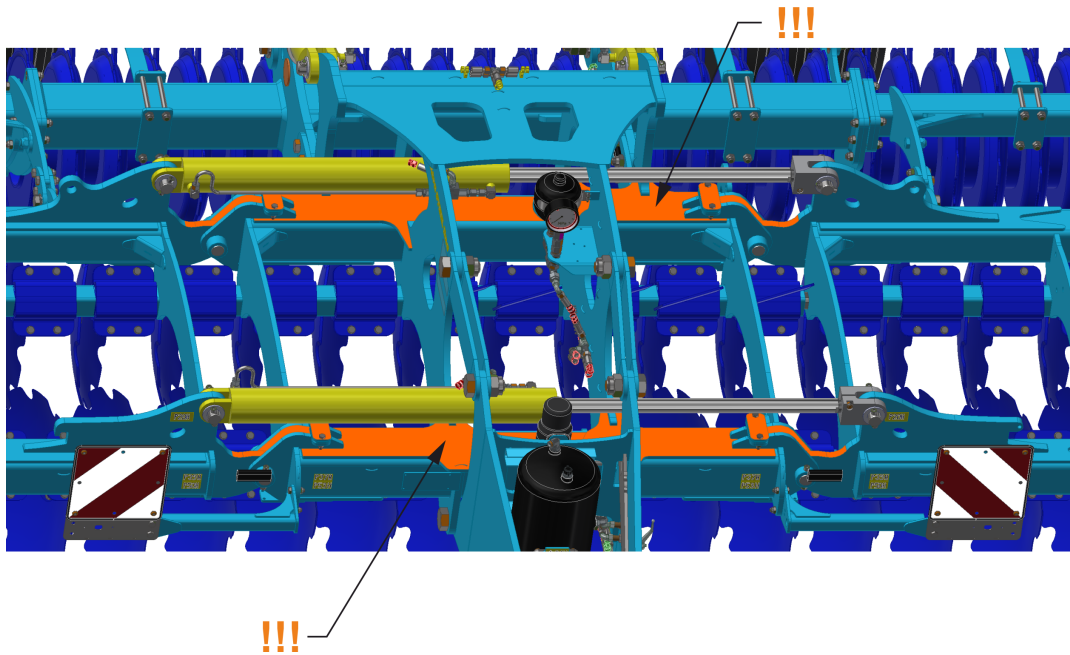

⚠ **CAUTION!!!** The machine must be lifted on the axle, when the machine is folded and unfolded. Otherwise, the rollers may get damaged.

Machine position for folding

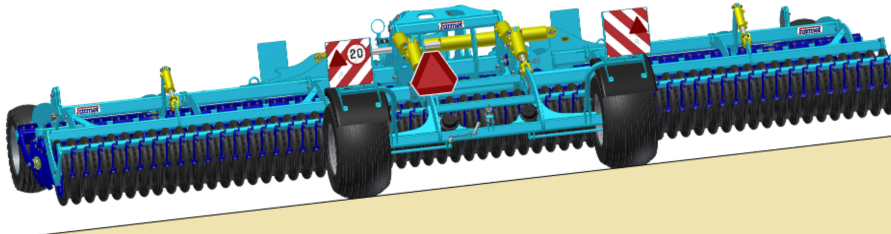
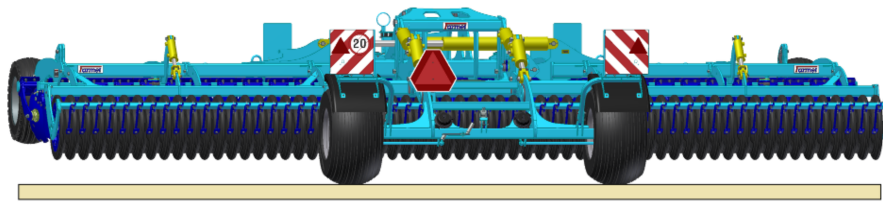

Machine position for unfolding

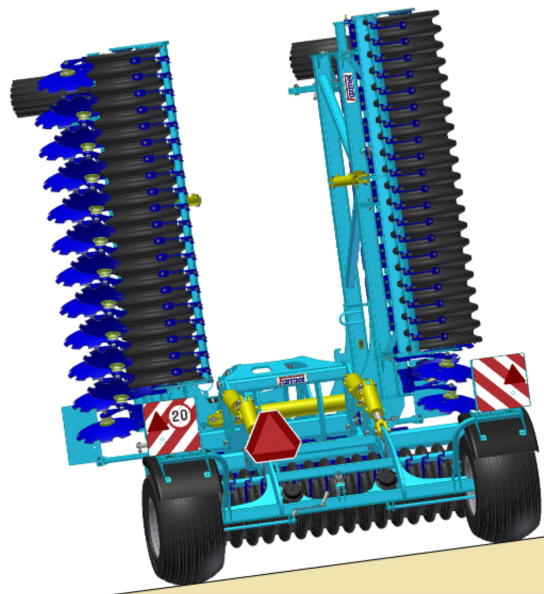
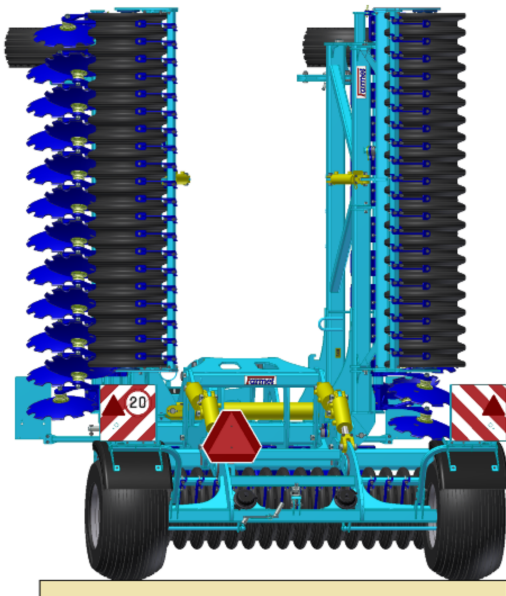

### 8.3.1 Machine unfolding procedure

| Machine unfolding procedure – work position  |  |  |  |
|--|--|--|--|
| Initial position: The machine is lifted on the axle, the side frames are secured with the drawbar and belt, both ball valves outside are closed. |  |  |  |
| 1  |  |  | Remove the drawbar securing, place them on the pole. Open both ball valves located on the drawbar.   |
|  |  |  | Unfold the machine using the red circuit.  |
| 2  |  |  | Draw out the piston-rods of the side rollers using the yellow circuit into the marginal position, i. e. maximum release.   |
|  |  |  | Draw in the piston-rods of the axle using the green circuit into the marginal position, i. e. maximum insertion. The machine will rest on all rollers equally.   |
|  |  |  | Place the relevant number of spacer rings on the roller piston-rods and set the tracing wheel (according to the required recess of the machine). If the machine is equipped with a drawbar for fixed suspension, set the distance washers also on the drawbar piston rods. Draw in the piston-rods of all rollers (drawbar) using the yellow circuit. The machine is ready for work. |
| <p>100 bar</p>   |  | <b>SETTING THE DOWN PRESSURE OF SIDE FRAMES</b> <ul style="list-style-type: none"> <li>When the machine has been unfolded, the down pressure of the side frames must be adjusted to ensure optimal terrain tracing.</li> <li>Set the value of 100 bar (1450 Psi) on the pressure gauge using the circuit for unfolding.</li> </ul> |  |

- The safety drawbar must be disassembled before unfolding the machine.
- When the machine folded into the transport position, the side frames must be secured with the drawbar against spontaneous unfolding.

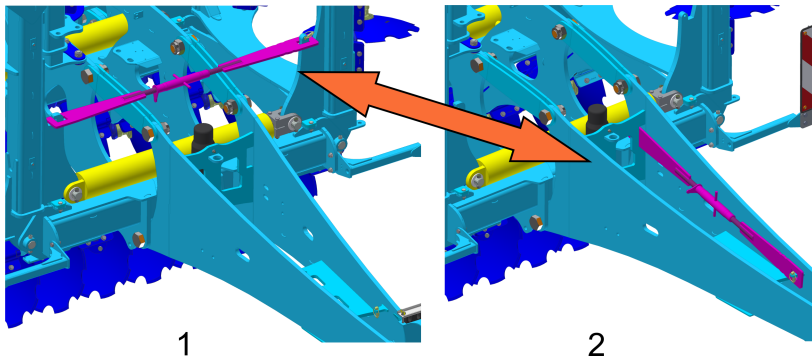

1 – Transport position  
2 – Work position

### 8.3.2 Machine Folding Procedure

| Machine Folding Procedure – Transport Position   |  |  |  |   |
|--|--|--|--|---|
| Initial position: The machine is unfolded and recessed, both ball valves outside are opened. |  |  |  |   |
| 1  |  |  |  | Lift the machine on the rollers (or rollers and drawbar), i.e. draw out the piston-rods of rollers (drawbar) using the yellow circuit into the marginal position, i. e. maximum release.  |
|  |  |  |  | Lift the machine on the axle, i.e. draw out the piston-rods of the axle using the green circuits into the marginal position, i. e. maximum release. For SOFTER 11 PS, provide a right deflector for transport.*   |
| 2  |  |  |  | Close the ball valve of the circuit of the central roller – axle (lower) and fold the machine using the red circuit.  |
| 3  |  |  |  | Close the ball valve of the folding circuit (upper) and draw in the piston-rods of the side rollers using the yellow circuit into the marginal position, i.e. maximum retraction. Note: As for SOFTER 11 PS, the piston-rods of the side rollers are automatically drawn in when the machine is folded. |
|  |  |  |  | Secure the side frames with the securing drawbar and belt. The machine is ready for transport.  |

\* Securing the right deflector for transport

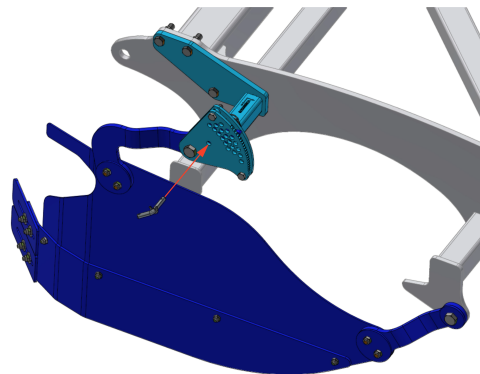



ⓘ Warning!!! The machine must only be transported by the axle, not rollers.

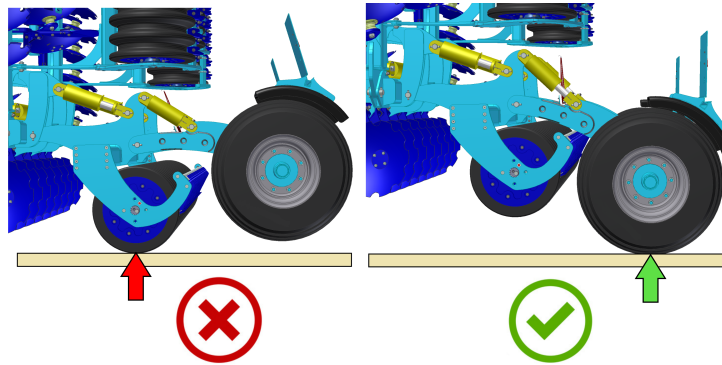

## 9 MACHINE TRANSPORT ON ROADS

### Transport position



- Connect the machine by suspending on the tractor using the two-point suspension equipment (TPS 3), or the fixed bottom suspension using a pin or a ball.
- Bring the machine into the transport position (according to chapter 8.3.2.)
- The machine must be equipped with removable shields with marking of contours, functional lighting, and the board of the rear marking for slow vehicles (according to ECE No. 69).
- The lighting must be activated during travelling on roads.
- The tractor must be equipped with a special light device of an orange colour, which must be activated during travelling on roads.
- The maximum transport speed during travelling on roads is **30 km/hod (18,6 mph)**.



### Ban of transport with decreased visibility!

- The operator is obliged to pay increased attention during transport on roads, due to the transport dimensions of the machine.
- The operator must observe the valid regulations for transport on roads (laws, decrees) after connecting the machine to the tractor, for reason of a change of the axle load. The driving properties of the set also change depending on the terrain nature, adapt the manner of driving to these conditions.
- Only machines with a valid technical certificate issued in accordance with the valid regulation on the approval of technical qualification and operation on public communications as amended may be transported on public communications. Machines without a valid technical certificate may only be transported on public communications when carried by a towed trailer or other approved means of transport in accordance with the valid regulation.
- The operator is obliged to secure sufficient outlook during reversing from his position of the tractor driver. In case of insufficient outlook, the operator is obliged to call a competent and informed person.
- The operator must fold the side frames for transport and secure them against unwanted unfolding by disconnecting the hydraulic circuit of the machine and the tractor.
- The operator must secure the arms of the rear TPS of the tractor in the transport position during road transport, i.e. prevent unexpected arm drop using the hydraulic arm control lever. At the same time, the arms of the rear TPS of the tractor must be secured against side swinging.
- During machine transport on roads, the operator must observe the valid laws and decrees that deal with this topic and which specify the relationships of the tractor axle load depending on transport speed.
- Clean the entire machine from any accumulated soil before the transportation on the road.

### Checking the nuts on the transport axle

- Use the plastic arrow “Check Point” to check for loose nuts. It promptly shows the condition of the nuts, whether they are loose or not.
- Always check the Check Points before driving.
- When the arrows are not facing one another, the nuts have to be tightened to the required torque and the Check Point arrows have to point against one another as shown in the green picture.

#### Torque for the axle nuts:

- M18x1,5 - 265 Nm
- M20x1,5 - 343 Nm
- M22x1,5 - 440 Nm

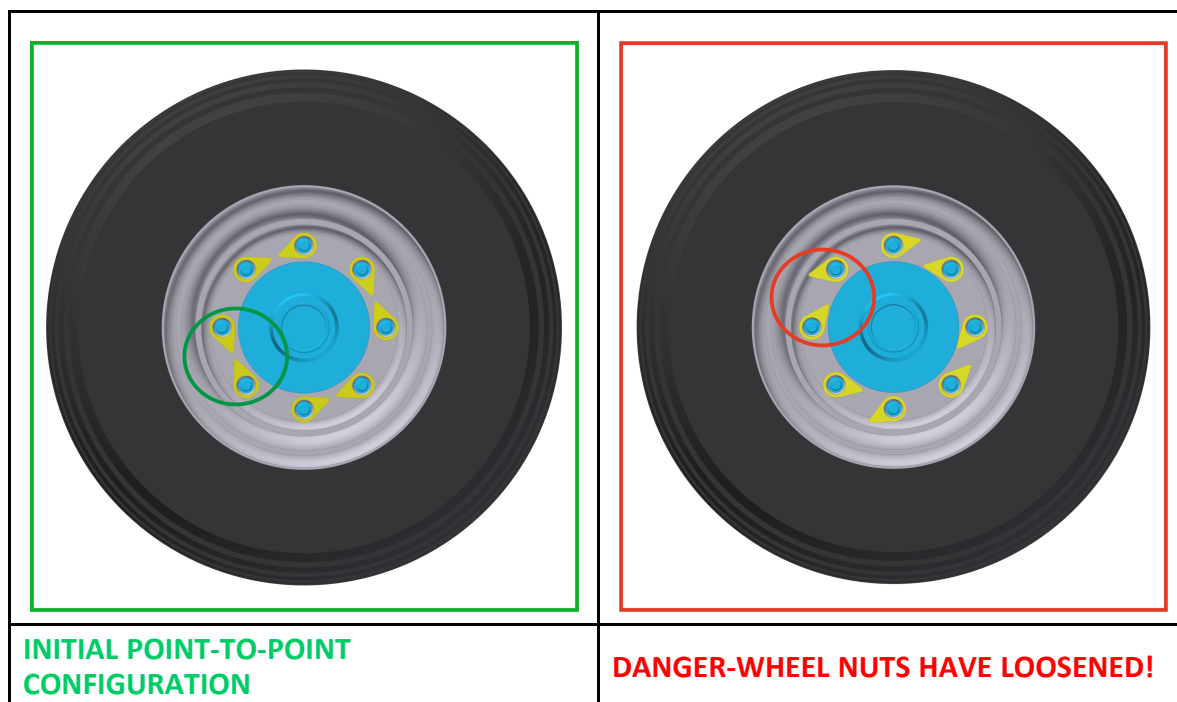

## 9.1 Sharp machine projections



- The machine contains sharp structural projections
- **It is prohibited to operate and transport the machine on roads when visibility is reduced!!** - Persons or objects, or other road traffic participants could get caught.
- **The machine operator must be extra cautious when driving on roads and consider the width of the machine and safe distance from persons, vehicles and objects, or other road traffic participants!!**

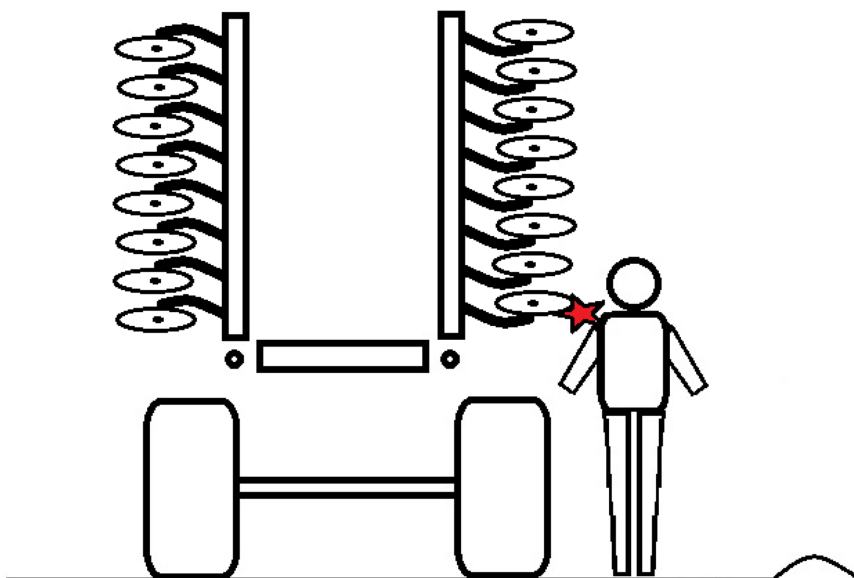

## 10 MACHINE ADJUSTMENT

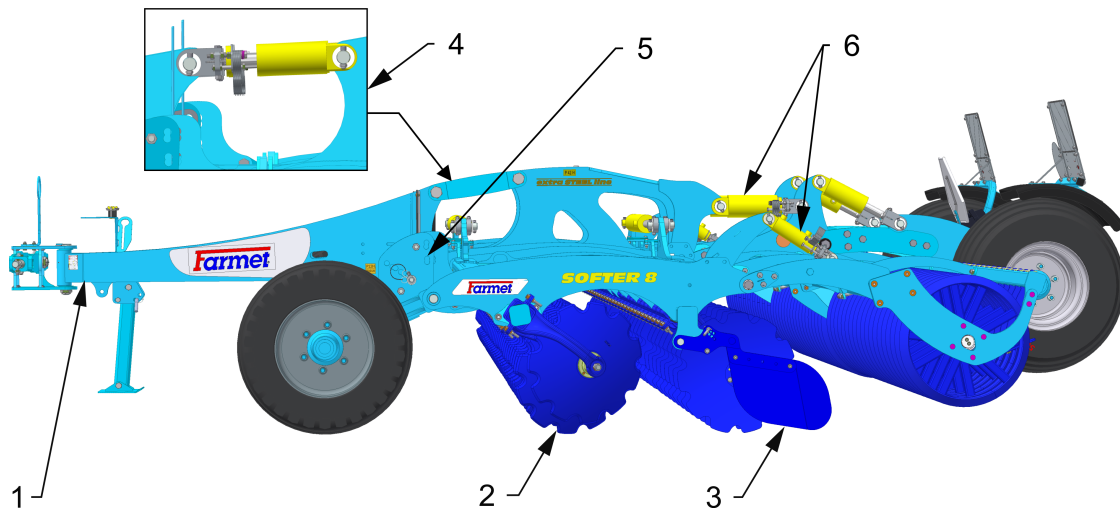

- 1 – Tractive pole – Setting of machine longitudinal plane
- 2 – Edge discs – Connection of drives
- 3 – Side deflectors – Soil orientation
- 4 – Fixed suspension version, Depth setting
- 5 – Tracing wheels – side frame control
- 6 – Piston-rods of rollers - Spots for setting the working depths

### 10.1 Adjusting the working depth of the machine

- Setting the depth of soil processing is executed when the machine is lifted on the rollers by adding or removing distance washers on the piston rods of the rollers.
- When changing the depth of soil processing, the pins of the tracing wheels also have to be adjusted in the relevant positions.

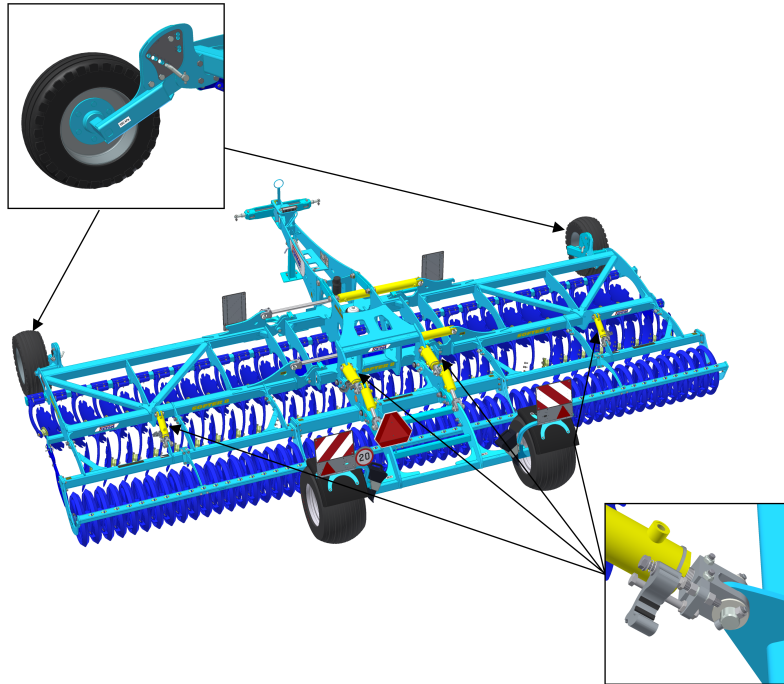

Tab.1 – Setting of working depth in mm/in

- **The same number of washers must be set on all piston rods!!!**
- The change ratio between the thickness of the crossbars and the working depth is 1:3.
- Example: Adding or removing a washer with the thickness of 3mm (0.12in) changes the working depth of the machine by 8-9mm (0.32-0.35in).
- Tab.1 includes the individual working positions and the number of washers needed to achieve the required depth of the machine.
- The position of the tracing wheel for the individual depths is provided in Tab. 1 in the first column. The number of the position in the table corresponds with the number of the opening for the pin on the tracing wheel arm.
- Specified working depths at individual positions are only for information. They may vary according to particular soil conditions. Required number of distance washers may be added/removed as needed.

1 – The position of the tracing wheel  
 2 – Number of washers  
 3 – Working depth  
 X – 5 x adjustment shims (Adjustment shims are used to achieve a minimum working depth of 3,5 cm (1.38 in) in cases where the rear rollers sink deeper into the soil.)

|    |  |  |           |
|----|--|--|-----------|
|    |  |  | 0 / 0     |
|    |  |  | 7 / 0.3   |
|    |  |  | 14 / 0.6  |
| 1  |  |  | 21 / 0.8  |
|    |  |  | 28 / 1.1  |
|    |  |  | 35 / 1.4  |
|    |  |  | 42 / 1.7  |
| 2  |  |  | 49 / 1.9  |
| 3  |  |  | 56 / 2.2  |
| 4  |  |  | 64 / 2.5  |
| 5  |  |  | 72 / 2.8  |
| 6  |  |  | 80 / 3.2  |
| 7  |  |  | 88 / 3.5  |
| 8  |  |  | 96 / 3.8  |
| 9  |  |  | 104 / 4.1 |
| 10 |  |  | 112 / 4.4 |
| 11 |  |  | 120 / 4.7 |

[ mm / in ]

m24170

1      2      3

## 10.2 Drawbar for the bottom fixed hitch

- If the machine is equipped with a drawbar for the bottom fixed suspension, it is required to set the working depth using the spacing washers also on the piston rods of the drawbar as shown below.

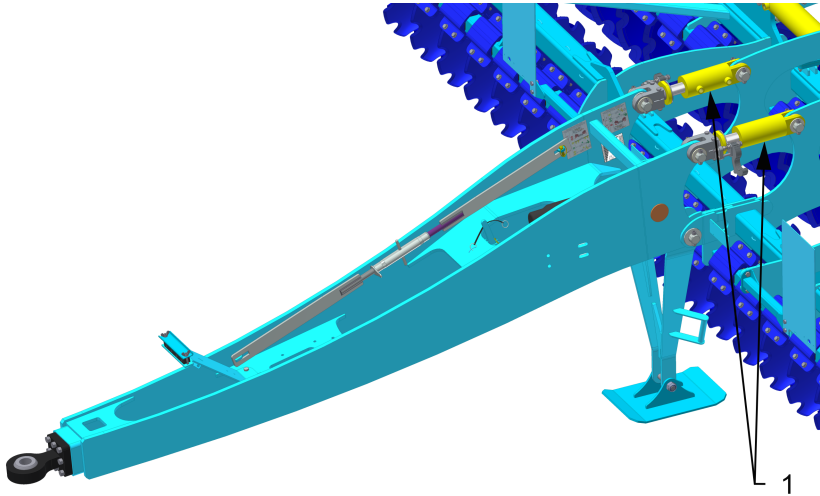

1 – Depth adjustment on the drawbar

- When aggregating the machine to the tractor with a bottom hitch at the height of 600 mm (24 in) from the ground, use the same number of washers on the drawbar piston-rods as on the rear rollers; when the hitch is lower, the height has to be corrected using additional washers according to tab.2.

- 1 – Hitch height  $h = 600 \text{ mm} / 24 \text{ in}$   
Washers same as on rollers
- 2 – Hitch height  $h = 550 \text{ mm} / 22 \text{ in}$   
Washers same as on rollers + 6 ks
- 3 – Hitch height  $h = 500 \text{ mm} / 20 \text{ in}$   
Washers same as on rollers +12

Tab. 2 – Setting the working depth on the drawbar

|    |                  | h [mm/in] |        |        |           |
|----|------------------|-----------|--------|--------|-----------|
|    |                  | 600/24    | 550/22 | 500/20 |           |
| 1  | [Washer pattern] |           |        |        | 32 / 1.3  |
| 2  | [Washer pattern] |           | +6     | +12    | 40 / 1.6  |
| 3  | [Washer pattern] |           |        |        | 48 / 1.9  |
| 4  | [Washer pattern] |           |        |        | 56 / 2.2  |
| 5  | [Washer pattern] |           |        |        | 64 / 2.5  |
| 6  | [Washer pattern] |           |        |        | 72 / 2.8  |
| 7  | [Washer pattern] |           |        |        | 80 / 3.2  |
| 8  | [Washer pattern] |           |        |        | 88 / 3.5  |
| 9  | [Washer pattern] |           |        |        | 96 / 3.8  |
| 10 | [Washer pattern] |           |        |        | 104 / 4.1 |
| 11 | [Washer pattern] |           |        |        | 112 / 4.4 |
|    |                  |           |        |        | 120 / 4.7 |

### 10.3 Adjusting the longitudinal plane of the machine

- With the use of the TBZ shoulders of the tractor, or the spacing washers on the piston rods of the drawbar, adjust the machine so that the front and rear row discs work in the same depth.

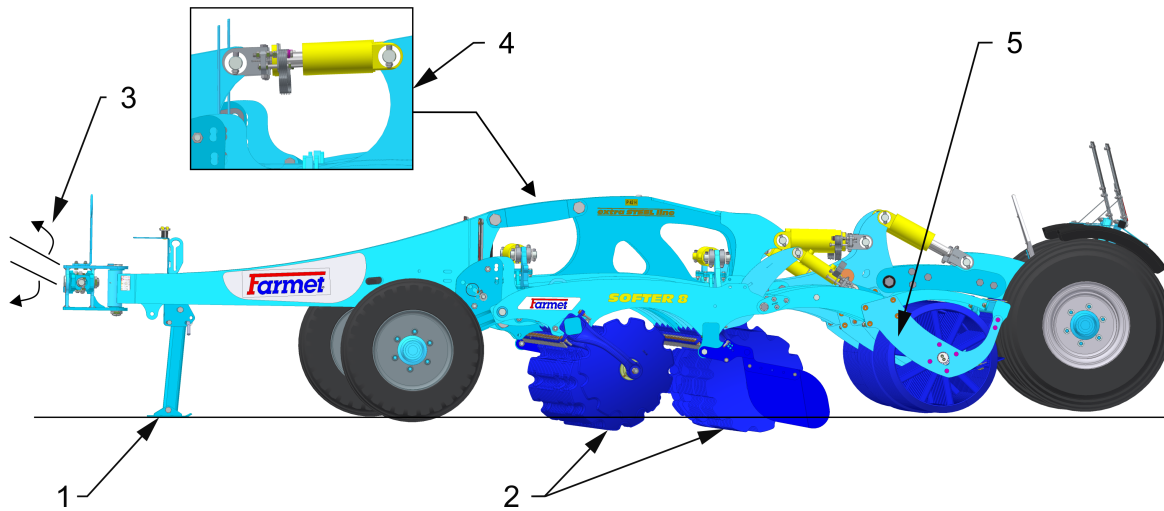

- 1 – Soil
- 2 – Setting the same depth for front and rear disc rows
- 3 – TBZ shoulders of the tractor
- 4 – Fixed suspension version, Depth setting
- 5 – Setting the depth by rear rollers

The machine features high stability during operation. However turning of machine to one side may occur with fault adjusted longitudinal plane (particularly in heavy soils). This is removed by modification of tractor arm height as follows, or by adding or removing spacing washers on the drawbar piston rods:

- When the machine turns to the right-hand side, lift the machine in arms, or remove washers on the drawbar piston-rods

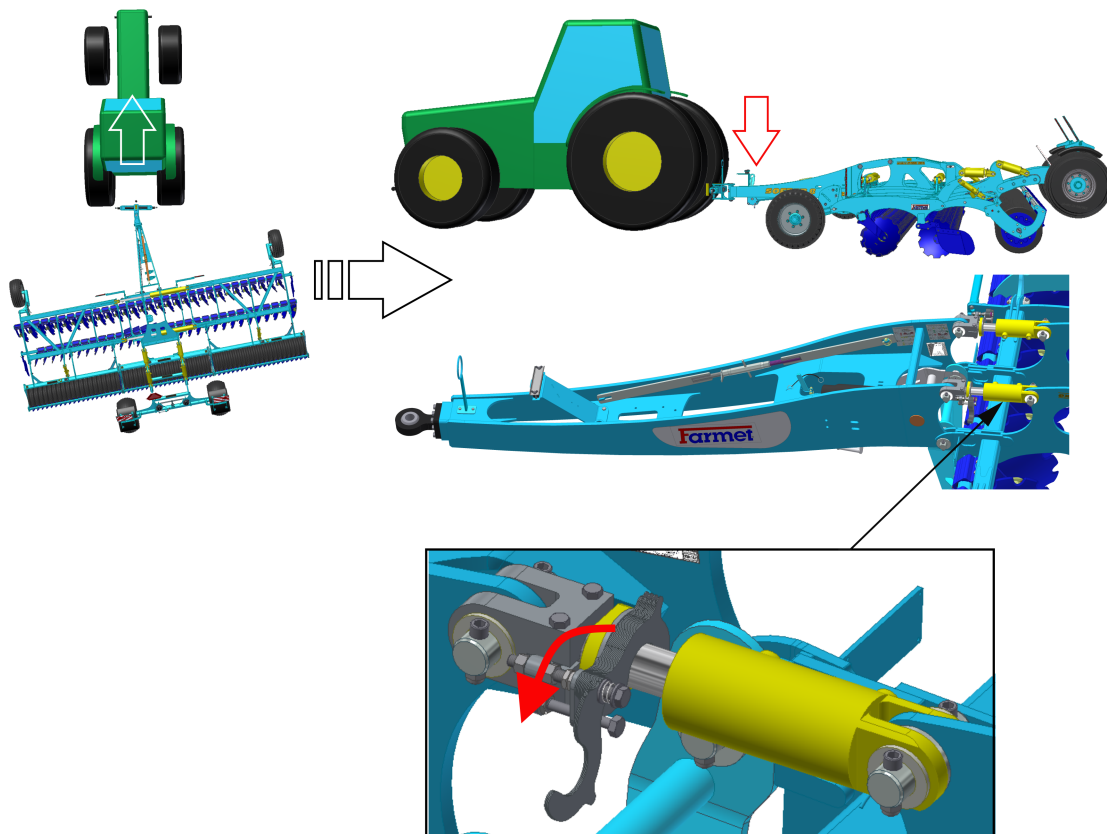



- When the machine turns to the left-hand side, lower the machine in arms, or add washers on the drawbar piston-rods

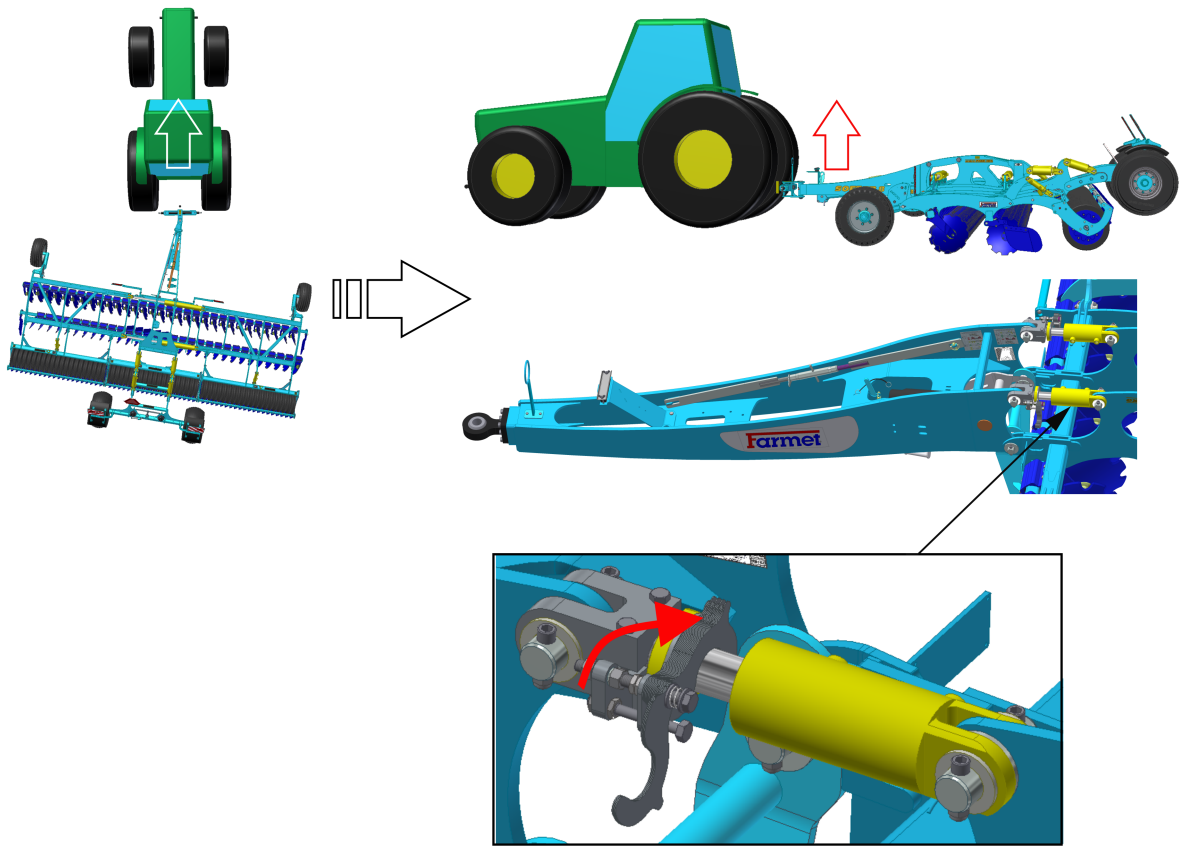

### 10.4 Setting side deflectors and edge discs

- According to the type and quantity of plant residues, it is necessary to set the side deflectors.

Options for side deflector settings

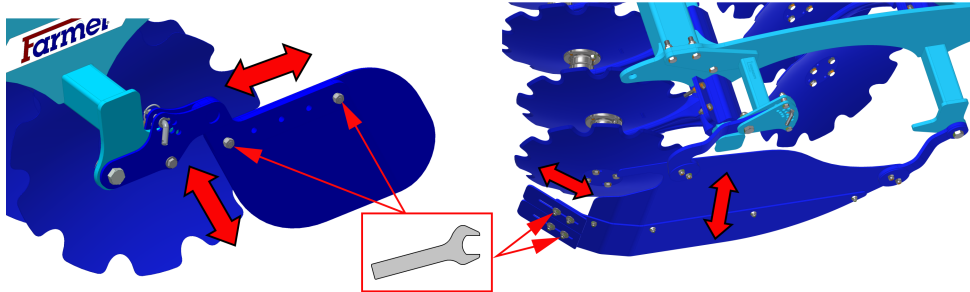

- The position of the edge discs is adjustable and they allow different recess against other discs. The adjustment is executed so that the working depth of the edge discs is lower (approx  $\frac{1}{2}$  -  $\frac{1}{4}$  of the depth of the other discs) so that no unevenness is created on the land.

Options for edge disc settings

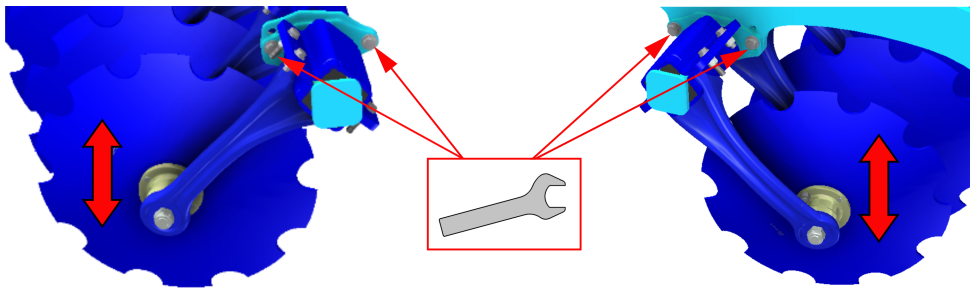

### 10.5 Machine travelling direction at work

Change the direction of work with the machine by 15-30° to the previous seeding/harvest operation. That will help you achieve the best work results with the machine: a high crop residue throughput, mixing crop residue in and the levelling effect (levelling the tracks from previous operations)

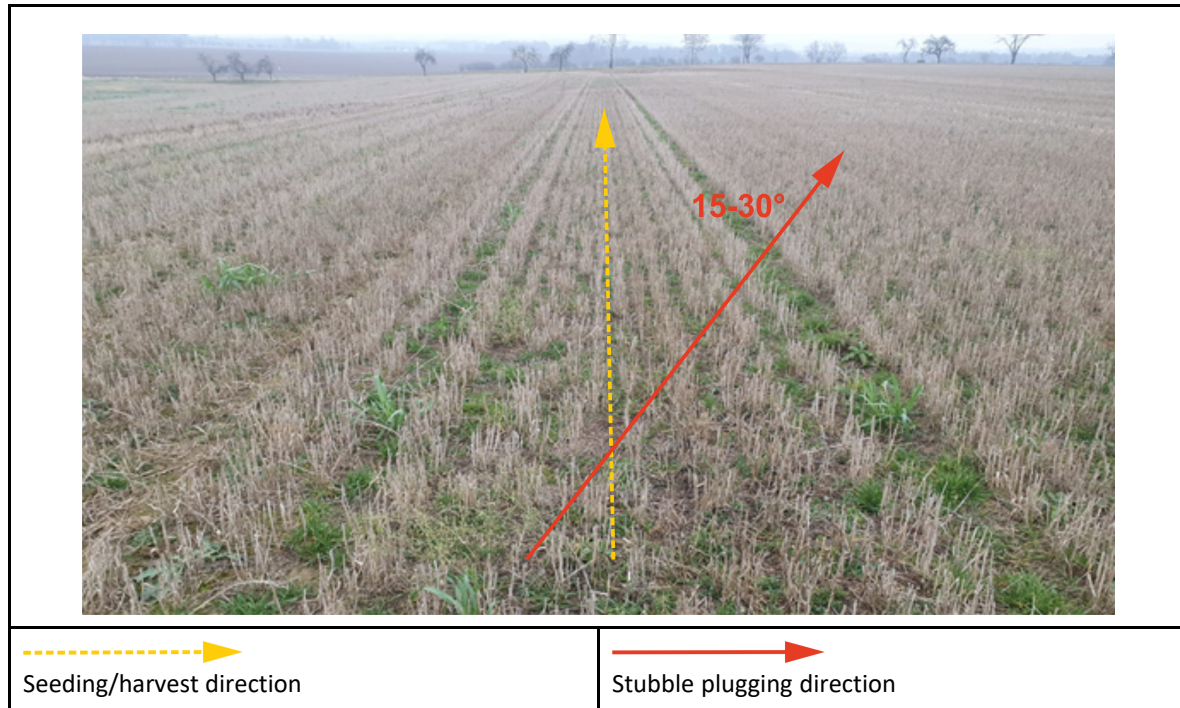

When the machine works in the same direction as in the previous operations (seeding/harvest), it can get clogged, which reduces the quality of work and the levelling effect of the machine.



## 11 MACHINE MAINTENANCE AND REPAIRS



**Observe the safety instructions for treatment and maintenance.**

- If it is necessary to weld during the repair and have the machine connected to the tractor, it must have disconnected supply cables from the alternator and the accumulator.
- Check the tightening of all screw and other assembly connections at the machine before every use of the machine, furthermore continuously as needed.
- Continuously check the wear of the working bodies of the machine, possibly replace these worn working bodies with new ones.
- Adjustment, cleaning, and lubrication of the machine may only be performed with the machine at rest (i.e. the machine is standing and not working).
- When working on a lifted machine, use suitable support equipment supported at marked points or at points suitable for that.
- During adjustment, cleaning, maintenance, and repair of the machine, you must secure those parts of the machine that could endanger the operator by falling or another movement.
- For catching the machine during handling using lifting equipment, use only the places marked with self-adhesive labels with the chain sign "—Ⓞ—".
- Upon a failure or damage of the machine, immediately turn off the tractor's engine and secure against restarting, secure the machine against movement — only then you can remove the failure
- During repairs of the machine, use exclusively the genuine spare parts, suitable tools and protective equipment.
- Regularly check the prescribed pressure in the machine tyres and the condition of the tyres. Perform possible repairs of the tyres in an expert workshop.
- Keep the machine clean.

### 11.1 Maintenance plan

| <b>MAINTENANCE PLAN</b>   |   |             |               |              |                   |
|---|---|-------------|---------------|--------------|-------------------|
| Perform the planned maintenance according to the instructions:  |   |             |               |              |                   |
| Maintenance Task  | Daily (season)  | Once a week | Before season | After season | Time interval     |
| Machine in general  |   |             |               |              |                   |
| <ul style="list-style-type: none"> <li>• Visual inspection of the machine</li> <li>• Checking for any undesirable sounds, vibrations and excessive wear</li> </ul>  | <b>X</b>  |             |               |              |                   |
| <ul style="list-style-type: none"> <li>• Checking crucial nodes: pins, bearings, rollers, working parts</li> </ul>  | <b>X</b>  |             | <b>X</b>      | <b>X</b>     |                   |
| <ul style="list-style-type: none"> <li>• Machine cleaning</li> <li>• Storing the machine under roof, if possible</li> <li>• Recording the mileage of the machine/ season (ha)</li> </ul>  |   | <b>X</b>    |               | <b>X</b>     |                   |
| <ul style="list-style-type: none"> <li>• Comprehensive inspection</li> <li>• Checking the frame</li> </ul>  | <b>X</b>  |             |               | <b>X</b>     |                   |
|   | Do not use a high-pressure cleaner or direct stream of water to clean the hydraulic rollers, bearings, electric and electronic parts. The seals and bearings are not waterproof at high pressure. |             |               |              |                   |
| Hydraulic system  |   |             |               |              |                   |
| Checking the function, tightness, mounting and worn spots of all hydraulic parts and hoses  |   | <b>X</b>    | <b>X</b>      |              |                   |
| <b>Hydraulic hoses – replacement:</b> <ul style="list-style-type: none"> <li>• Damaged external casing of the hose (mechanically or blistered)</li> <li>• Fluid seepage (especially the end piece)</li> <li>• Bumps or blisters on the hose</li> <li>• Deformed or corroded end piece</li> <li>• Loose end piece – the hose spins</li> </ul>  | <b>X</b>  |             |               | <b>X</b>     |                   |
| <b>Hydraulic hoses - replacement:</b> <ul style="list-style-type: none"> <li>• Expired service life of the hose</li> </ul> <div style="display: flex; justify-content: space-around; margin-top: 10px;">   </div> |   |             |               |              | 6<br><b>years</b> |
| <p><b>!!!PREVENTION means removing the problem according to the plan, outside the season, without stress and comfortably before a secondary problem, an accident or a health hazard arises.</b></p>   |   |             |               |              |                   |

| <b>MAINTENANCE PLAN</b>   |                |             |               |              |               |
|---|----------------|-------------|---------------|--------------|---------------|
| <b>Perform the planned maintenance according to the instructions:</b>   |                |             |               |              |               |
| Maintenance Task  | Daily (season) | Once a week | Before season | After season | Time interval |
| <b>Bolt connections</b>   |                |             |               |              |               |
| <b>Visual</b> inspection of bolt and hydraulic joints, tighten any loose joints using a corresponding torque (see the torque chart)   | <b>X</b>       |             |               | <b>X</b>     |               |
| <b>Towing lug</b> – check, tighten if needed<br>M 16 – 10.9. – 300 Nm<br>M 20 – 10.9. – 560 Nm   |                | <b>X</b>    | <b>X</b>      |              |               |
| <b>Wheels – tighten all wheel nuts</b> <ul style="list-style-type: none"> <li>First time: after 10 hours of operation</li> <li>Wheel replacement : after 10 hours of operation</li> </ul> M 18 x 1,5 – 300 Nm<br>M 20 x 1,5 – 400 Nm<br>M 22 x 1,5 – 500 Nm |                | <b>X</b>    | <b>X</b>      |              |               |
| <b>Brake system</b>   |                |             |               |              |               |
| <b>Brake line and hoses</b> – check the function, tightness, mounting and clamping, or breaking   | <b>X</b>       |             | <b>X</b>      | <b>X</b>     |               |
| <b>Brake components</b> – check the function, tightness, mounting   | <b>X</b>       |             | <b>X</b>      | <b>X</b>     |               |
| <b>Air nozzle</b> – drain using the draining valve  |                | <b>X</b>    |               | <b>X</b>     |               |
| <b>Draining valve</b> – check the function, clean and replace sealing   |                |             | <b>X</b>      | <b>X</b>     |               |
| <b>Pipe filter</b> – clean  |                |             | <b>X</b>      | <b>X</b>     |               |
| <b>Brake/parking brake</b> – check the function, escapement setting <b>25-45mm</b>  | <b>X</b>       |             |               |              |               |
| <b>Brake lining</b> – check the condition of the brake lining, min. thickness of 3mm  |                |             |               | <b>X</b>     |               |
| <b>Wheels/axle</b>  |                |             |               |              |               |
| <b>Checking the tyre pressure</b>   | <b>X</b>       |             |               | <b>X</b>     |               |
| Transport axle SF 8PS – 11PS – 500/50-17 155 A8, pressure 350 KPa   |                |             |               |              |               |
| Tracing wheels SF 8PS – 11PS – 10,0/75-15,3/14PR/F6, pressure 550 kPa   |                |             |               |              |               |
| <b>Transport axle bearings</b> – check and adjust allowance if needed (in the workshop)   |                |             |               | <b>X</b>     |               |

| <b>MAINTENANCE PLAN</b>   |                |             |               |              |               |
|---|----------------|-------------|---------------|--------------|---------------|
| Perform the planned maintenance according to the instructions:  |                |             |               |              |               |
| Maintenance Task  | Daily (season) | Once a week | Before season | After season | Time interval |
| <b>Electric cables</b>  |                |             |               |              |               |
| Check for any damage, replace if needed   |                | X           | X             |              |               |
| <b>Safety measures</b>  |                |             |               |              |               |
| <b>Lighting and safety hatched boards</b> – check the condition, function and cleanliness   | X              |             | X             |              |               |
| <b>Hazard and safety labels</b> – check that they are installed and legible   |                | X           |               |              |               |
| <b>Machine lubrication plan</b>   |                |             |               |              |               |
| <b>Drawbar joint / lifting loop</b> – grease  | X              |             |               | X            |               |
| <b>Handbrake bolt</b> – grease or suitable oil  | X              |             |               | X            |               |
| <b>Axle bearings</b> – grease with Lithium content – check, refill if needed  |                |             |               | X            |               |
| <b>After season</b>   |                |             |               |              |               |
| <b>Entire machine</b>   |                |             |               |              |               |
| <ul style="list-style-type: none"> <li>• Treat and clean the machine; do not spray oil or similar agents on the plastic parts</li> <li>• Spray the piston-rods of the hydraulic cylinders with suitable anti-corrosion agents</li> <li>• Check the tightness of all bolt and plug-in connections (see the torque chart)</li> <li>• Check for any damage of the electric cables and replace if needed</li> </ul>   |                |             |               |              |               |
| <b>Brake system</b>   |                |             |               |              |               |
| <ul style="list-style-type: none"> <li>• Preserve the anti-freeze fluid for air-brake systems (about 0.1 l ), ethanol-free, before the last ride, use fluid recommended by the tractor manufacturer.</li> <li>• Secure the machine against movement by Scotch blocks.</li> <li>• Release the parking brake, release air from the air nozzle and close the brake lines. The service brake must be released during winter so that it does not get stuck on the brake drum.</li> </ul> |                |             |               |              |               |
| <b>Points of lubrication</b>  |                |             |               |              |               |
| <ul style="list-style-type: none"> <li>• Grease the points of lubrication according to the lubrication plan, use grease <b>KP2P-20 Likx, under DIN 51 502</b></li> </ul>  |                |             |               |              |               |
| <p><b>!!! PREVENTION means removing the problem according to the plan, outside the season, without stress and comfortably before a secondary problem, an accident or a health hazard arises.</b></p>  |                |             |               |              |               |

## 11.2 Machine lubrication shedule

- During machine maintenance and its lubrication, it is necessary to observe the safety regulations.
- If the machine is equipped with a drawbar for the bottom fixed suspension, it is completely maintenance-free as far as lubrication is concerned.

| LUBRICATION POINT | INTERVAL   | LUBRICANT   |
|-------------------|--|---|
| Pole joint        | Daily, always before the work with the machine.<br>Always after the end of the season and before storing the machine | Plastic grease<br>KP2P-20 Likx<br>according to DIN 51 502 |

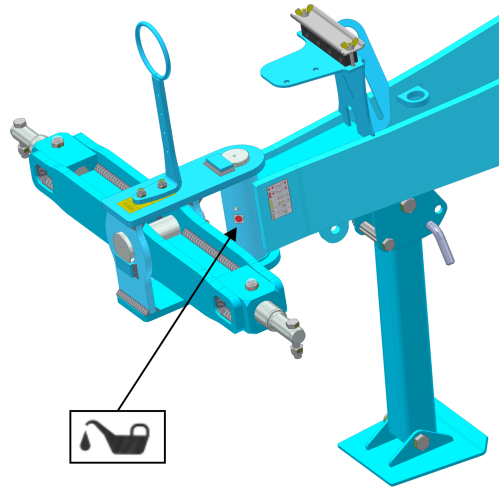

### Lubricant handling:

- Protect yourselves against direct contact with oils by using gloves or protective creams.
- Thoroughly wash oil spots on the skin using warm water and soap.
- Do not clean the skin with petrol, engine diesel fuel or other solvents.
- Oil is poisonous. If you swallowed the oil, immediately seek a physician.
- Protect the lubricants against children.



### 11.3 Replacement of the working roller bearings

- Always follow the safety regulations and directives when replacing the bearings of rollers.
- The machine must be aggregated with the tractor according to Chapter “8.1” when replacing the bearings. The tractor engine must be switched off for the replacement of bearings and the operator, or repairman, must prevent any access to unauthorised persons to the tractor
- Only replace the roller bearings on a solid and flat ground and when the machine is in standstill.
- In the case of leaks in the tractor hydraulic system, you are required to provide mechanical supports under the machine drawbar.

|                           |   |
|---------------------------|---|
|                           |   |
| <p>1 – Roller bearing</p> | <p>1 – Bolt<br/>                 2 – Spacers<br/>                 3 – Pin cylinder<br/> <math>\varnothing D</math> – 40 mm – Bolt M10 (50 Nm) / M8 (20 Nm)<br/> <math>\varnothing D</math> – 45 mm – Bolt M12 (86 Nm) / M10 (20 Nm)<br/> <math>\varnothing D</math> – 50 mm – Bolt M12 (86 Nm) / M10 (20 Nm)<br/> <math>\varnothing D</math> – 60 mm – Bolt M12 (86 Nm) / M10 (20 Nm)</p> |

### 11.3.1 Using the tool for bearing disassembly and assembly

- The location of the equipment on the machine can be found in the spare parts catalogue.

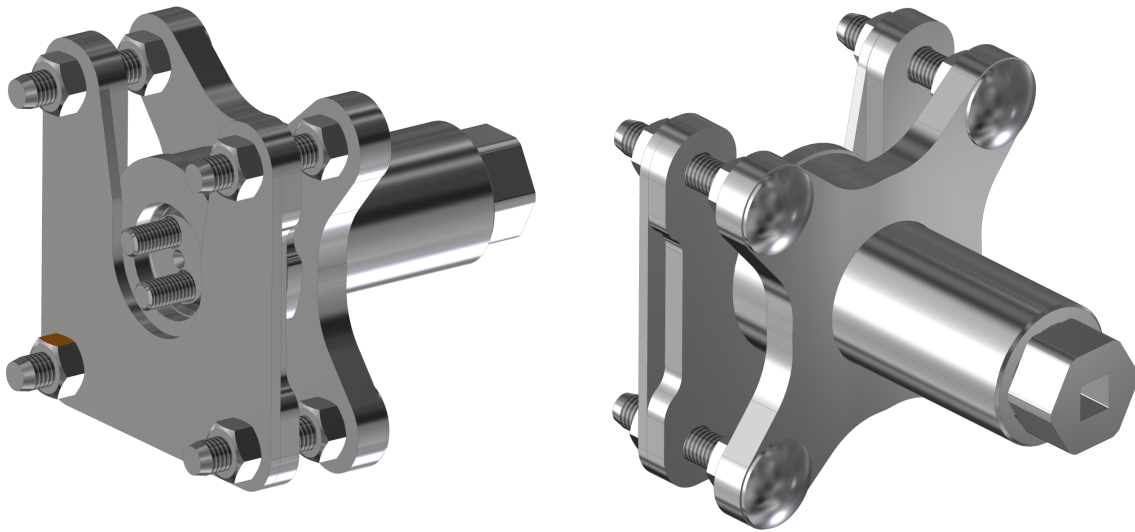

Tool parts

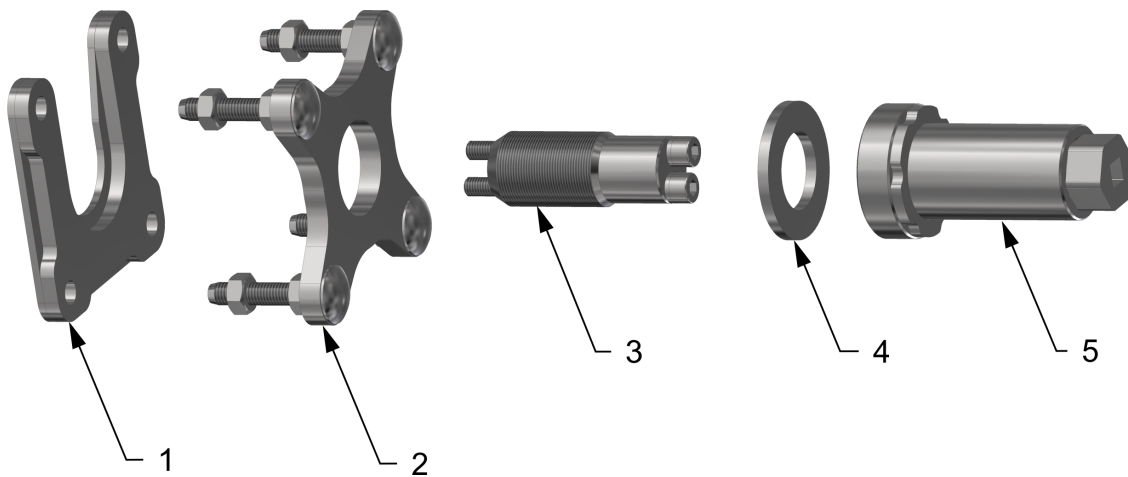

- 1 – Part for disassembling the bearing ring
- 2 – Part for disassembling the bearing or bearing ring
- 3 – Tool pin + bolts
- 4 – Liner
- 5 – Tool body

**11.3.1.1 Complete bearing disassembly**

• Procedure:

1. Mount and screw the tool pin onto the cylinder pin

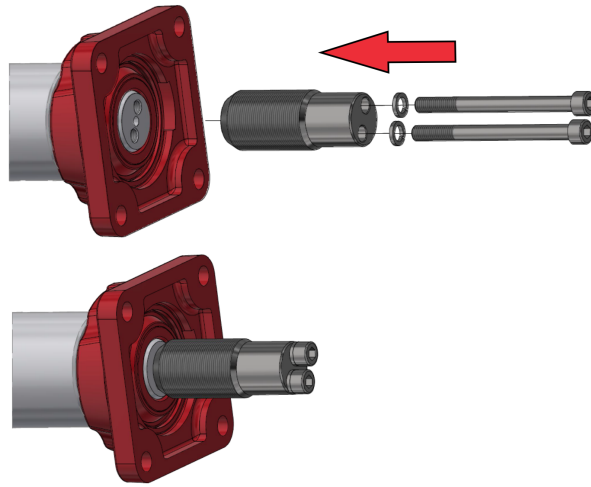

2. Screw the tool body in, insert the part for bearing disassembly and mount onto the bearing using the nuts

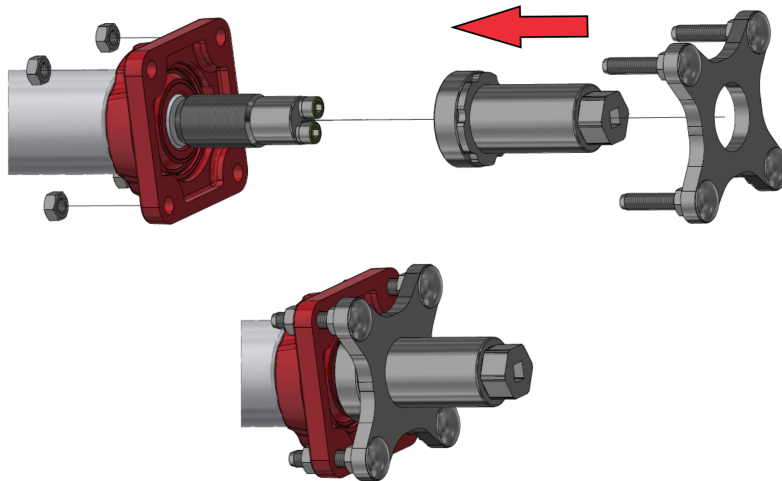

3. Disassemble the bearing by screwing the tool body using spanner size 36

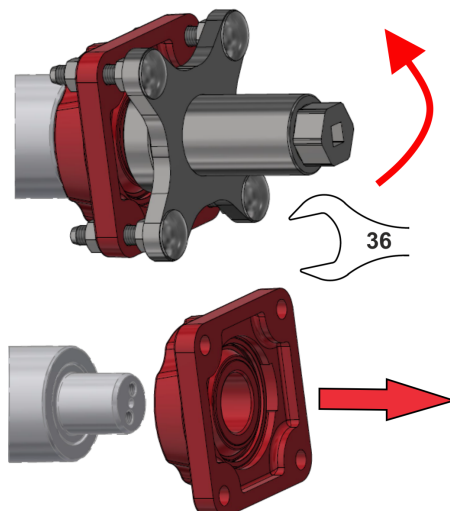

**11.3.1.2 Disassembly of the ring**

- Procedure:

1. Mount and screw the tool pin onto the cylinder pin

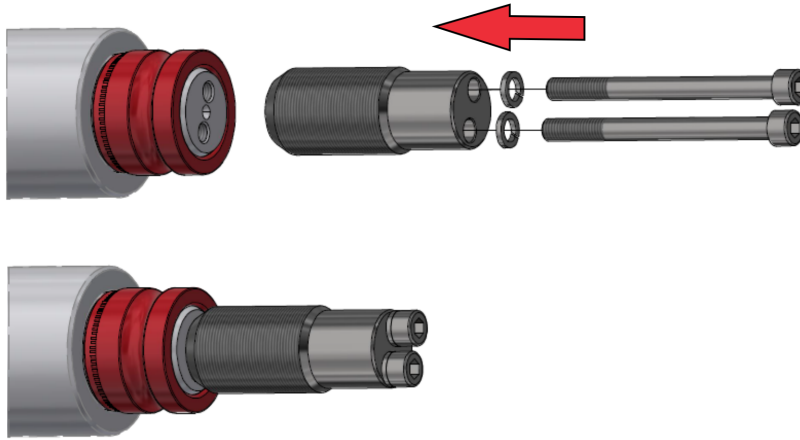

2. Screw the tool body, mount the part for disassembling the bearing, mount the part for disassembling the ring and attach it using the nuts

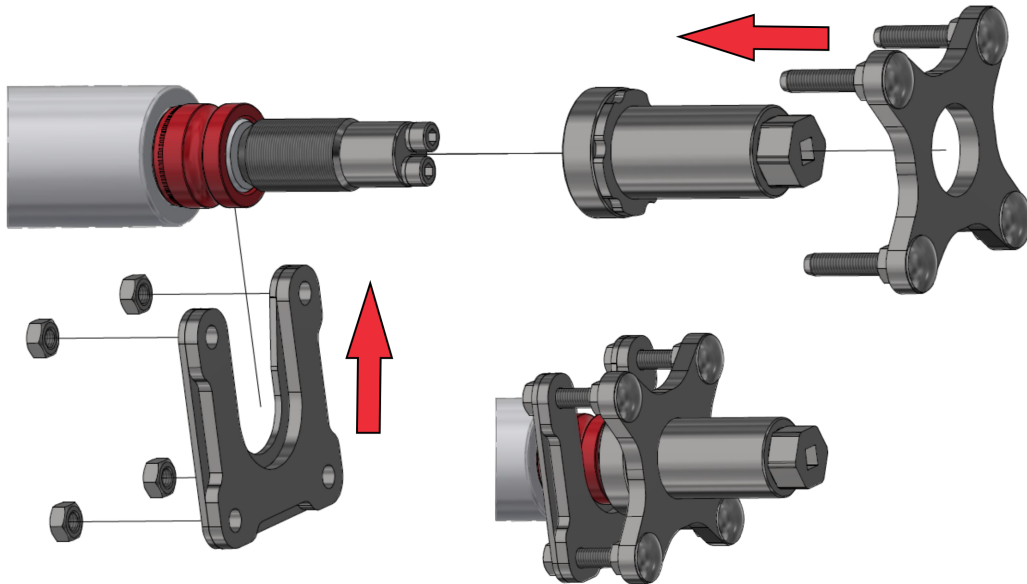

3. Disassemble the ring by screwing the tool body using spanner size 36

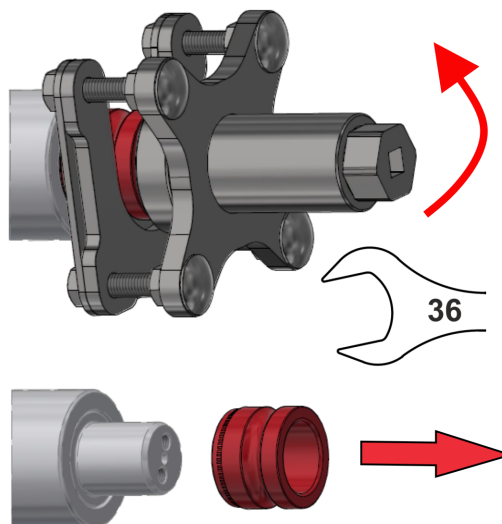

**11.3.1.3 Assembling bearings onto pins**

• Procedure:

1. Mount and screw the tool pin onto the cylinder pin

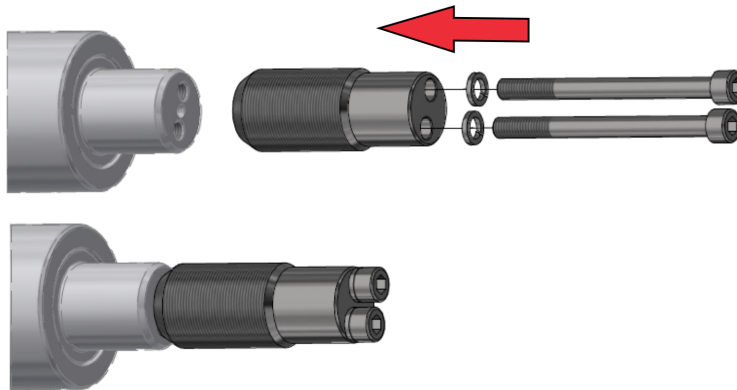

2. Mount the bearing + liner and screw the tool body in

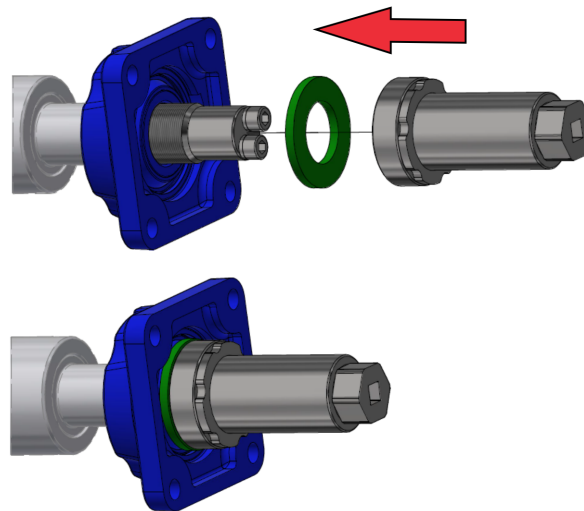

3. Assemble the bearing by screwing the tool body using spanner size 36

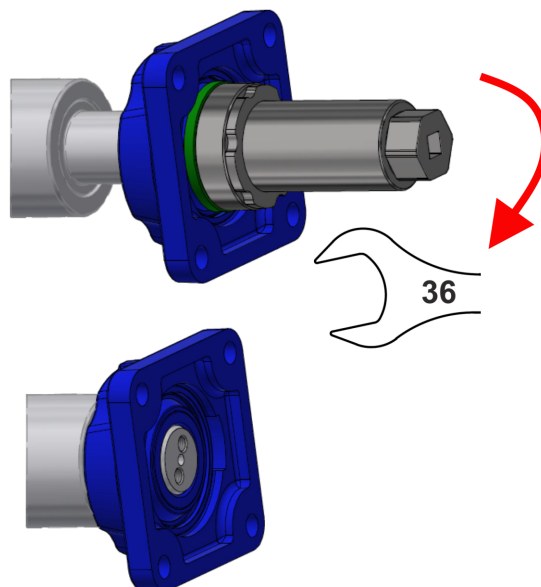

### 11.3.2 Using spacers

The spacers are used for defining production tolerances. Therefore, they do not have to be always used.

- Mount the house bearings to the rollers
- Insert the roller with the bearings between the frame side plates and assess whether you need to use the SPACERS

|                    |  |
|--------------------|--|
|                    |  |
| <p>1 – Spacers</p> | <p>1 – Side plates<br/>                 2 – Spacers<br/>                 3 – House bearing<br/>                 4 – Pin cylinder<br/>                 5 – Bolt<br/> <b>Parameter "X" = is there a gap?</b><br/>                 YES = Use spacers<br/>                 NO = Do not use spacers</p> |

## 12 MACHINE STORAGE

### Long-term machine shutdown :

- Store the machine under a roof if possible.
- Store the machine on a flat and solid surface with sufficient load capacity.
- Clean the machine before storing and conserve so that it is not damaged in any way during storage. Pay special attention to all marked lubrication points and properly lubricate them according to the lubrication plan.
- Store the machine in the position with folded frames in the transport position. Store the machine on the axle and the storage leg, secure the machine against spontaneous movement using scotches or another suitable tool.
- When storing, lower the machine into the lower position using hydraulics.
- The machine must not rest on the working parts. It could damage the working parts of the machine.
- Secure the machine against access of unauthorised persons.

## 13 ENVIROMENTAL PROTECTION

- Regularly check the tightness of the hydraulic system.
- Preventively replace or repair hydraulic hoses, possibly further parts of the hydraulic system showing signs of damage, before oil leaks occur.
- Check the condition of hydraulic hoses and perform their timely replacement. The service life of hydraulic hoses includes the time, when they were stored.
- Handle oils and greases according to valid waste laws and regulations.



## 14 MACHINE DISPOSAL AFTER SERVICE LIFE EXPIRY

- The operator must secure during machine disposal that steel parts and parts, in which hydraulic oil or lubricating grease moves are differentiated.
- Steel parts must be cut by the operator while observing safety regulations and handed over to the secondary raw material collection point. He must proceed with other parts according to valid laws about waste.

## 15 SERVICING AND WARRANTY CONDITIONS

### 15.1 Servicing

Servicing is secured by the dealer after consulting with the manufacturer, possibly directly by the manufacturer. Spare parts then using the sales network by individual sellers in the entire country. Use only the spare parts according to the spare parts catalogue officially issued by the manufacturer.

### 15.2 Warranty



- 1.** The manufacturer provides a basic warranty for the product for a period of 12 months. In the case of immediate registration of the sale to the end customer, including their valid contact details, the end customer receives an extended warranty of 36 months. The warranty is provided from the date the product is handed over to the end user (buyer). The registration must be completed by the seller (sales representative) on the My Farmet online portal. Upon correct registration, the end user will gain access to the My Farmet portal and all the benefits of the extended warranty.
- 2.** The warranty covers hidden defects that manifest during the warranty period under proper use of the machine and in compliance with the conditions specified in the Operating Manual.
- 3.** The warranty does not cover consumable spare parts, i.e., normal mechanical wear and tear of replaceable working parts (shares, discs, harrow tines, roller bearings, etc.).
- 4.** The warranty is tied to the machine and does not terminate with a change of ownership. The extended warranty is conditional upon registering the new owner's contact details in the My Farmet portal.
- 5.** The warranty is limited to disassembly and assembly, replacement, or repair of the defective part. The decision on whether the defective part will be replaced or repaired lies with the manufacturer, Farmet.
- 6.** During the warranty period, repairs or other interventions on the machine may only be carried out by an authorized service technician of the manufacturer. Otherwise, the warranty will not be recognized. This provision does not apply to the replacement of consumable spare parts (see point 3).
- 7.** The warranty is conditional upon the use of original spare parts supplied by the manufacturer.

2011/001/07

(CZ) ES PROHLÁŠENÍ O SHODĚ  
 (GB) CE CERTIFICATE OF CONFORMITY  
 (D) EG-KONFORMITÄTSERLÄRUNG  
 (F) DÉCLARATION CE DE CONFORMITÉ  
 (RU) СЕРТИФИКАТ СООТВЕТСТВИЯ ЕС  
 (PL) DEKLARACJA ZGODNOŚCI WE

1. (CZ) My (GB) We (D) Wir (F) Nous (RU) Мы (PL) My: **Farmet a.s.**  
 Jiřínková 276  
 552 03 Česká Skalice  
 Czech Republic  
 DIČ: CZ46504931  
 Phone: +420 491 450 111

(CZ) Vydáváme na vlastní zodpovědnost toto prohlášení. (GB) Hereby issue, on our responsibility, this Certificate. (D) Geben in alleiniger Verantwortung folgende Erklärung ab. (F) Publiions sous notre propre responsabilité la déclaration suivante. (RU) Под свою ответственность выдаем настоящий сертификат. (PL) Wydajemy na własną odpowiedzialność niniejszą Deklarację Zgodności.

2. (CZ) Strojní zařízení: - název : **Diskový podmičák**  
 (GB) Machine: - name : **Disk plough-harrow**  
 (D) Fabrikat: - Bezeichnung : **Kurzscheibenegge**  
 (F) Machinerie: - dénomination : **Déchaumeur à disques**  
 (RU) Сельскохозяйственная машина: - наименование : **Дисковый лущильник**  
 (PL) Urządzenie maszynowe: - nazwa : **Talerzowy pług podorywkowy**
- typ, type : **SOFTER**  
 - model, modèle : **SOFTER 4 P | 4 PS | 4,5 PS | 5 PS | 6 PS | 8 PS | 11 PS**  
 - PIN/VIN :
- (CZ) výrobní číslo :   
 - (GB) serial number  
 - (D) Fabriknummer  
 - (F) n° de production  
 - (RU) заводской номер  
 - (PL) numer produkcyjny

3. (CZ) Příslušná nařízení vlády: č.176/2008 Sb. (směrnice 2006/42/ES). (GB) Applicable Governmental Decrees and Orders: No. 176/2008 Sb. (Directive 2006/42/ES). (D) Einschlägige Regierungsverordnungen (NV): Nr. 176/2008 Slg. (Richtlinie 2006/42/ES). (F) Décrets respectifs du gouvernement: n°.176/2008 du Code (directive 2006/42/CE). (RU) Соответствующие постановления правительства: № 176/2008 Сб. (инструкция 2006/42/ES). (PL) Odpowiednie rozporządzenia rządowe: nr 176/2008 Dz.U. (Dyrektywa 2006/42/WE).

4. (CZ) Normy s nimiž byla posouzena shoda: (GB) Standards used for consideration of conformity: (D) Das Produkt wurde gefertigt in Übereinstimmung mit folgenden Normen: (F) Normes avec lesquelles la conformité a été évaluée: (RU) Нормы, на основании которых производилась сертификация: (PL) Normy, według których została przeprowadzona ocena: ČSN EN ISO 12100, ČSN EN ISO 4254-1.

(CZ) Schválil (GB) Approve by date: 02.01.2025  
 (D) Bewilligen (F) Approuvé  
 (RU) Утвердил (PL) Uchwalil

**Ing. Petr Lukášek**  
 Technical director

V České Skalici date: 02.01.2025

**Ing. Tomáš Smola**  
 Director of the Agricultural Technology Division