

# **OPERATING MANUAL**

# **STRIP-TILL**

## **ST4N | ST6NS | ST8NS**

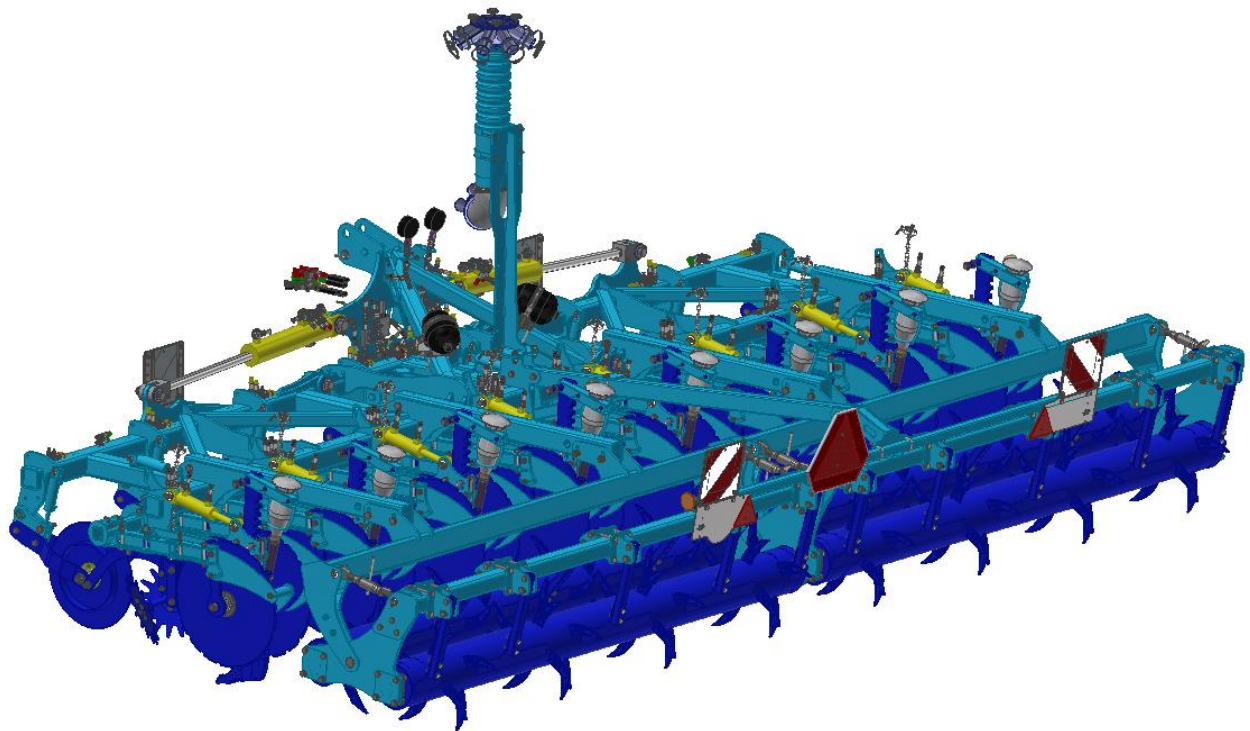

**Edition: 3 | effective from: 01. 08. 2021**

Dear customer,  
Carried cultivators **STRIP-TILL** are quality products of Farnet a.s. Ceska Skalice.

You can fully utilise the advantages of your machine after thoroughly studying the operating manual. The serial number of the machine is punched on the production label and written in the operating manual (see Table 1). This machine serial number must be stated whenever ordering spare parts for possible repairs. The production label is located on the middle frame, on the left side of the hitch.

Use only spare parts for these machines according to the **Spare parts catalogue** officially issued by the manufacturer, Farnet a.s. Ceska Skalice.

**Possibilities of Use of the Cultivator**

The **STRIP-TILL** cultivator is designed for cultivation of all types of soils up to a processing depth of 350 mm.

Production label of the machine **STRIP-TILL ST 4N**

				Farnet a.s. Jiřínková 276 Česká Skalice
TYP / VARIANTA	STRIP-TILL ST4N			
ČÍSLO SCHVÁLENÍ	_____			
ROK VÝROBY / VÝROBNÍ ČÍSLO	_____			
MAX. PŘÍPUSTNÁ HMOTNOST	1650	kg		
MAX. PŘÍPUSTNÁ HMOTNOST NA NÁPRAVĚ	_____	kg		

Production label of the machine **STRIP-TILL ST 6NS**

				Farnet a.s. Jiřínková 276 Česká Skalice
TYP / VARIANTA	STRIP-TILL ST6NS			
ČÍSLO SCHVÁLENÍ	_____			
ROK VÝROBY / VÝROBNÍ ČÍSLO	_____			
MAX. PŘÍPUSTNÁ HMOTNOST	3355	kg		
MAX. PŘÍPUSTNÁ HMOTNOST NA NÁPRAVĚ	_____	kg		

Production label of the machine **STRIP-TILL ST 8NS**

				Farnet a.s. Jiřínková 276 Česká Skalice
TYP / VARIANTA	STRIP-TILL ST8NS			
ČÍSLO SCHVÁLENÍ	_____			
ROK VÝROBY / VÝROBNÍ ČÍSLO	_____			
MAX. PŘÍPUSTNÁ HMOTNOST	3765	kg		
MAX. PŘÍPUSTNÁ HMOTNOST NA NÁPRAVĚ	_____	kg		

Table 1 – Your Machine Characteristic

<b>MACHINE TYPE</b>	
<b>MACHINE SERIAL NUMBER</b>	
<b>SPECIAL DESIGN OR ACCESSORIES</b>	<p>.....</p> <p>.....</p> <p>.....</p> <p>.....</p>

## TABLE OF CONTENTS

Machine limit parameters .....	4
Technical parameters .....	4
Safety statement .....	4
A. GENERAL INSTRUCTIONS FOR USE .....	5
B. MACHINE TRANSPORT USING TRANSPORT MEANS .....	6
C. MACHINE HANDLING USING LIFTING EQUIPMENT .....	6
D. WORK SAFETY LABELS .....	6
1. DESCRIPTION .....	8
Machine operation principle .....	8
Work parts of the machine .....	8
2. MACHINE ASSEMBLY AT THE CUSTOMER .....	9
3. COMMISSIONING .....	9
3.1 Aggregation to a tractor .....	10
3.2 Hydarulics connection .....	11
3.3 Folding and unfolding of the machine .....	12
3.4 Hydraulics machine protection function .....	13
4. MACHINE TRANSPORT ON ROADS .....	16
5. ADJUSTING THE WORKING DEPTH OF THE MACHINE .....	18
6. MACHINE MAINTENANCE AND REPAIR .....	21
7. MACHINE STORAGE .....	21
8. ENVIRONMENTAL PROTECTION .....	22
9. MACHINE DISPOSAL AFTER SERVICE LIFE EXPIRITY .....	22
10. SERVICING AND WARRANTY CONDITIONS .....	22
CE Certificate of Conformity .....	23

## MACHINE LIMIT PARAMETERS

- <sup>(x)</sup> The machine is designed for soil cultivation up to a depth of 35 cm when agricultural soil cultivation. Another type of use exceeding the determined purpose is forbidden.
- <sup>(x)</sup> The machine is only operated by one person - the tractor operator.
- <sup>(x)</sup> Machine operator must not use the machine in a different way, especially:
  - <sup>(x)</sup> Transport of persons and animals on the machine structure,
  - <sup>(x)</sup> Transport of burdens on the machine structure,
  - <sup>(x)</sup> Aggregation of the machine with another towing equipment than stated in Chapter „3.1./p.10“.



## TECHNICAL PARAMETERS

Table 2 – technical parameters





PARAMETERS	ST 4N	ST 6NS	ST 8NS
Working width (mm)	3000	4500	6000
Transport width (mm)	3000	3000	3000
Transport height (mm)	1800	2600	3350
Machine total length (mm)	3050		
Working depth (mm)	max. 350		
Number of shares	4	6	8
Working performance (ha/h)	2,4 – 3	3,6 – 4,5	4,8 – 6
Towing means (kW)	90-150*	135-225*	180-300*
Working speed (kph)	8–10		
Maximum transport speed (kph)	20		
Maximum slope grade (°)	6		
Machine weight (kg)	1650	3355	3765

\* Recommended towing means, the real towing force may significantly vary according to the processing depth, soil conditions, land slope, working body wear and adjustment

## SAFETY STATEMENT

	This warning sign warns about an immediate dangerous situation ending with death or severe injury.
	This warning sign warns about a dangerous situation ending with death or severe injury.
	This warning sign warns about a situation that may end with a smaller or slight injury. It also warns about dangerous actions related to the activity that could lead to an injury.

## A. GENERAL INSTRUCTIONS FOR USE

- A.1** <sup>(x)</sup> The machine is made in accordance with the latest equipment state and approved safety regulations. However, dangers of user or third person injury or machine damage or creation of other material damage may arise during use.
- A.2** <sup>(xx)</sup> Use the machine only in a technically sound condition, in accordance with its purpose, aware of possible dangers, and while adhering to the safety instructions of this operating manual!  
The manufacturer is not liable for damages caused by the use of the machine that is in contradiction with the limit parameters of the machine and with the instructions for the use of the machine. The user bears the risk.  
Immediately remove especially the failures that may negatively affect safety!
- A.3** <sup>(7)</sup> Machine operation may be performed by a person authorised by the operator under these conditions:
- <sup>(8)</sup> It must own a valid driver's licence of the corresponding category,
  - <sup>(9)</sup> It must be demonstrably familiarised with the safety regulations for work with the machine and must practically master the machine operation,
  - <sup>(10)</sup> The machine may not be operated by juveniles,
  - <sup>(11)</sup> It must know the meaning of the safety signs located on the machine. Their respecting is important for safe and reliable machine operation.
- A.4** <sup>(12)</sup> Maintenance and servicing repairs on the machine may only be performed by a person:
- <sup>(13)</sup> Authorised by the operator,
  - <sup>(14)</sup> Educated in the machinery field with knowledge of repairs of similar machines,
  - <sup>(15)</sup> Demonstrably familiarised with safety regulations for work with the machine,
  - <sup>(16)</sup> During a repair of a machine connected to a tractor, it must own a driver's licence of the corresponding category.
- A.5** <sup>(17)</sup> Machine operator must secure the safety of other persons when working with the machine or transporting the machine.
- A.6** <sup>(18)</sup> During machine work in the field or during transport, the operator must control the machine from the tractor's cabin.
-  **A.7** <sup>(19)</sup> The operator may enter the machine structure only with the machine at rest and blocked against movement, namely only for these reasons:
- <sup>(20)</sup> Adjustment of the machine working parts,
  - <sup>(21)</sup> Repair and maintenance of the machine.
-  **A.8** <sup>(xxx)</sup> When climbing on the machine, do not step on the axle tyres, rollers or other revolving parts. Those may turn and you can cause very serious injuries by the subsequent fall.
-  **A.9** <sup>(22)</sup> Any changes or modifications of machine may be performed only with written consent of the manufacturer. For possible damage arisen due to ignoring this instruction, the producer bears no responsibility. The machine must be maintained equipped with prescribed accessories and equipment including safety marking. All warning and safety signs must be legible and in their places. In case of damage or loss, these signs must be immediately renewed.
- A.10** <sup>(23)</sup> The operator must have the Operating Manual with the work safety requirements available at any time when working with the machine.
-  **A.11** <sup>(24)</sup> The operator must not consume alcohol, medicines, narcotic and hallucinogenic substances that decrease his attention and coordination capabilities while using the machine. If the operator must use medicines prescribed by a physician or uses freely sold medicines, he must be informed by a physician, whether he is capable of responsible and safe operation of the machine under these circumstances.

### PROTECTIVE TOOLS

For the operation and maintenance use



- Tight clothes
- Protective gloves and goggles for protection against dust and sharp parts
- of the machine



## B. MACHINE TRANSPORT USING TRANSPORT MEANS

- B.1 <sup>(1)</sup> The transport means designed for machine transport must have the load capacity minimally identical with the weight of the transported machine. The total weight of the machine is stated on the production label.
-  B.2 <sup>(2)</sup> The dimensions of the transported machine including the transport means must comply with the valid regulations for road traffic (decrees, laws).
- B.3 <sup>(3)</sup> The transported machine must be always fastened to the transport means so that its spontaneous loosening could not happen.
- B.4 <sup>(4)</sup> The carrier is responsible for damage caused by the loosening of incorrectly or insufficiently fastened machine to the transport means.

## C. MACHINE HANDLING USING LIFTING EQUIPMENT

- C.1 <sup>(1)</sup> The lifting equipment and tying means designed for handling of the machine must have their load capacity at least identical with the weight of the handled machine.
-  C.2 <sup>(2)</sup> Machine fastening for handling may only be performed in places designed for that and marked with self-adhesive labels showing the "chain" symbol. 
- C.1 <sup>(3)</sup> After fastening (suspending) at designated points, it is forbidden to move in the space of possible reach of the handled machine.

## D. WORK SAFETY LABELS



Warning safety labels serve for operator protection.

General:

- A) Strictly observe the warning safety labels.
- B) All safety instructions also apply to other users.
- C) Upon damage or destruction of the aforementioned "SAFETY LABEL" located on the machine, THE OPERATOR IS OBLIGED TO REPLACE IT WITH A NEW ONE!!!

The position, appearance, and precise meaning of work safety labels on the machine is determined in the following tables (Tab. 3) and in the figure (Fig. 1).

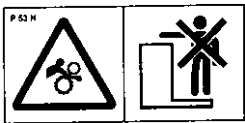
Table 3 – Self-adhesive warning safety labels located on the cultivator

WARNING SAFETY LABEL	LABEL TEXT	MACHINE POSITION
	Stay outside the reach of the tractor - agricultural machine set, if the tractor engine is in operation.	<b>P 53 H</b>
	Before handling the machine, carefully read the operating manual.  Observe the instructions and safety regulations for machine operation during use.	<b>P 1 H</b>
	When folding and unfolding the side frames, stay outside their reach.	<b>P 50 H</b>

	<p>Travelling and transport on the machine structure is strictly forbidden.</p>	<p><b>P 37 H</b></p>
	<p>When connecting or disconnecting, do not step between the tractor and the machine, also do not enter this space, if the tractor and the machine are not at rest and the engine is not turned off.</p>	<p><b>P 2 H</b></p>
	<p>Before commencing the machine transport, secure the axle with spherical valves against unexpected drop.</p>	<p><b>P 100 H</b></p>
	<p>Stay out of reach of the drawn-up machine.</p>	<p><b>P 4 H</b></p>
	<p>When folding the side frames, do not reach into the space of the machine folding joints. There is a danger of cutting when setting the depth of the machine.</p>	<p><b>P 20 H</b></p>
	<p>Stay outside the reach of the tractor - agricultural machine set, if the tractor engine is in operation.</p>	<p><b>P 6 H</b></p>

Fig.1 – Location of safety labels on the machine

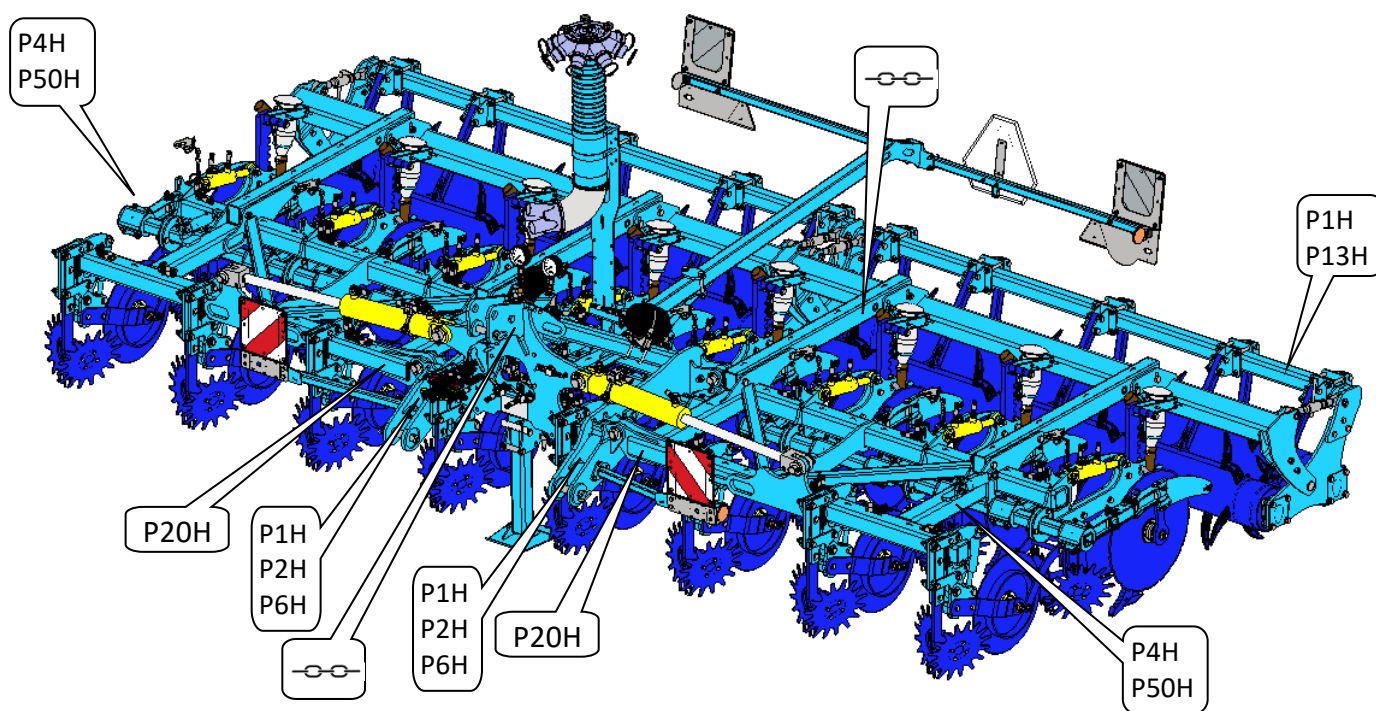



## 1. DESCRIPTION

**STRIP TILL** is designed as a mounted machine, equipped with the TBZ 3 hitch. The machine consists of a central frame and two folding side frames where the working units are mounted, consisting of front cutting discs, crop residue spreaders, loosening ploughshares and packing discs. The rear spiked rollers are also mounted on the frames. The side frames fold using linear hydraulic motors connected to the external hydraulic circuit.

### MACHINE OPERATION PRINCIPLE

**STRIP TILL** is designed for strip soil cultivation when soil is processed in strips of 70 cm/75 cm. It is most suitable for wide-row crops as it helps prevent loss of soil moisture and provides an anti-erosion effect.

The front cutting discs break up soil in the centre of the processed strip and they are partially lowered down. The crop residue spreaders bring crop residue into the unprocessed strips in-between. The massive ploughshares loosen soil and when a guiding system is used, fertilizer can be applied at two depth levels. The side packing discs keep the loosened soil in the defined strip (the discs can be set according to the soil type and cultivation depth). The rear spiked rollers break up the loosened strip.

### WORK PARTS OF THE MACHINE

Fig.2 – work parts of the machine

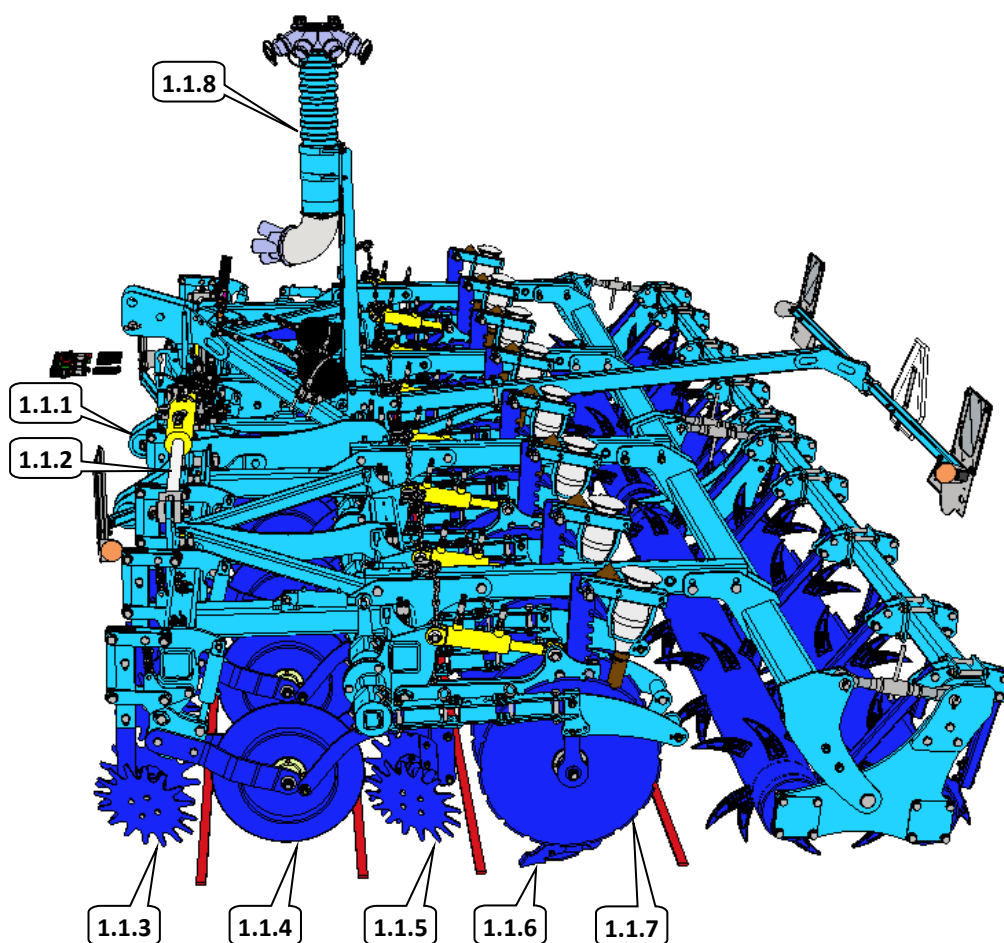

- 1.1.1 TBZ towing bracket
- 1.1.2 Side frame folding hydraulic cylinder
- 1.1.3 Front crop residue spreaders – optional equipment for extra charge
- 1.1.4 Front cutting discs



- 1.1.5 Crop residue spreaders
- 1.1.6 Ploughshares for loosening with a fertilizer outlet
- 1.1.7 Side packing discs
- 1.1.8 Fertilizer or manure distribution – optional equipment for extra charge

## 2. MACHINE ASSEMBLY AT THE CUSTOMER



- The operator must perform the assembly according to the instructions of the producer, best in cooperation with the expert servicing technician determined by the producer.
- The operator must secure a functional test of all assembled parts after the completion of the machine assembly.
- The operator must secure that the handling of the machine using lifting equipment during its assembly is in accordance with chapter „C“.

## 3. COMMISSIONING



- Before taking over the machine, test and check, whether damage occurred during transport and whether all parts contained in the bill of delivery were supplied.
- Before commissioning the machine, carefully read this operating manual, especially Chapters **A-D**. Before the first use of the machine, familiarise yourselves with its controls and overall function.
- During work with the machine, observe not only the instructions of this operating manual but also generally valid regulations of work safety, health protection, fire and transport safety, and environmental protection.
- The operator must check the machine before every use (commissioning) from the standpoint of completeness, work safety, work hygiene, fire safety, transport safety, and environmental protection. A machine showing signs of damage must not be commissioned.
- Aggregation of the machine with the tractor is to be performed on a flat and hardened surface.
- When working on slopes, observe the lowest slope grade of the set **TRACTOR – MACHINE**.
- Before starting the tractor motor, check whether no person or animal is in the working space of the set and push the warning sound signal.
- The operator is responsible for the safety and all damage caused by the operation of the tractor and the connected machine.
- The operator is obliged to adhere to the technical and safety regulations of the machine determined by the producer when working.
- The operator is obliged to retract the working bodies of the machine from the ground when turning at the headland.
- The operator is obliged to observe the prescribed working depths and speeds stated in the manual in Tabl.2 when working with the machine.
- The operator is obliged to lower the machine to the ground and secure the set against movement before leaving the tractor cabin.
- Pay extra attention when lowering the machine down; avoid a sudden impact with paved surface to prevent damage to the chisels and ploughshares. Place the machine on a flat surface so that the weight of the machine is evenly distributed on all ploughshares.

### 3.1 AGGREGATION TO A TRACTOR

- The machine can be connected only to a tractor, whose curb weight is identical or higher than the overall weight of the connected machine.
- The machine operator must observe all generally valid regulations of work safety, health protection, fire safety, and environmental protection.
- The operator may connect the machine exclusively to a tractor that is equipped with a rear three-point suspension and a functional undamaged hydraulic system.
- The table of requirements for the towing means for work with the machine:

<sup>(5)</sup> Requirement for the tractor engine power for cultivator STRIP-TILL ST4N			90-150 kW*
<sup>(5)</sup> Requirement for the tractor engine power for cultivator STRIP-TILL ST6NS			135-225 kW*
<sup>(5)</sup> Requirement for the tractor engine power for cultivator STRIP-TILL ST8NS			180-300 kW*
<sup>(6)</sup> Requirement for the bottom hitch	<sup>(7)</sup> Spacing of the lower suspension joints (measured at the joint axes)	TBZ 3	895±1,5 mm 1100±1,5 mm
		KIROVEC	1110±1,5 mm
	<sup>(8)</sup> Ø of the hole of the lower suspension joints for the machine suspension pivots	TBZ 3	37,4 – 37,75 mm
		KIROVEC	60,5 – 61 mm
	<sup>(18)</sup> Ø of the hole of the upper suspension joint for the machine suspension pivot	TBZ 3	32,0 – 32,25 mm
		KIROVEC	39,5 – 40 mm
<sup>(9)</sup> Requirement for the tractor's hydraulic system	Side frame folding circuit		<sup>(14)</sup> Circuit pressure 200 bar, 2 pcs of quick-coupler sockets ISO 12,5
	Front cutting disc hydraulic protection circuit		
	Loosening ploughshare hydraulic protection circuit		
	Circuit for setting the hydraulic pressure of the side packing discs		

\* Recommended towing means, the real towing force may significantly vary according to the processing depth, soil conditions, land slope, working body wear and adjustment

- Connect the machine using the TPS suspension bar to the lower arms of the rear TPS of the tractor, secure the TPS arms using pins against disconnecting.
- The machine aggregated with the tractor changes the distribution of the weight to the individual axles of the tractor. The weight of the front axle is reduced and therefore the controllability gets worse. It also affects braking properties.



**When connecting, no persons may stay in the space between the tractor and the machine.**

### 3.2 HYDARULICS CONNECTION

- Connect the hydraulics only when the hydraulic circuits of the machine and the tractor (aggregate) are in a pressure-less condition.
- The hydraulic system is under high pressure. Regularly check for leaks and immediately remove obvious damage of all lines, hoses, and pipe unions.
- When seeking and removing leaks, use only the suitable tools.
- For connecting the hydraulic system of the machine to the tractor, use the plug (on the machine) and the socket (on the tractor) of the quick couplers of the same type.

Hydraulic circuit functions:

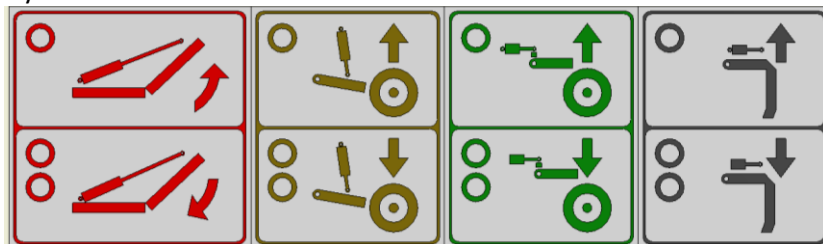

**Red circuit** – machine folding

**Yellow circuit** – setting the hydraulic pressure of the front discs

**Green circuit** – setting the hydraulic pressure of the side discs

**Black circuit** – setting the protection hydraulic pressure



In order to prevent accidental movement of the hydraulics or movement caused by an unauthorized person (children, passengers), the control switchboards on the tractor must be secured or blocked in the transport position.

### 3.3 FOLDING AND UNFOLDING OF THE MACHINE

- - 
  -
- Reduce the speed of the moving parts of the machine by throttling the respective valve on the control unit for all hydraulic movements before the end stop!
  - The hydraulics for the folding and unfolding must be connected to the double-action control unit.
  - The operator must ensure that during folding and unfolding of the side frames, no person or animal is within their reach (i.e. at the place of their impact) or vicinity, and that no-one puts their fingers in the joint space.
  - If the machine is equipped with telescopic discs, the operator must ensure that the discs are drawn in the transport position and secured with pins before folding and unfolding.
  - Perform folding and unfolding on flat and solid surfaces or laterally to the slope with the fully open control unit.
  - Folding and unfolding may only be performed when the machine is lifted on the tractor hitch.
  - Remove stuck soil from folding points, soil may impair function and cause damage to the mechanics.
  - During folding or unfolding, check the side frames and have them continuously fold into the end position to the stoppers.

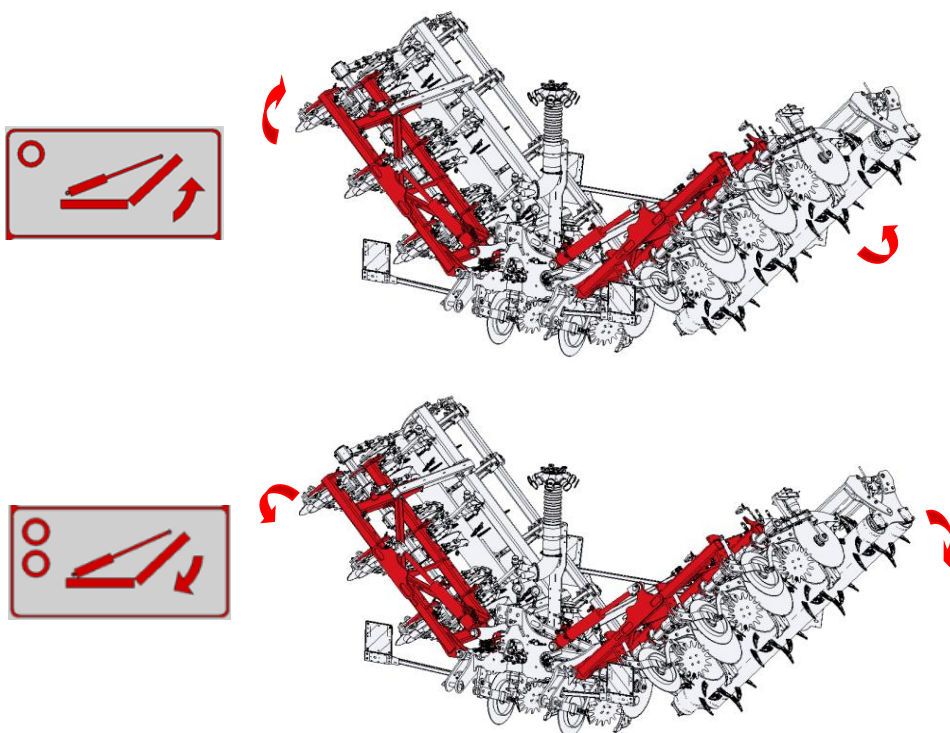

**After unfolding the machine:**

1. When the machine is unfolded, open the valve, see the picture below.
2. All working units can be drawn in – using the hose marked with one black strip.

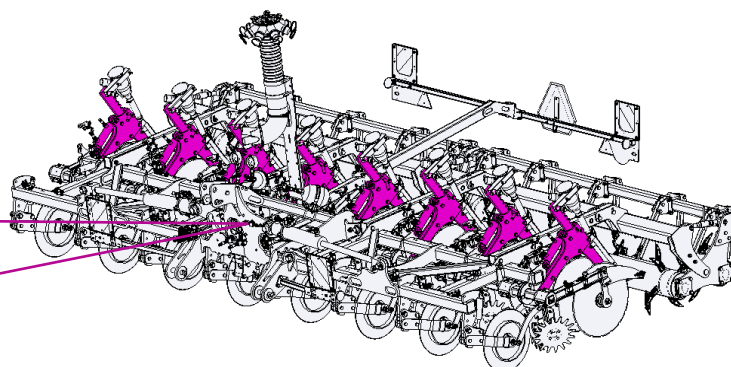
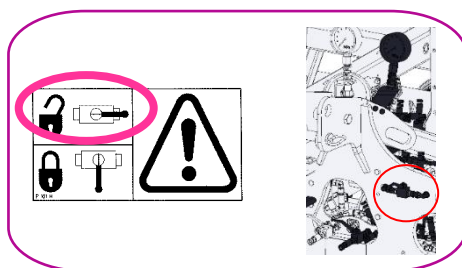
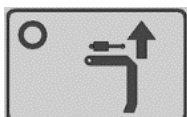

### 3.4 HYDRAULICS MACHINE PROTECTION FUNCTION

- The hydraulic protection of the front cutters and the shares is provided by pressure accumulators.
- To ensure proper function, the **protection circuits** must be pressurized to **80 bar** and left in the **floating position**.
- Furthermore, the circuits of the hydraulic machine protection are equipped with two ball valves, one per circuit.
- The ball valves facilitate disconnection of the hydraulic quick-couplers from the tractor switchboard by making it possible to depressurize the inlet hydraulic hoses of the front cutting disc protection circuit and the ploughshare protection circuit, while maintaining the pressure in the front cutting disc protection circuit and in the ploughshare protection circuit, which is required for a safe shut-down of the machine.



**PRESSURE VESSEL**  
Never open or adjust (welding, drilling etc.) the pressure vessel (pressure accumulator). The pressure vessel is still under gas pressure even after it has been emptied. Empty the pressure vessel in case of any work on the hydraulics of the machine. The manometer must not show any pressure, or the pressure on the manometer must decrease to 0 bars. Only then it is permitted to work on the hydraulic circuit.

The diagram illustrates the correct procedure for working on a hydraulic pressure vessel. It shows two scenarios: 1) A pressure vessel with a manometer showing a pressure above 0 bar. A callout box indicates that work (represented by crossed-out wrench and hammer icons) is prohibited, accompanied by a red 'X' in a circle. 2) A pressure vessel with a manometer showing 0 bar. A callout box indicates that work (represented by wrench and hammer icons) is permitted, accompanied by a green checkmark in a circle.

### Setting the front cutting disc hydraulic protection

1. Check that the hydraulic hoses are connected properly under 3.2.
2. Check that the ball valve of the front cutting disc protection circuit is open; if not, open it.
3. Pressurize the circuit of the **front cutting disc protection to 80 bar** – using the hose marked with two yellow strips; monitor the pressure on the yellow-coded manometer.
4. Set the **yellow circuit in the floating position** in the tractor switchboard
5. The protection is now prepared for work.

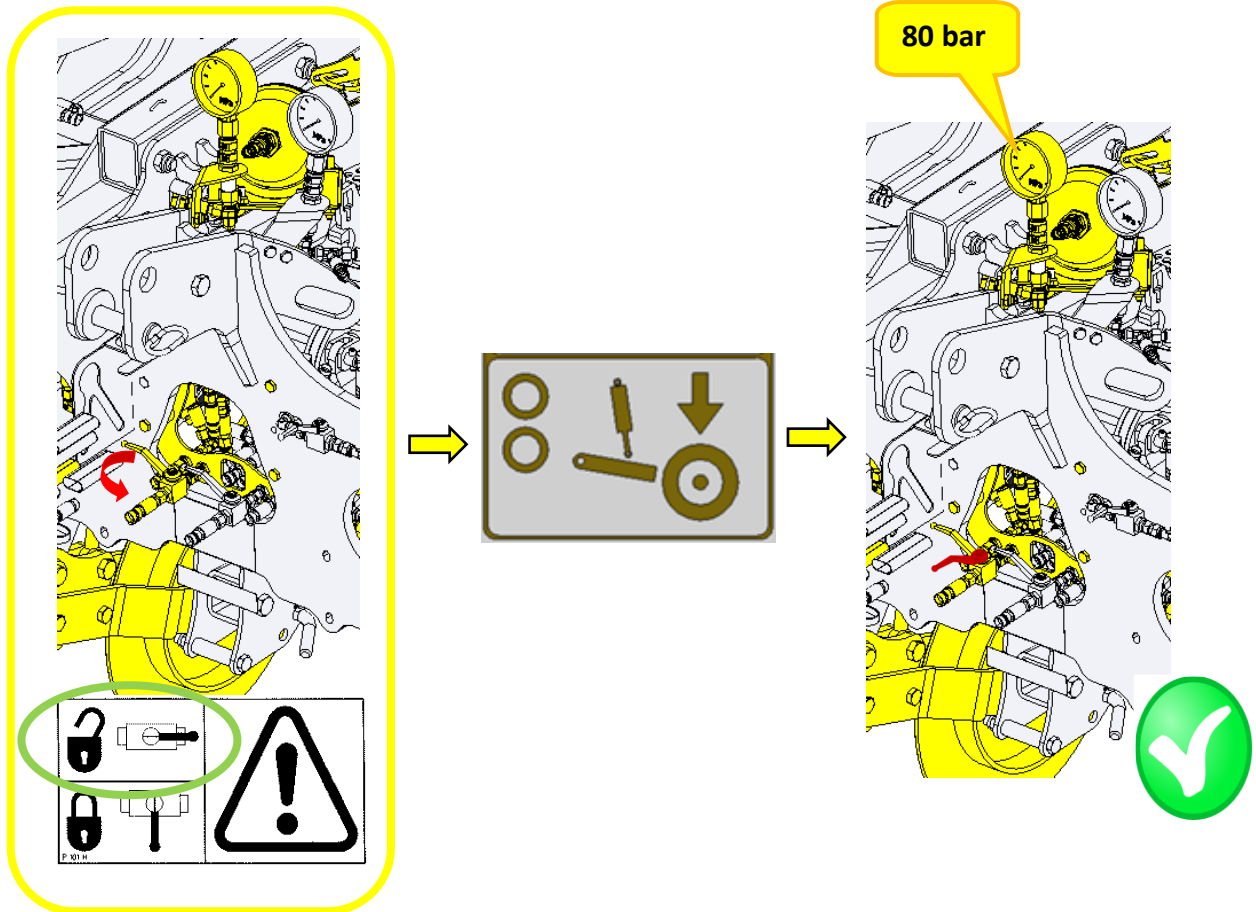



### Setting the ploughshare hydraulic protection

1. Check that the hydraulic hoses are connected properly under 3.2.
2. Check that the ball valve of the ploughshare protection circuit is open; if not, open it.
3. Pressurize the circuit of the **ploughshare protection to 80 bar** – using the hose marked with two black strips; monitor the pressure on the black-coded manometer.
4. Set the **black circuit in the floating position** in the tractor switchboard
5. The protection is now prepared for work.

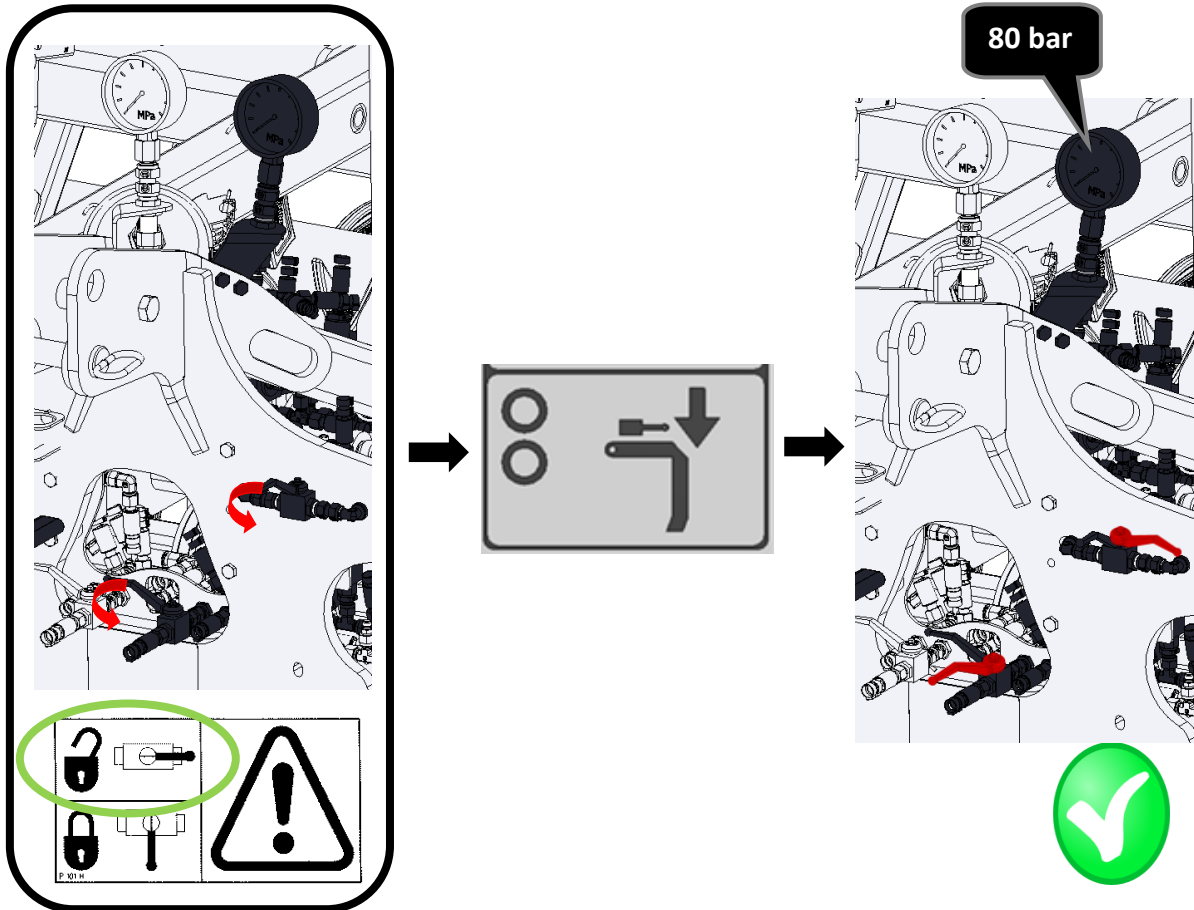

## 4. MACHINE TRANSPORT ON ROADS



### Transport position of **STRIP-TILL**

- Connect the machine by suspending on the tractor using the three-point suspension equipment.
- Fold the side frames to the transport position.
- The machine must be equipped with removable shields with marking of contours, functional lighting, and the board of the rear marking for slow vehicles (according to ECE No. 69).
- The lighting must be activated during travelling on roads.
- The tractor must be equipped with a special light device of an orange colour, which must be activated during travelling on roads.
- The maximum transport speed during travelling on roads is **20 kph**.
- Secure the lower shoulders of the tractor TPS from side swing.



### Ban of transport with decreased visibility!

- Bring the machine into the transport position.
- The operator is obliged to pay increased attention during transport on roads, due to the transport dimensions of the machine.
- The operator must observe the valid regulations for transport on roads (laws, decrees) after connecting the machine to the tractor, for reason of a change of the axle load. The driving properties of the set also change depending on the terrain nature, adapt the manner of driving to these conditions.
- The operator is obliged to present the machine certificate of roadworthiness as needed, according to the valid regulations for road traffic (decree, law) (only in the Czech Republic).
- The operator is obliged to secure sufficient outlook during reversing from his position of the tractor driver. In case of insufficient outlook, the operator is obliged to call a competent and informed person.
- The operator must secure the arms of the rear TPS of the tractor in the transport position during road transport, i.e. prevent unexpected arm drop using the hydraulic arm control lever. At the same time, the arms of the rear TPS of the tractor must be secured against side swinging.
- During machine transport on roads, the operator must observe the valid laws and decrees that deal with this topic, and which specify the relationships of the tractor axle load depending on transport speed.

### Folding the machine into transport position

1. Close the ball valve, see picture below.
2. Draw the working units on the side frames in – using the hose marked with one black strip.
3. Fold the machine – using the hose marked with one red strip.
4. The machine is prepared for transport.

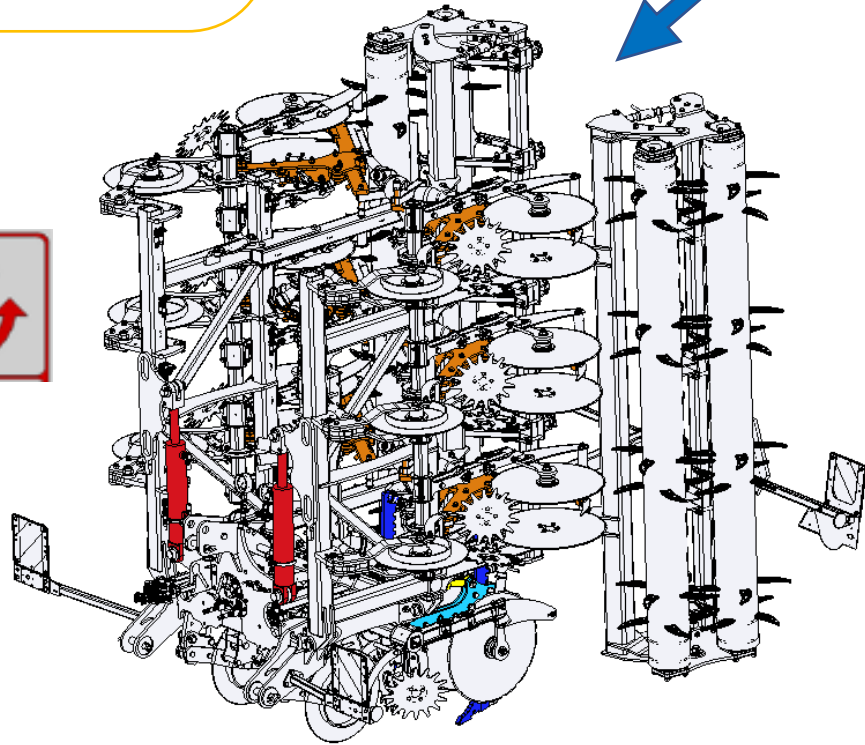
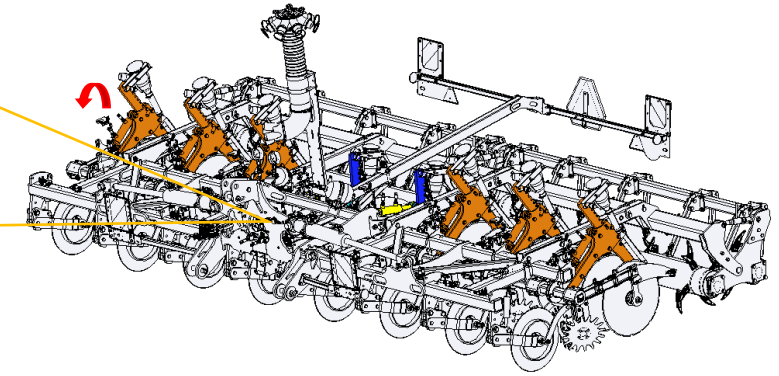
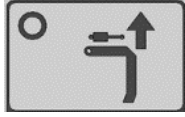

## 5. ADJUSTING THE WORKING DEPTH OF THE MACHINE



Only adjust the machine when it is resting on the ploughshares, or when it is recessed (see below).

1. Set the lengthwise plain of the machine by the position of the bottom tractor arms and adjusting the drawbar of the third tractor point.
2. Set the working depth of the machine by extending or drawing in the tine in the holder.

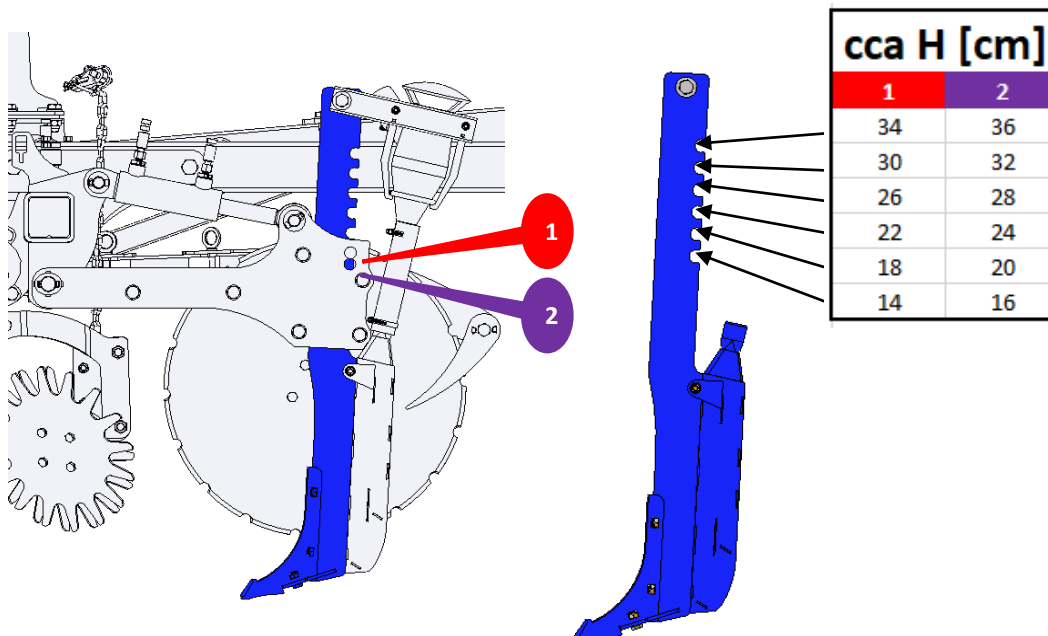
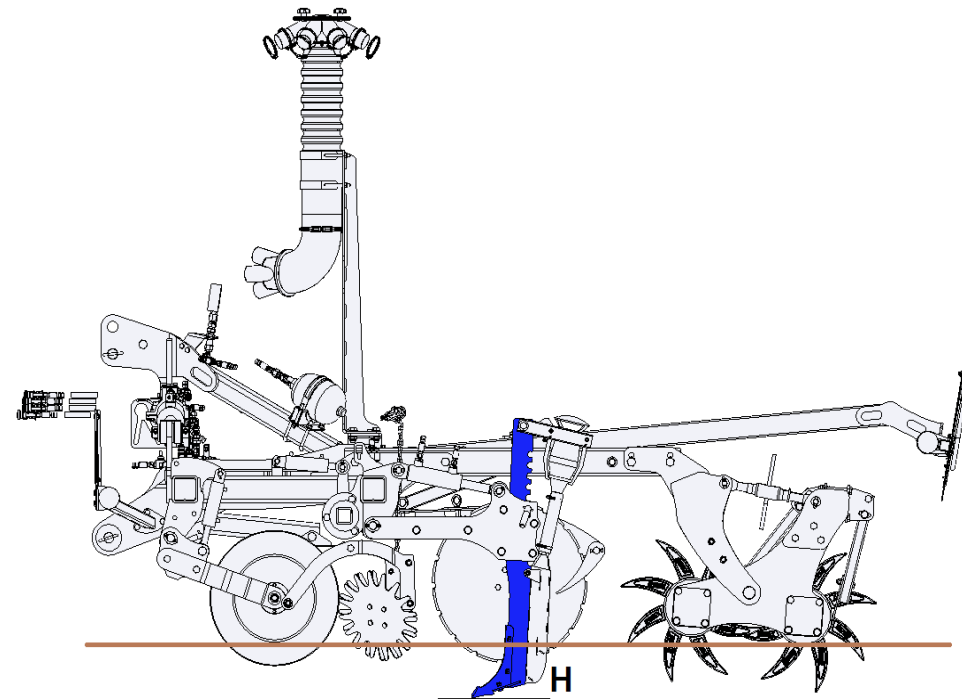

3. Set the crop residue spreaders so that they work with their own weight. If the soil is light and without crop residue, it is recommended to deactivate the discs.

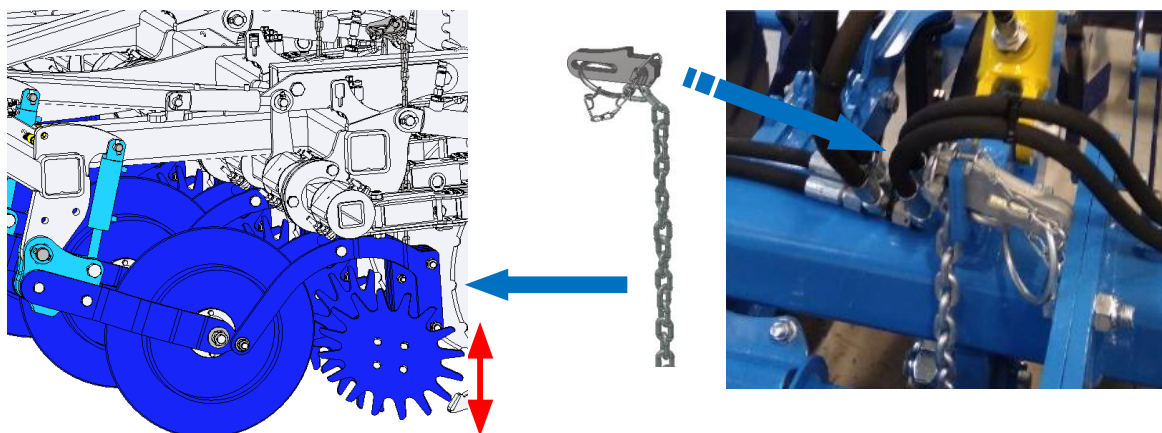

4. Set the packing discs by changing the position of the pins according to the current conditions so that soil stays within the defined loosened strip. The discs can be set lengthwise, crosswise and angularly. The depth and down pressure can be set hydraulically. Pay extra attention during the setting.

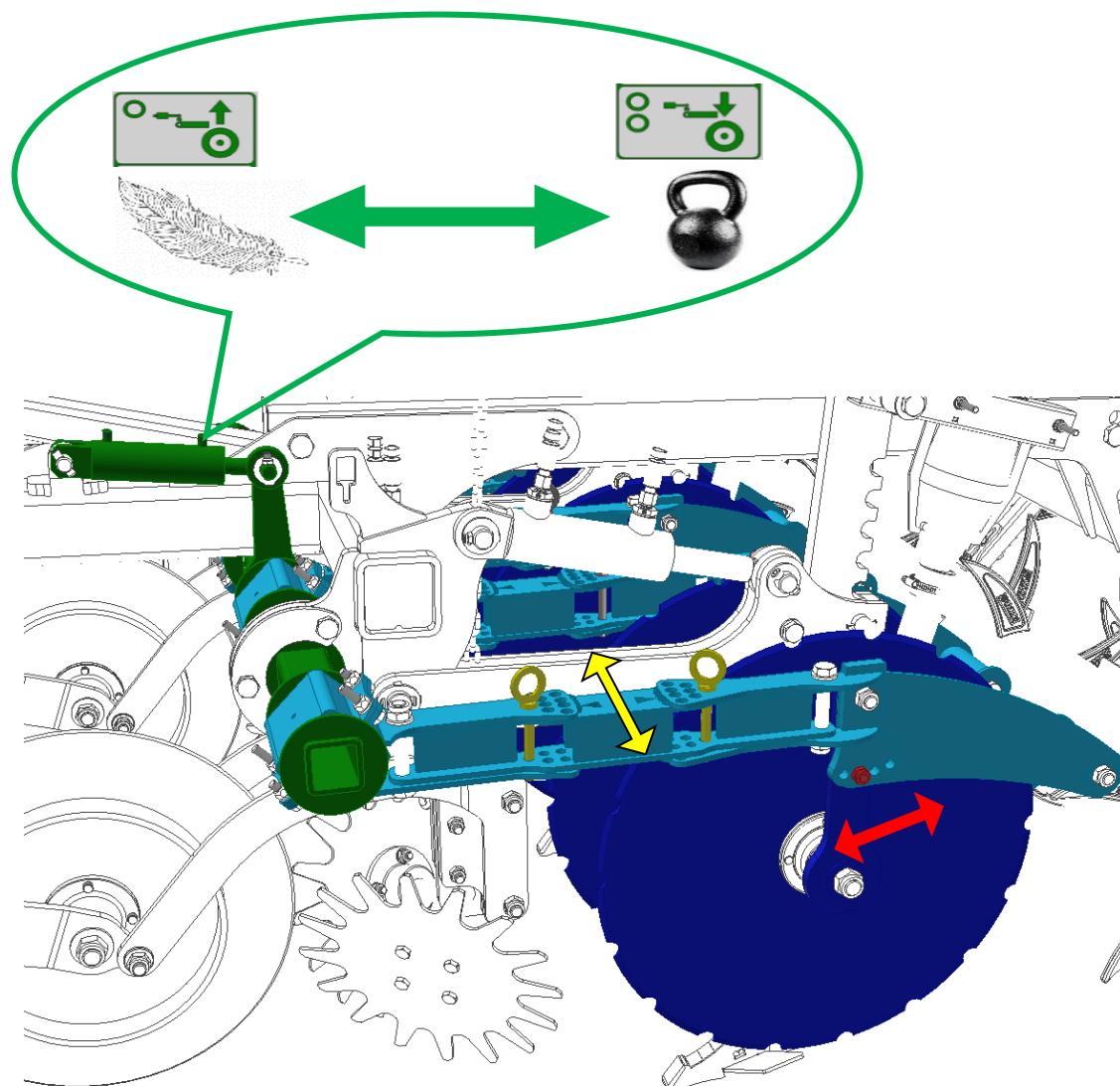

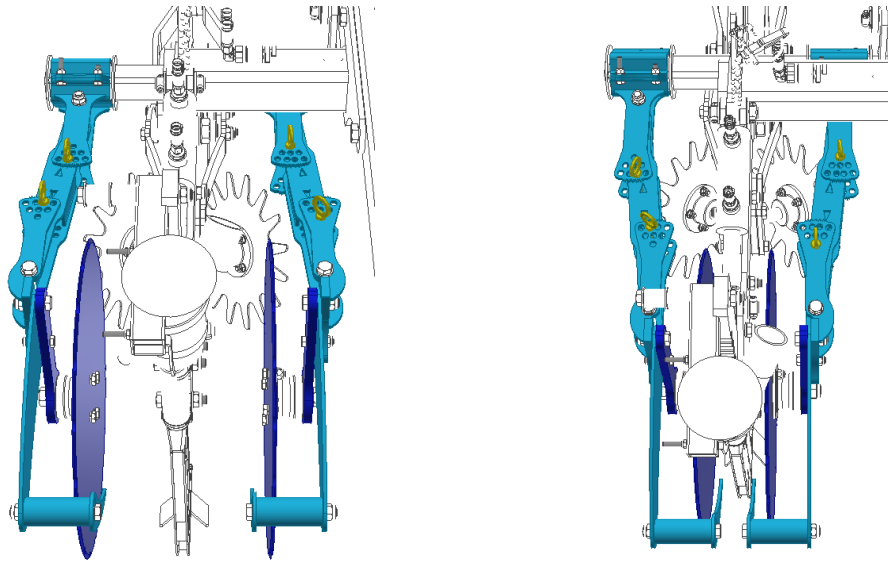

5. Set the down pressure of the spiked roller using the adjusting pins.

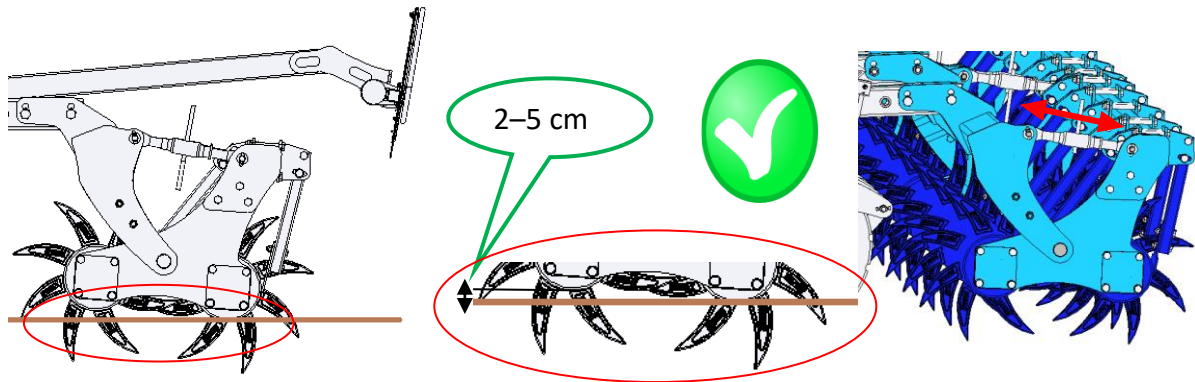

6. Set the down pressure of the front spreading discs by extending/drawing in the tine in the holder.

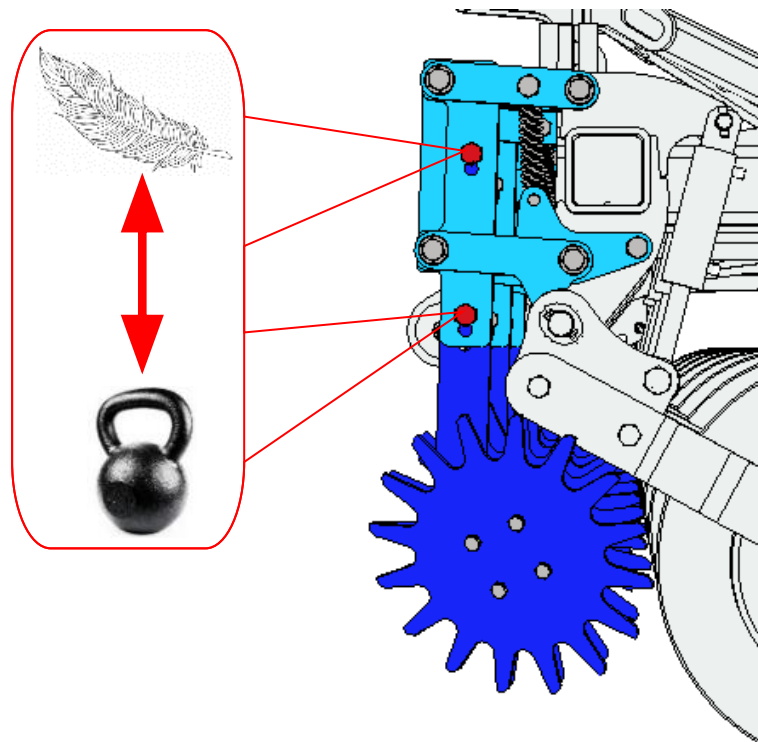



## 6. MACHINE MAINTENANCE AND REPAIR



### Observe the safety instructions for treatment and maintenance.



- If it is necessary to weld during the repair and have the machine connected to the tractor, it must have disconnected supply cables from the alternator and the accumulator.
- Check the tightening of all screw and other assembly connections at the machine before every use of the machine, furthermore continuously as needed.
- Continuously check the wear of the working bodies of the machine, possibly replace these worn working bodies with new ones.
- Adjustment, cleaning, and lubrication of the machine may only be performed with the machine at rest (i.e. the machine is standing and not working).
- Plants and other residues potentially caught on the shaft by the bearing have to be removed, otherwise the bearing will get damaged.
- When working on a lifted machine, use suitable support equipment supported at marked points or at points suitable for that.
- During adjustment, cleaning, maintenance, and repair of the machine, you must secure those parts of the machine that could endanger the operator by falling or another movement.
- For catching the machine during handling using lifting equipment, use only the places marked with self-adhesive labels with the chain sign "—○—○—".
- Upon a failure or damage of the machine, immediately turn off the tractor's engine and secure against restarting, secure the machine against movement ⇒ only then you can remove the failure.
- During repairs of the machine, use exclusively the genuine spare parts, suitable tools and protective equipment.
- Keep the machine clean.
- Lower the machine with caution so that the chisels and shares are not damaged by sharp lowering to the ground.



**Do not clean hydraulic cylinders and bearings with a high-pressure cleaner or direct water stream. The seals and bearings are not watertight at high pressure.**

## 7. MACHINE STORAGE

Long-term machine shutdown:

- Store the machine under a roof if possible.
  - Store the machine on a flat and solid surface with sufficient load capacity.
  - Clean the machine before storing and conserve so that it is not damaged in any way during storage. Pay special attention to all marked lubrication points and properly lubricate them according to the lubrication plan.
  - When not using the machine, leave it in an unfolded position leaning against the rear roller, the support leg and the front spreading discs. Support the tines with a suitable bracket (such as a piece of wood) or draw the working units in so that the chisel tips are above the ground. If you do not have a suitable support available, disassemble the chisels. **If the machine is left resting on the chisels, the weight of the machine may damage them. There is a risk of damage even when the machine is standing on an uneven surface for a short period of time when the machine weight is only transferred to some chisels.**
-   ▪ Secure the machine against access of unauthorised persons.

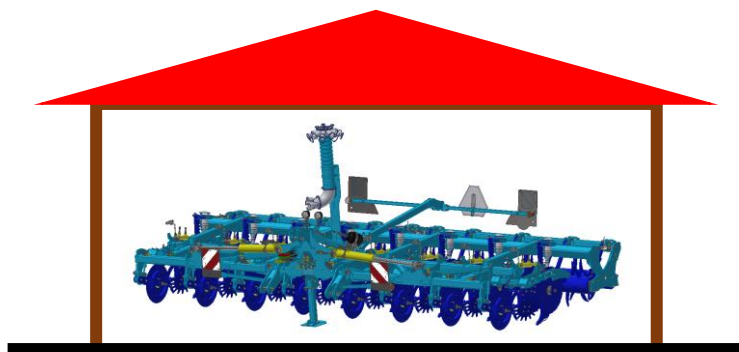

## **8. ENVIRONMENTAL PROTECTION**

- Secure the machine against access of unauthorised persons.

## **9. MACHINE DISPOSAL AFTER SERVICE LIFE EXPIRY**

- The operator must secure during machine disposal that steel parts and parts, in which hydraulic oil or lubricating grease moves are differentiated.
- Steel parts must be cut by the operator while observing safety regulations and handed over to the secondary raw material collection point. He must proceed with other parts according to valid laws about waste.

## **10. SERVICING AND WARRANTY CONDITIONS**

### **10.1 SERVICING**

Servicing is secured by the dealer after consulting with the manufacturer, possibly directly by the manufacturer. Spare parts then using the sales network by individual sellers in the entire country. Use only the spare parts according to the spare parts catalogue officially issued by the manufacturer.

### **10.2 WARRANTY**

- 10.2.1 The manufacturer provides a warranty of 24 months for these machine parts: main frame, axle, and machine tow bar. For other parts of the machine, the manufacturer provides a warranty of 12 months. The warranty is provided from the date of sale of the new machine to the end user (consumer).
- 10.2.2 The warranty applies to hidden defects that will show in the warranty period with proper use of the machine and while fulfilling the conditions stated in the operating manual.
- 10.2.3 The warranty does not apply to wearable spare parts, i.e. regular mechanical wear and tear of replaceable parts of the working sections (shares, edges etc.).
- 10.2.4 The warranty does not apply to indirect consequences of possible damage, such as service life decrease etc.
- 10.2.5 The warranty is bound to the machine and is not void upon an owner change.
- 10.2.6 The warranty is limited to the disassembly and assembly, possibly replacement or repair of the defective part. The decision, whether to replace or repair the defective part, is up to the contractual workshop of Farmet.
- 10.2.7 During the warranty period, only the authorised servicing technician of the manufacturer may perform repairs or other interventions into the machine. In the opposite case, the warranty will not be acknowledged. This provision does not apply to the replacement of wearable spare parts (see point 10.2.3).
- 10.2.8 The warranty is conditioned by using the genuine spare parts of the manufacturer.

**ⒸZ ES PROHLÁŠENÍ O SHODĚ**  
**ⒸGB CE CERTIFICATE OF CONFORMITY**  
**ⒸD EG-KONFORMITÄTSEKTLÄRUNG**  
**ⒸF DÉCLARATION CE DE CONFORMITÉ**  
**ⒸRU СЕРТИФИКАТ СООТВЕТСТВИЯ ЕС**  
**ⒸPL DEKLARACJA ZGODNOŚCI WE**

1. ⒸZ My ⒸGB We ⒸD Wir ⒸF Nous ⒸRU Мы ⒸPL My: **Farmet a.s.**  
 Jiřinková 276  
 552 03 Česká Skalice  
 Czech Republic  
 DIČ: CZ46504931  
 Tel/Fax: 00420 491 450136

ⒸZ Vydáváme na vlastní zodpovědnost toto prohlášení. ⒸGB Hereby issue, on our responsibility, this Certificate. ⒸD Geben in alleiniger Verantwortung folgende Erklärung ab. ⒸF Publiions sous notre propre responsabilité la déclaration suivante. ⒸRU Под свою ответственность выдаем настоящий сертификат. ⒸPL Wydajemy na własną odpowiedzialność niniejszą Deklarację Zgodności.

2. ⒸZ Strojní zařízení: - název : **Dlátový kypřič**  
 ⒸGB Machine: - name : **Chisel cultivator**  
 ⒸD Fabrikat: - Bezeichnung : **Meißelgrubber**  
 ⒸF Machinerie: - dénomination : **Cultivateur à siceaux**  
 ⒸRU Сельскохозяйственная машина: - наименование : **Чизельный культиватор**  
 ⒸPL Urządzenie maszynowe: - nazwa : **Spulchniarka dłutowa**

- typ, type : **STRIP-TILL**  
 - model, modèle : **STRIP-TILL 4N, 6NS, 8NS**  
 - PIN/VIN:

- ⒸZ výrobní číslo :   
 - ⒸGB serial number  
 - ⒸD Fabriknummer  
 - ⒸF n° de production  
 - ⒸRU заводской номер  
 - ⒸPL numer produkcyjny:

3. ⒸZ Příslušná nařízení vlády: č.176/2008 Sb. (směrnice 2006/42/ES). ⒸGB Applicable Governmental Decrees and Orders: No.176/2008 Sb. (Directive 2006/42/ES). ⒸD Einschlägige Regierungsverordnungen (NV): Nr.176/2008 Slg. (Richtlinie 2006/42/ES). ⒸF Décrets respectifs du gouvernement: n°.176/2008 du Code (directive 2006/42/CE). ⒸRU Соответствующие постановления правительства: № 176/2008 Сб. (инструкция 2006/42/ES). ⒸPL Odpowiednie rozporządzenia rządowe: nr 176/2008 Dz.U. (Dyrektywa 2006/42/WE).

4. ⒸZ Normy s nimiž byla posouzena shoda: ⒸGB Standards used for consideration of conformity: ⒸD Das Produkt wurde gefertigt in Übereinstimmung mit folgenden Normen: ⒸF Normes avec lesquelles la conformité a été évaluée: ⒸRU Нормы, на основании которых производилась сертификация: ⒸPL Normy, według których została przeprowadzona ocena: ČSN EN ISO 12100, ČSN EN ISO 4254-1.

ⒸZ Schválil ⒸGB Approve by dne: 01.08.2021  
 ⒸD Bewilligen ⒸF Approuvé  
 ⒸRU Утвердил ⒸPL Uchwalił

Ing. Petr Lukášek  
 technický ředitel  
 Technical director



**Farmet a.s.**  
 Jiřinková 276  
 552 03 Česká Skalice  
 DIČ CZ46504931

59

V České Skalici dne: 01.08.2021

Ing. Karel Žďárský  
 generální ředitel společnosti  
 General Manager

