

OPERATING MANUAL

SOFTER

SF500PRO | SF600PRO

SF700PRO | SF800PRO

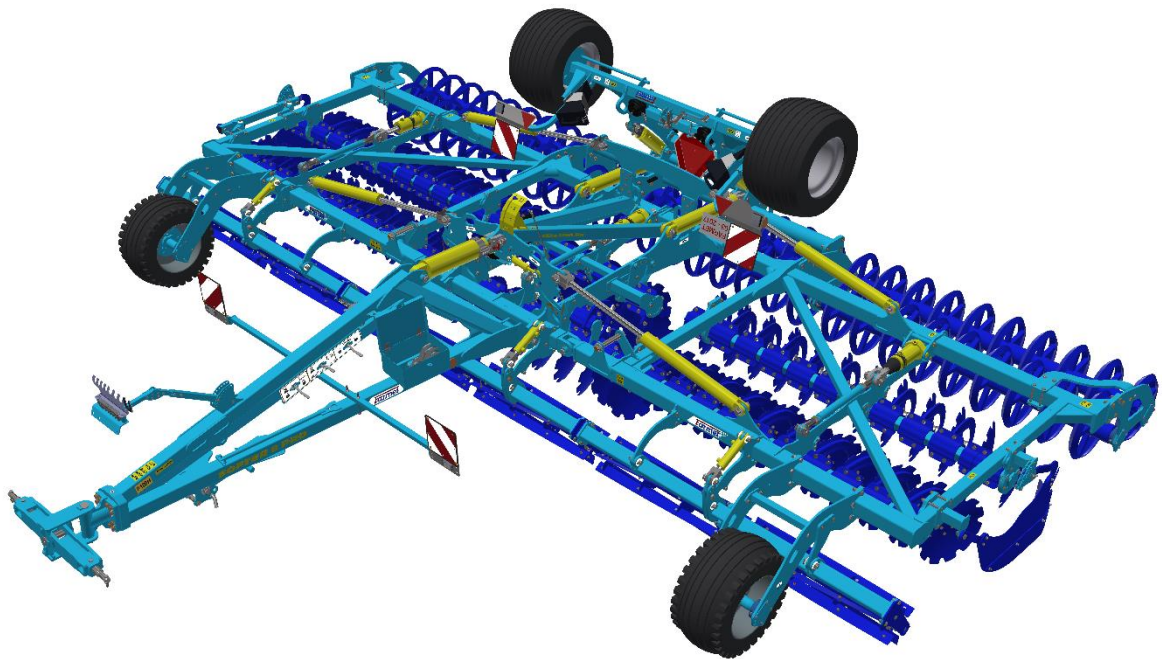

Edition : 4 | effective from: 1. 4. 2024

Dear Customer,

The agricultural machine you have purchased is a high-quality product of Farmet a.s. Česká Skalice
You can fully utilise the advantages of your machine after thoroughly studying the operating manual.

The serial number of the machine is punched on the production label and written in the operating manual (see Table 1). This machine serial number must be stated whenever ordering spare parts for possible repairs. The production label is located on the middle frame near the tow bar.

Use only spare parts for these machines according to the **Spare parts catalogue** officially issued by the manufacturer, Farmet a.s. Ceska Skalice.

Possibilities of Use of the machine

The **SOFTER PRO** disc plough-harrow is intended for ploughing all types of soil up to the depth of 13cm (5.12 in).

Production label of the machine

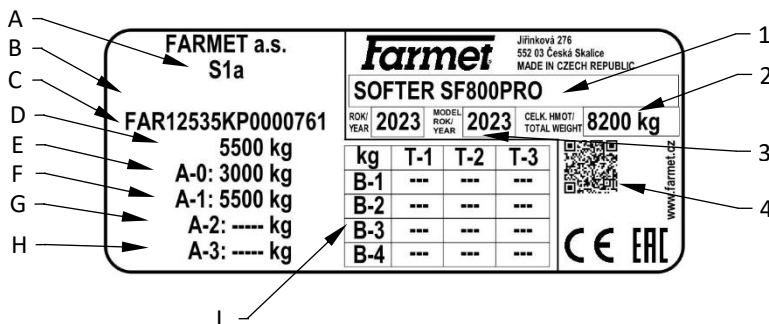

A	Vehicle category according to R167/2013
B	Approval number
C	Seventeen digit serial number (VIN)
D	Technically permissible maximum laden mass of the vehicle
E	Maximum vertical load on the coupling point
F	Permissible load – axle 1
G	
H	
J	Technically permissible towable mass for each chassis/braking configuration for R or S category vehicle
1	Commercial name, general description and purpose
2	Total weight
3	Year of production
4	QR code, specific machine designation

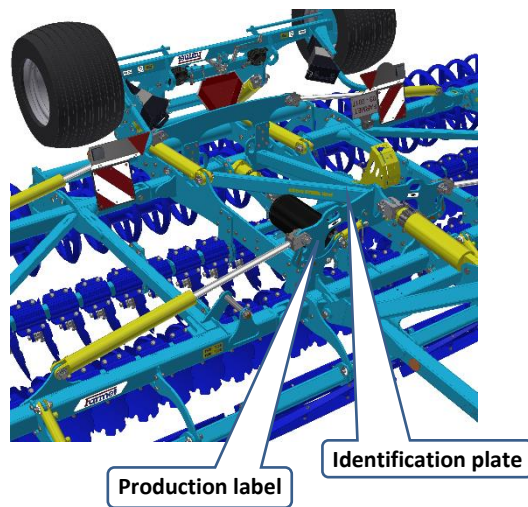

Table 1 – Your Machine Characteristics

MACHINE TYPE	
MACHINE SERIAL NUMBER	
SPECIAL DESIGN OR ACCESSORIES	
.....	
.....	
.....	
.....	

TABLE OF CONTENTS

MACHINE LIMIT PARAMETERS	5
Technical parameters	5
Safety statement	6
A. GENERAL INSTRUCTIONS FOR USE	7
Protective tools	7
B. MACHINE TRANSPORT USING TRANSPORT MEANS	8
C. MACHINE HANDLING USING LIFTING EQUIPMENT	9
D. WORK SAFETY LABELS	10
1 DESCRIPTION	14
1.1 Working parts of the machine	14
1.2 Hydraulic valve function	15
1.3 Hydraulic diagram of the machine	16
1.4 Brake distribution of the machine	17
1.4.1 Brake distribution diagram	17
1.4.2 Hand brake control valve	18
1.4.3 Emergency pneumatic brake control	18
1.5 Lighting equipment	19
1.6 Hydraulic frame lock (SF800PRO, SF700PRO)	20
1.7 Mechanical frame lock (SF600PRO, SF500PRO)	20
1.8 Transport rests on the axle	21
1.9 Device against unauthorized use	22
1.10 Wheel chocks	22
1.11 Mechanical support leg	22
2 MACHINE ASSEMBLY AT THE CUSTOMER	23
3 COMMISSIONING	23
3.1 Agregation to a tractor	24
3.2 Hydraulics connection	25
3.2.1 Setting the tractor flow rate	26
3.3 Machine folding and unfolding	27
4 MACHINE TRANSPORT ON ROADS	33
4.1 Sharp machine projection	34
5 MACHINE ADJUSTMENT	35
5.1 Machine working depth adjustment	35
5.2 Washers on the drawbar	36
5.3 Setting the front equipment	37
5.3.1 Setting the cutting cylinder lock Flexi-cut	37
5.4 Setting side deflectors	38
5.5 Setting edge discs	39
5.6 Setting the cutting disc	40
5.7 Turning at headland	40
5.7.1 Turning on rollers	41
5.7.2 Turning on the axle	41
5.8 Working span	42
5.9 Machine travelling direction at work	43
6 ELECTRONIC HYDRAULIC CIRCUIT SWITCH	44
6.1 Description of the equipment	44
6.2 System wiring diagram	44
6.2.1 Designation of system components	44
6.2.2 Wiring diagram	45
6.3 Main components	46
6.3.1 Controller	46
6.3.2 Hydraulic block	46
6.3.3 Power supply	47
6.4 Functions + pictograms	47
6.5 Connecting procedure	48
6.6 Emergency state	48
7 ADJUSTMENT AND MAINTENANCE PROCEDURES	49
7.1 Setting the hose mount	49

7.2	Depth connecting rods for the front row	49
7.3	Tracing wheel position.....	50
7.4	Roller positions	50
7.5	End stroke valve	51
7.6	Side frame stoppers.....	51
7.7	Towing lug wear check	52
7.8	Air jet drainage	53
8	TROUBLESHOOTING	54
8.1	Unfolding and folding	54
8.2	Field work	55
9	MACHINE MAINTENANCE AND REPAIRS	56
9.1	Replacement of the working roller bearings	57
9.1.1	Using the tool for bearing disassembly and assembly.....	58
9.1.1.1	Complete bearing disassembly	59
9.1.1.2	Disassembly of the ring.....	60
9.1.1.3	Assembling bearings onto pins	61
9.1.2	Using spacer.....	62
9.2	Maintenance plan.....	63
10	MACHINE STORAGE	66
11	MACHINE LUBRICATION SCHEDULE	66
12	ENVIRONMENTAL PROTECTION	67
13	MACHINE DISPOSAL AFTER SERVICE LIFE EXPIRY	67
14	SERVICING AND WARRANTY CONDITIONS	67
14.1	Servicing	67
14.2	Warranty.....	67

MACHINE LIMIT PARAMETERS

- The machine is designed for soil ploughing up to a depth of 13cm (5.12 in) when agricultural soil cultivation. Another type of use exceeding the determined purpose is forbidden.
- The machine is only operated by one person – the tractor driver.
- Machine operator must not use the machine in a different way, especially:
 - Transport of persons and animals on the machine structure,
 - Transport of burdens on the machine structure,
 - Aggregation of the machine with another towing equipment than stated in Chapter „3.1.“.

TECHNICAL PARAMETERS

Table 2 – Technical Parameters

PARAMETERS		SF800PRO	SF700PRO	SF600PRO	SF500PRO
Working width		7,56 m (24.8 ft)	6,85 m (22.5 ft)	5,9 m (19.4 ft)	4,93 m (16.2 ft)
Transport width		3 m (9,8 ft)			
Transport height		4 m (13.1 ft)	3,66 m (12.0 ft)	3,18 m (10.4 ft)	2,7 m (8.9 ft)
Machine total length		7,3 m (26.25 ft)			
Working depth		3,5–13 cm (1.38- 5.12 in)			
Number of discs Ø 530 mm (Ø21 in)	front	32	28	25	21
	rear	31	27	24	20
Working performance		7,5–11,3 ha/h (18-28 ac/h)	6,7–10,0 ha/h (17-26 ac/h)	5,7–8,6 ha/h (15-22 ac/h)	4,8–7,2 ha/h (12-18 ac/h)
Towing means		200–300 kW (270–405 HP)*	175–260 kW (240– 360 HP)*	150–225 kW (200–300 HP)*	130–190 kW (175–255 HP)*
Working speed		10–15 km/h (6 – 9.5 mph)			
Maximum transport speed		30 km/h (18.6 mph)			
Maximum slope grade		6°			
Tyre dimensions - transport	Tyre pressure	19.0/45-17 14PR 400/60-15,5 14PR	280 kPa 360 kPa***	19.0/45-17 14PR	280 kPa***
	Tyre pressure	31x15,50-15 10,0/75-15,3 14PR	300 kPa 550 kPa	31x15,50-15	300 kPa
Weight of machine		8 200 kg (18 100 lb) **	7300 kg (16 100 lb) **	6400 kg (14 100 lb) **	5600 kg (12 300 lb) **

* Recommended towing means, the real towing force may significantly vary according to the processing depth, soil conditions, land slope, working body wear and adjustment.

** Weight with the SDR roller

*** Pressure for BTK tyres; pressure may differ according to the tyre manufacturer

SAFETY STATEMENT



This warning sign warns about an immediate dangerous situation ending with death or severe injury .



This warning sign warns about a dangerous situation ending with death or severe injury .



This warning sign warns about a situation that may end with a smaller or slight injury. It also warns about dangerous actions related to the activity that could lead to an injury .

A. GENERAL INSTRUCTIONS FOR USE

- The machine is made in accordance with the latest equipment state and approved safety regulations. However, dangers of user or third person injury or machine damage or creation of other material damage may arise during use.
- Use the machine only in a technically sound condition, in accordance with its purpose, aware of possible dangers, and while adhering to the safety instructions of this operating manual! The manufacturer is not liable for damages caused by the use of the machine that is in contradiction with the limit parameters of the machine (p. 4) and with the instructions for the use of the machine (Chapter A and 3). The user bears the risk. Immediately remove especially the failures that may negatively affect safety!
- Machine operation may be performed by a person authorised by the operator under these conditions:
 - It must own a valid driver's licence of the corresponding category,
 - It must be demonstrably familiarised with the safety regulations for work with the machine and must practically master the machine operation,
 - The machine may not be operated by juveniles,
 - It must know the meaning of the safety signs located on the machine. Their respecting is important for safe and reliable machine operation.
- Maintenance and servicing repairs on the machine may only be performed by a person:
 - Authorised by the operator,
 - Educated in the machinery field with knowledge of repairs of similar machines,
 - Demonstrably familiarised with safety regulations for work with the machine,
 - During a repair of a machine connected to a tractor, it must own a driver's licence of the corresponding category.
- Machine operator must secure the safety of other persons when working with the machine or transporting the machine.
- During machine work in the field or during transport, the operator must control the machine from the tractor's cabin.
- The operator may enter the machine structure only with the machine at rest and blocked against movement, namely only for these reasons:
 - Adjustment of the machine working parts,
 - Repair and maintenance of the machine,
 - Release and securing of spherical valves of the axle,
 - Securing of spherical valves of the axle before folding the side frames,
 - Adjustment of the working parts of the machine after unfolding the side frames.
- When climbing on the machine, do not step on the axle tyres, rollers, discs or other revolving parts. Those may turn and you can cause very serious injuries by the subsequent fall.
- Any changes or modifications of machine may be performed only with written consent of the manufacturer. For possible damage arisen due to ignoring this instruction, the producer bears no responsibility. The machine must be maintained equipped with prescribed accessories and equipment including safety marking. All warning and safety signs must be legible and in their places. In case of damage or loss, these signs must be immediately renewed.
- The operator must have the Operating Manual with the work safety requirements available at any time when working with the machine.
- The operator must not consume alcohol, medicines, narcotic and hallucinogenic substances that decrease his attention and coordination capabilities while using the machine. If the operator must use medicines prescribed by a physician or uses freely sold medicines, he must be informed by a physician, whether he is capable of responsible and safe operation of the machine under these circumstances.



PROTECTIVE TOOLS

For the operation and maintenance use:

- Tight clothes
- Protective gloves and goggles for protection against dust and sharp parts of the machine



B. MACHINE TRANSPORT USING TRANSPORT MEANS

- B.1** The transport means designed for machine transport must have the load capacity minimally identical with the weight of the transported machine. The total weight of the machine is stated on the production label.
- B.2** ⁽²⁾ The dimensions of the transported machine including the transport means must comply with the valid regulations for road traffic (decrees, laws).
- B.3** ⁽³⁾ The transported machine must be always fastened to the transport means so that its spontaneous loosening could not happen.
- B.4** ⁽⁴⁾ The carrier is responsible for damage caused by the loosening of incorrectly or insufficiently fastened machine to the transport means.

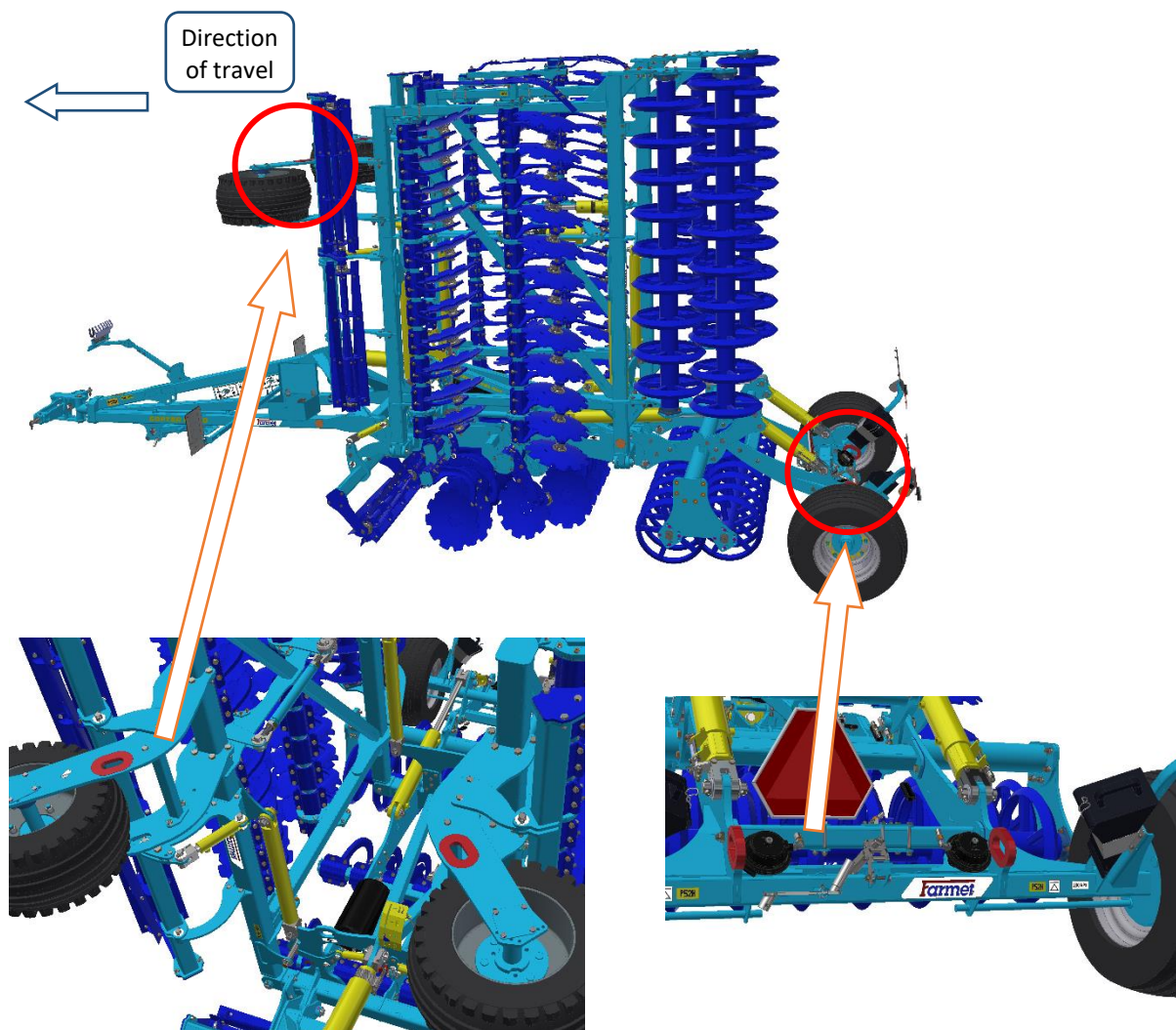

C. MACHINE HANDLING USING LIFTING EQUIPMENT



- C.1 The lifting equipment and tying means designed for handling of the machine must have their load capacity at least identical with the weight of the handled machine.
- C.2 Machine fastening for handling may only be performed in places designed for that and marked with self-adhesive labels showing the "chain" symbol 
- C.3 After fastening (suspending) at designated points, it is forbidden to move in the space of possible reach of the handled machine.

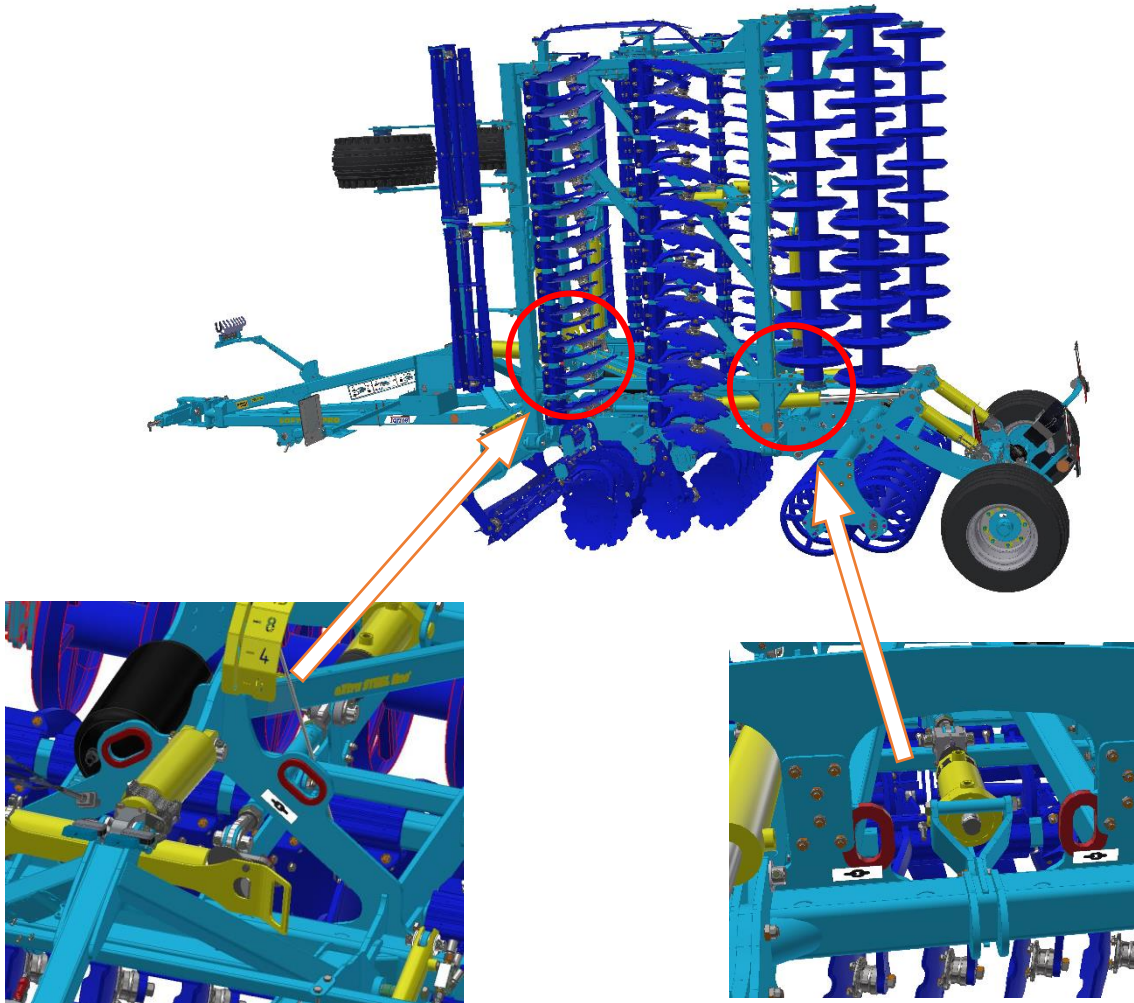

D. WORK SAFETY LABELS

Warning safety labels serve for operator protection.

General:





A) Strictly observe the warning safety labels.

B) All safety instructions also apply to other users.

C) Upon damage or destruction of the aforementioned "SAFETY LABEL" located on the machine, THE OPERATOR IS OBLIGED TO REPLACE IT WITH A NEW ONE!!!



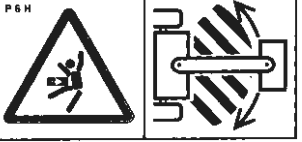

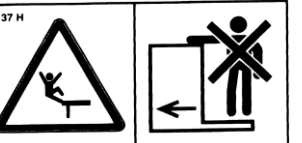
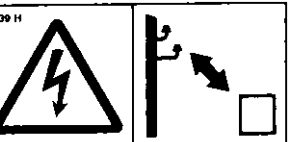
The position, appearance, and precise meaning of work safety labels on the machine is determined in the following tables (Table 3, 4) and in the picture (2).

Table 3– Self-adhesive warning safety labels located on the machine

WARNING SAFETY LABEL	LABEL TEXT	MACHINE POSITION
	<p>Before handling the machine, carefully read the operating manual. Observe the instructions and safety regulations for machine operation during use.</p>	P 1 H
	<p>When connecting or disconnecting, do not step between the tractor and the machine, also do not enter this space, if the tractor and the machine are not at rest and the engine is not turned off.</p>	P 2 H
	<p>Stay outside the reach of the tractor - agricultural machine set, if the tractor engine is in operation.</p>	P 6 H
	<p>Before commencing the machine transport, secure the axle with spherical valves against unexpected drop.</p>	P 13 H
	<p>When folding the side frames, do not reach into the space of the machine folding joints. There is a danger of cutting when setting the depth of the machine.</p>	P 20 H
	<p>Travelling and transport on the machine structure is strictly forbidden.</p>	P 37 H
	<p>When working and transporting the machine, maintain safe distance from the electric appliances.</p>	P 39 H

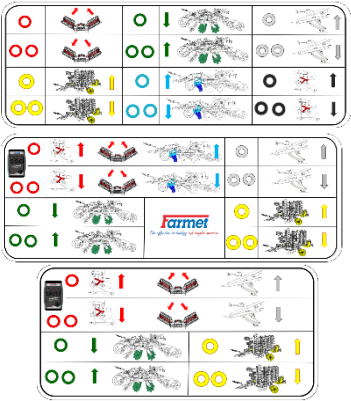
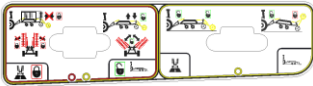
	<p>The pressure vessel is under gas and oil pressure. Execute disassembly and repairs only according to the instructions in the manual.</p>	<p>P 42 H</p>
	<p>When folding and unfolding the side frames, stay outside their reach.</p>	<p>P 50 H</p>
	<p>Secure the machine against unwanted movement.</p>	<p>P 52 H</p>
	<p>Do not approach the rotary parts of the machine, if these are not at rest, i.e. they do not turn.</p>	<p>P 53 H</p>
	<p>It is strictly folding and unfolding the side frames on slopes or inclined surfaces.</p>	<p>P 100 H</p>
	<p>The shown positions of the lever and the function of the hydraulic spherical valve located on the piston rod.</p>	<p>P 101 H</p>

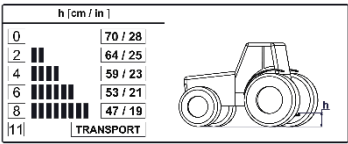
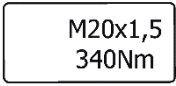
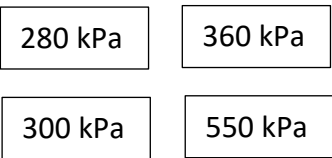
Table 4 Information Labels

POSITION NUMBER	LABEL	TEXT														
1		Designation of the hydraulic circuits and their functions														
2		Valve control panel														
3		Yellow circuit in the floating position (tracing the drawbar)														
4	 <table border="1" data-bbox="386 1160 550 1303"> <thead> <tr> <th colspan="2">h [cm / in]</th> </tr> </thead> <tbody> <tr> <td>0</td> <td>70 / 28</td> </tr> <tr> <td>2</td> <td>64 / 25</td> </tr> <tr> <td>4</td> <td>59 / 23</td> </tr> <tr> <td>6</td> <td>53 / 21</td> </tr> <tr> <td>8</td> <td>47 / 19</td> </tr> <tr> <td>11</td> <td>TRANSPORT</td> </tr> </tbody> </table>	h [cm / in]		0	70 / 28	2	64 / 25	4	59 / 23	6	53 / 21	8	47 / 19	11	TRANSPORT	Setting the drawbar washers according to the tractor hitch height
h [cm / in]																
0	70 / 28															
2	64 / 25															
4	59 / 23															
6	53 / 21															
8	47 / 19															
11	TRANSPORT															
5		Transport axle wheels/tracing wheels torque														
6		Recommended tyre pressure for the transport axle/tracing wheels														
7		Maximum slope grade														

Picture 2 – Location of safety labels on the machine SOFTER PRO

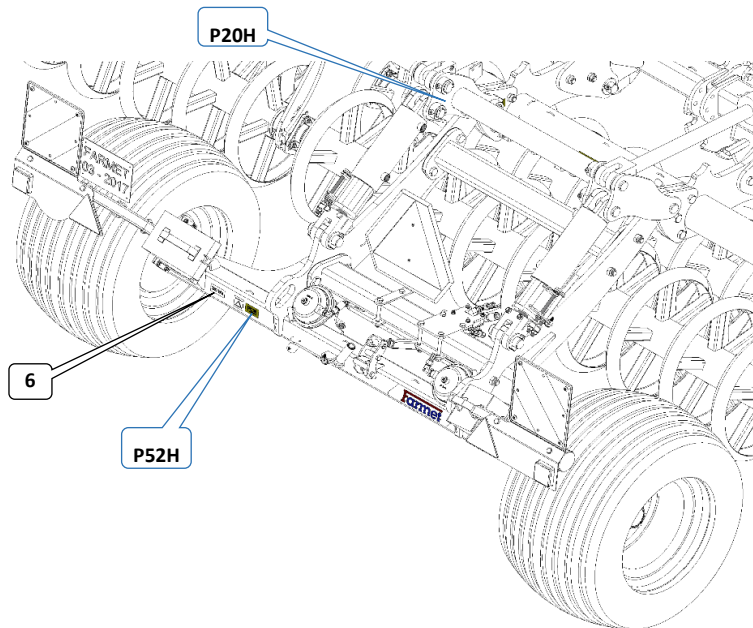
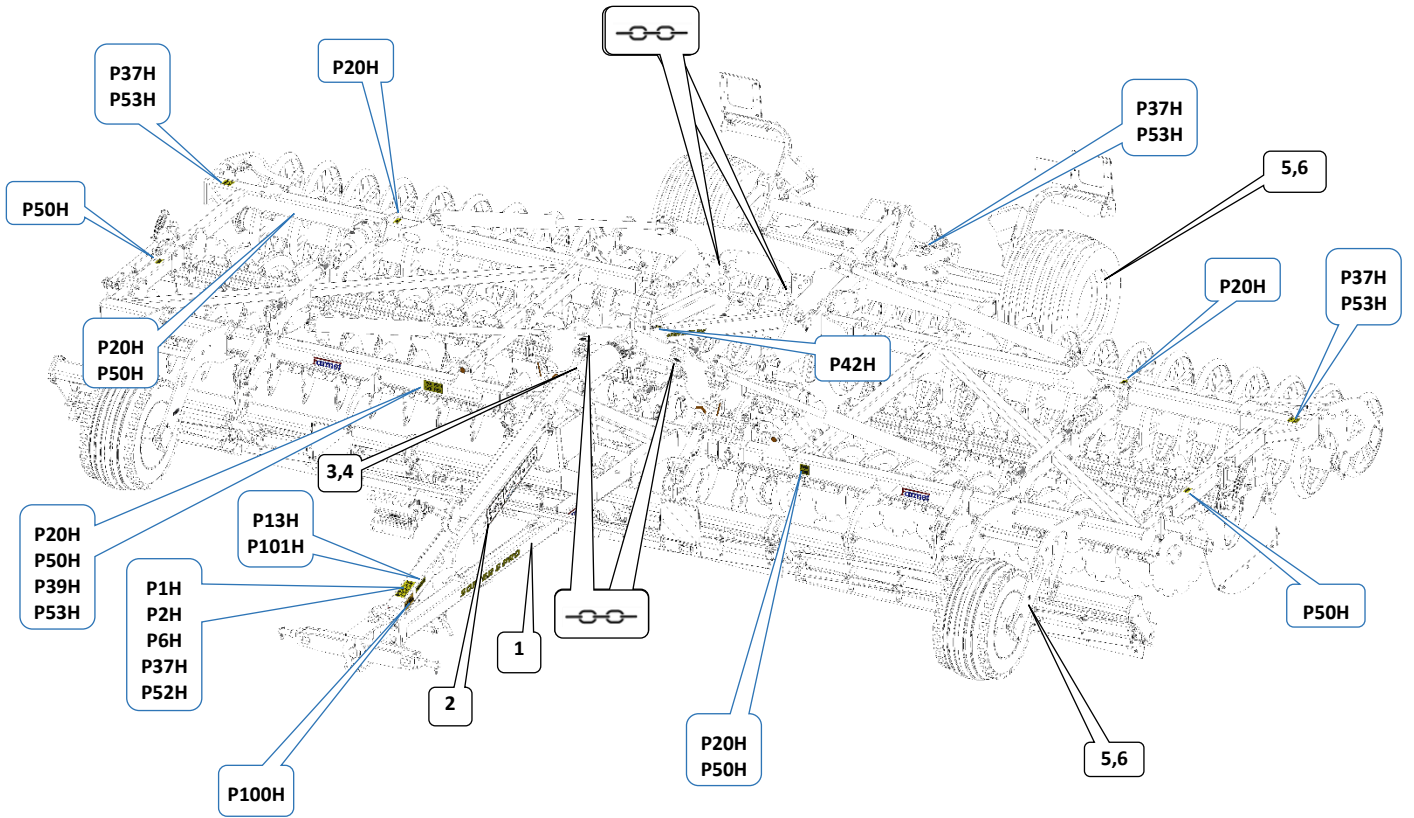

1 DESCRIPTION

The **SOFTER PRO** machine is constructed as semi-carried. The basic version consists of a drawbar equipped with a loop for the fixed suspension pin or carrier bar for TBZ, a central frame with the transportation axle two side frames. There are working discs in two rows on the central and side frames. There are rollers in the rear that compact the loosened soil.

1.1 WORKING PARTS OF THE MACHINE

Picture 3– Work Parts of the Machine

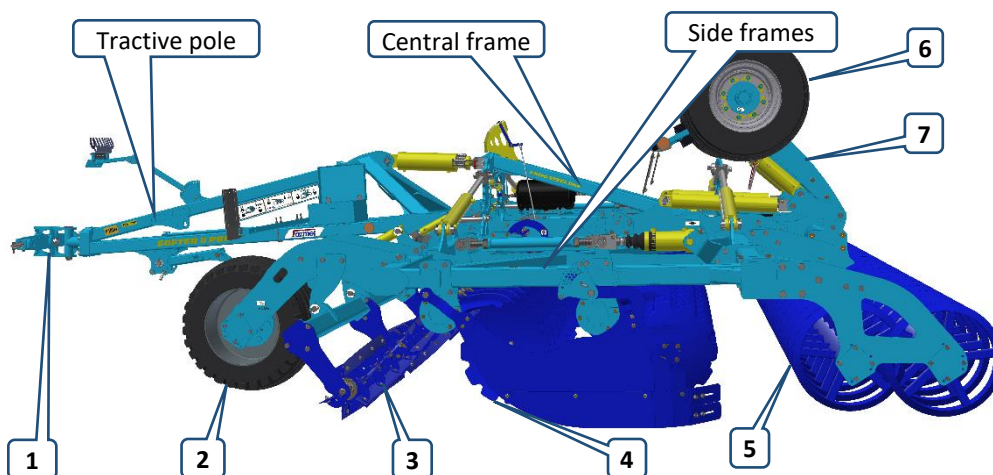

1	Tractive pole with a folding leg
2	Supporting wheel
3	Front equipment
4	2 rows of discs
5	Roller
6	Transportation axle
7	Wheel chocks

1.2 HYDRAULIC VALVE FUNCTION

- There are three levers that control the closing and two-way valves on the SOFTER PRO machine.
- The panel is located on the left side of the drawbar (Picture 3)



Attention! The machine may move suddenly when some of the valves are changed over.

Safety axle lock and folding

	<p>Locking for transport</p> <p>The red (folding) and yellow (axle) circuits are closed. The circuits cannot be moved. Lever position – on the left.</p> <p>Used for transport.</p>
	<p>Field work</p> <p>The red (folding) and yellow (axle) circuits are open. Lever position – on the right.</p> <p>Used for work.</p> <p> Attention! The machine may move suddenly when changed over.</p>

Turning at headland

- Used to lock the axle for turn at headland
- The machine moves only on the roller when working in the field

	<p>Transport</p> <p>The yellow circuit is used to move the drawbar, axle and central roller. It is used for conversion between the working and transport position of the transport axle and the middle roller. Used for transport and folding. The circuit can also be used for work with turning on the axle.</p>
	<p>Field work</p> <p>Axle and middle roller are locked. The machine only lifts on the drawbar. Lever position – on the right. Used at work.</p>

1.3 HYDRAULIC DIAGRAM OF THE MACHINE

Folding, axle, disc depth, flexible leveller (by equipment)

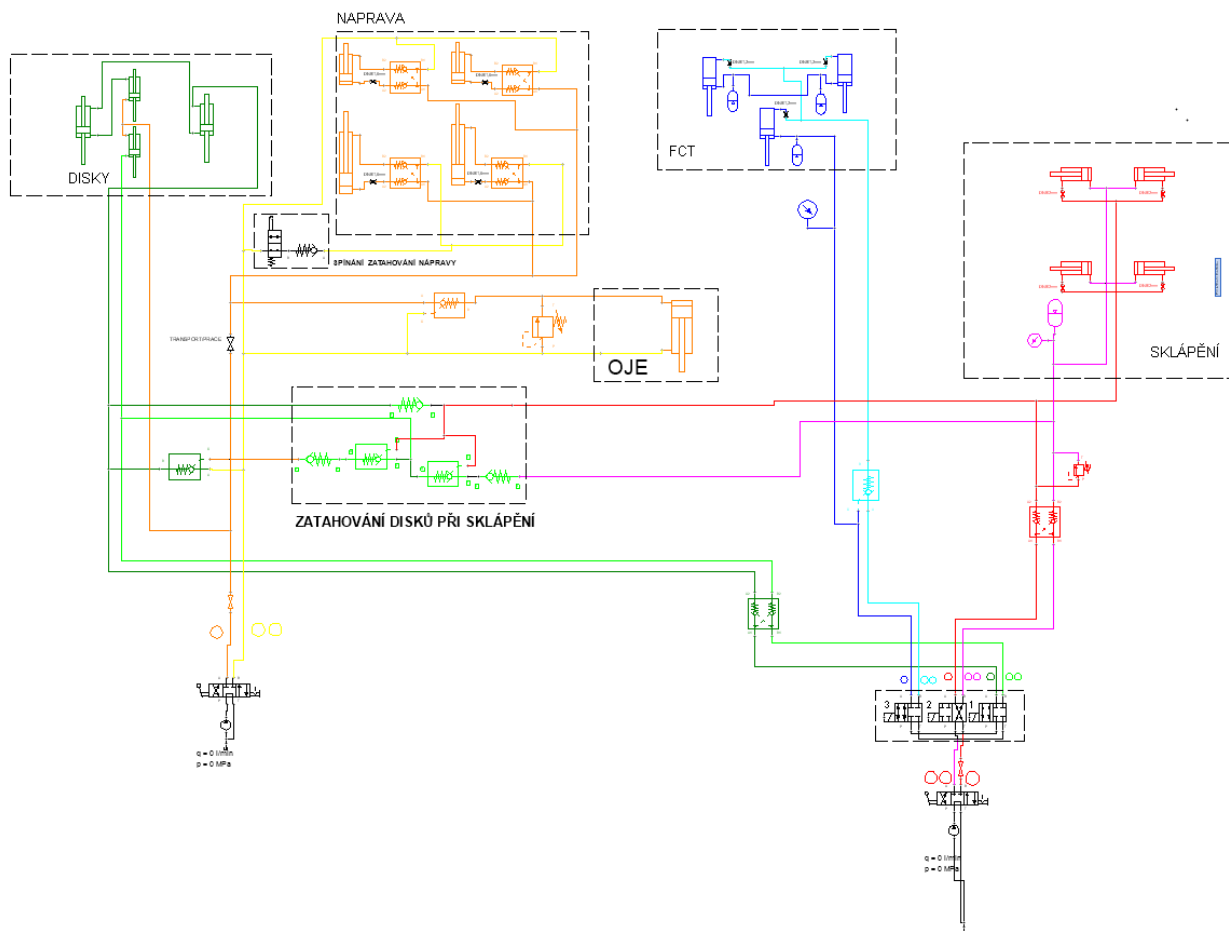

1	Side and edge frame folding	Red circuit
2	Hooks to secure frames for transport	Black circuit
3	Axle – short piston rod	Yellow circuit
4	Axle – long piston rod	Yellow circuit
5	Drawbar	Yellow circuit
6	Setting the disc depth	Green circuit
7	Flexible leveller / Flexi cut	Blue circuit
8	Hydrotronic	
9	Tractor switchboards	

1.4 BRAKE DISTRIBUTION OF THE MACHINE

- The standard version of the machine includes a single-circuit two-line braking system by KNORR BREMSE.
- Braking is provided by pneumatic brake cylinders.
- The parking brake is mechanical, controlled by a jack on the axle.
- Always check that the parking and operating brakes are released prior to driving.
- If the machine is equipped with brakes, they must be connected to the tractor when driving.
- Always release the brakes of the machine when lifting the machine on the axle.

1.4.1 Brake distribution diagram

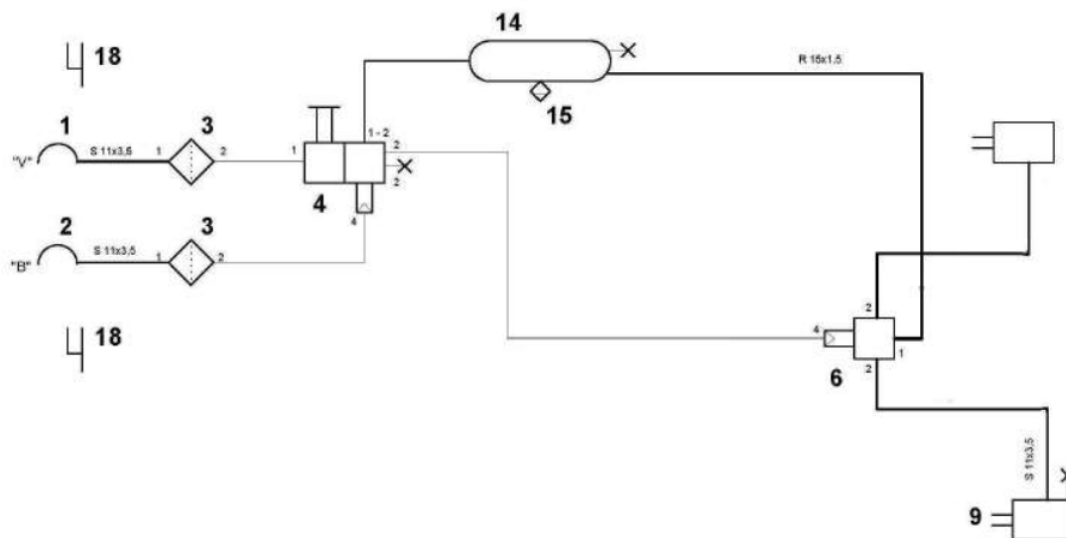

1	Quick-coupler – red line
2	Quick-coupler – yellow line
3	Air filter
4	Trailer switchgear
6	Relay valve
9	Membrane brake cylinder Type 16"
14	Air tank 20 l
15	Bleeding valve
18	Quick-coupler – red line

1.4.2 Hand brake control valve

The manual brake is controlled with a jack and a lever on the axle. When engaging and releasing the brake, always turn the jack to the end stop. The parking brake is only functional when the step of the brake levers on both wheels is correctly adjusted.

Attention! When air brakes are used, the parking brake jack must be released all the way. If the jack is not released all the way, it might continue braking slightly when the air brakes are released.

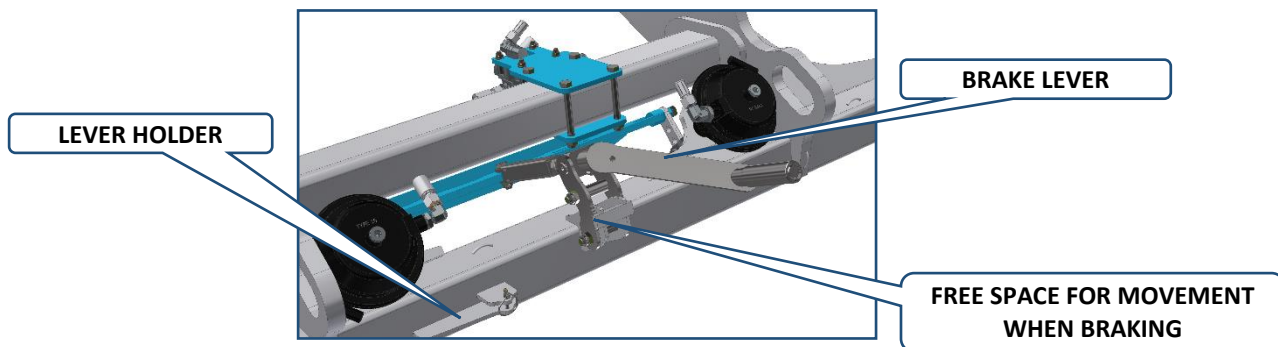

1.4.3 Emergency pneumatic brake control

- The emergency brake is automatically activated when air brakes are disconnected
- The activation only happens when there is sufficient pressure in the air tank
- You can use the black button on the brake switchboard to release brakes for manipulation
- When the system is pressurized, it automatically switches to the driving (extended) position

Black button extended

- The emergency brake is engaged

Black button pressed

- The emergency brake is released

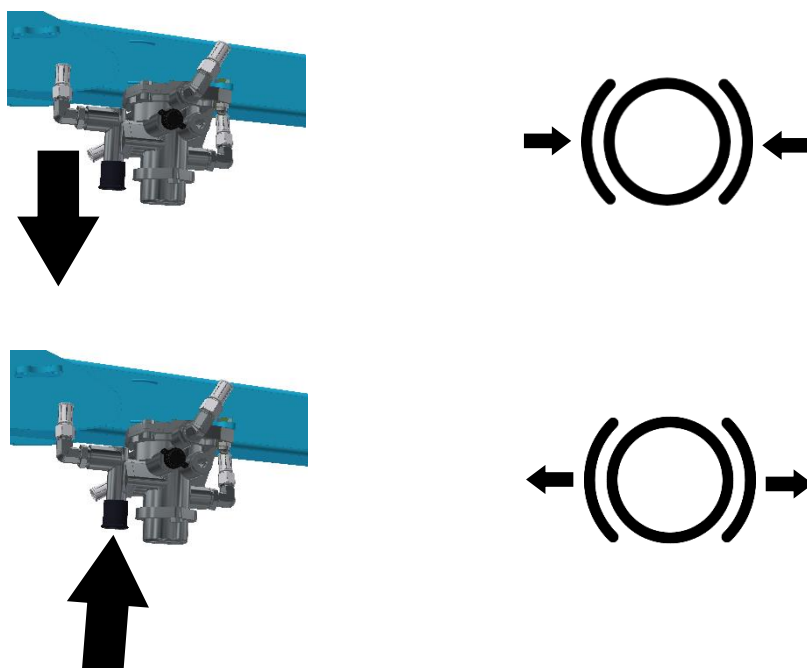

1.5 LIGHTING EQUIPMENT

- The electric system is designed for direct-current power supply at 12V.
- The lighting equipment has to be activated when driving on roads.
- The trailer plug connection is shown in the table (Table 6)
- The system is made of LED lights, it does not need any maintenance.
- The circuits of the indicators include connected resistances (KR, KL) for proper indication of the function in the tractor.

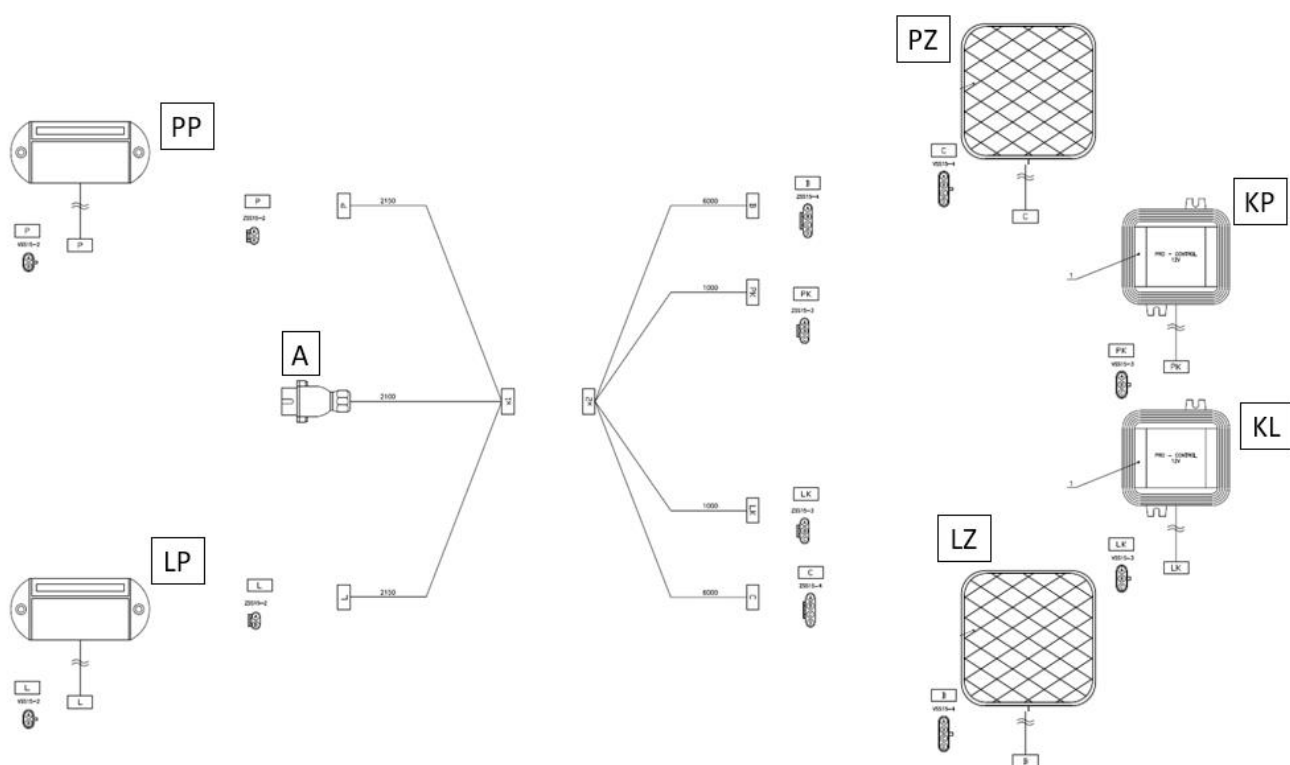

SYMBOL	DESCRIPTION
A	7-pin plug (ISO 1724)
LP	Left front headlight
PP	Right front headlight
KL	Left "controller"
KP	Right "controller"
LZ	Left taillight
PZ	Right taillight

Table 6 Connection of the 7-pin plug on the machine

No	SYMBOL	FUNCTION
1	L	Left indicator
2	54G	Rear fog light
3	31	Earthing
4	R	Right indicator
5	58R	Left taillight
6	54	Brake light
7	58L	Right taillight



1.6 HYDRAULIC FRAME LOCK (SF800PRO, SF700PRO)

- The machine is equipped with a hydraulic system for locking the side frames during transport
- The hooks prevent unintentional unfolding, or unfolding due to external forces, or due to a broken hose of side frame folding
- The control is functional after it is changed over by the red circuit from the tractor cabin
- Top position – locked
- Bottom position – unlocked
- Always check that the hooks are properly locked before driving on roads
- When driving on roads, the red circuit has to be closed with the valve
- Before unfolding, release the hooks by changing them to the bottom end position
- Before folding, check that the hooks are in the bottom position

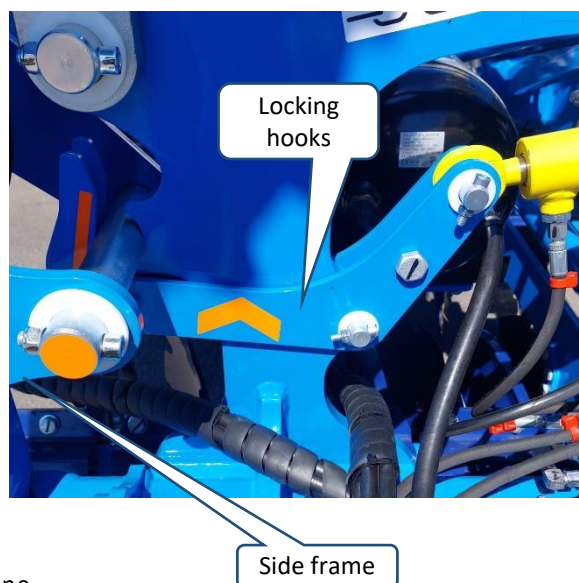

1.7 MECHANICAL FRAME LOCK (SF600PRO, SF500PRO)

- The machine is equipped with mechanical side frame lock for transport
- The rod prevents accidental unfolding or unfolding due to external forces or rupture of the side frame folding hose.
- Always make sure that the rod is properly locked prior to driving on roads (the locking is automatic).
- When driving on roads, the red circuit must be closed with the valve.
- Prior to unfolding, release the locking rod by pulling the handle on the rod.
- Check that the rod is tilted so that the end of the piston rod pin is outside the opening of the rod.
- Prior to folding, check that the piston rod pin is not contaminated.
- The side frame end stops must be adjusted for proper function.

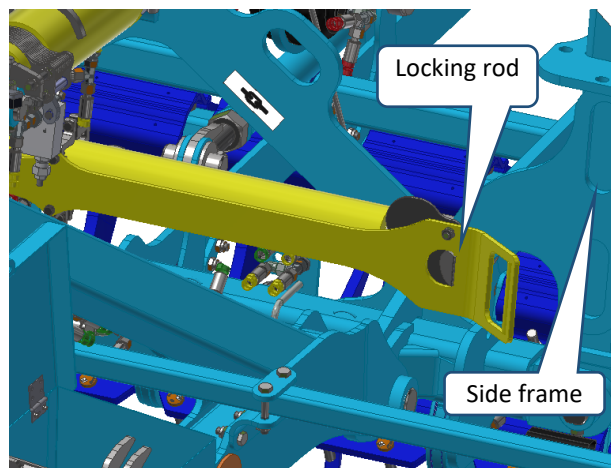

1.8 TRANSPORT RESTS ON THE AXLE

- The transport rests on the axle are used as a safety component when driving on roads
- When the machine is lowered down onto the rests, the transportation height of the machine is below 4m (13.1 ft) (SF800PRO)
- The rests also prevent the lowering of the machine in the case of damage to the hoses and the hydraulic lock

Secured the rests

- Used for transport, height of the machine below 4 m (13.1 ft)
- Hose burst protection

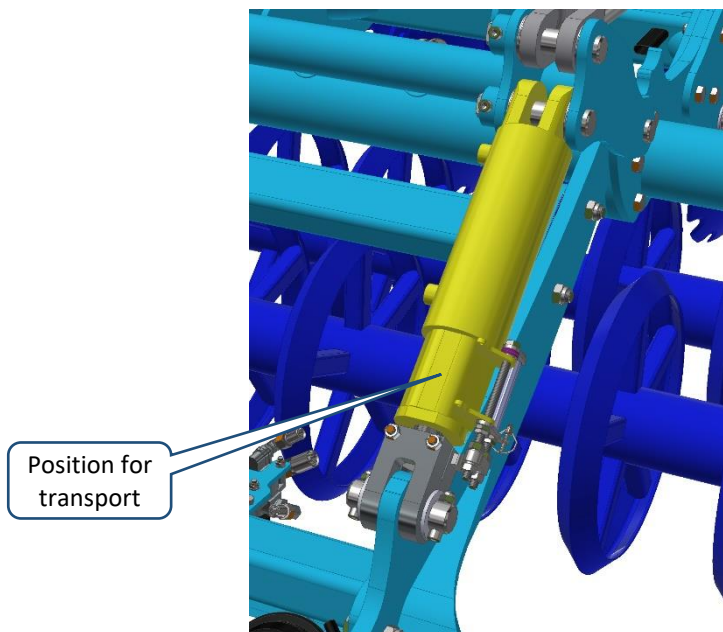

Working positions of the rests

- It is used for work and for free movement of axle in whole extent
- To secure the rest, use the safety pin with a ring

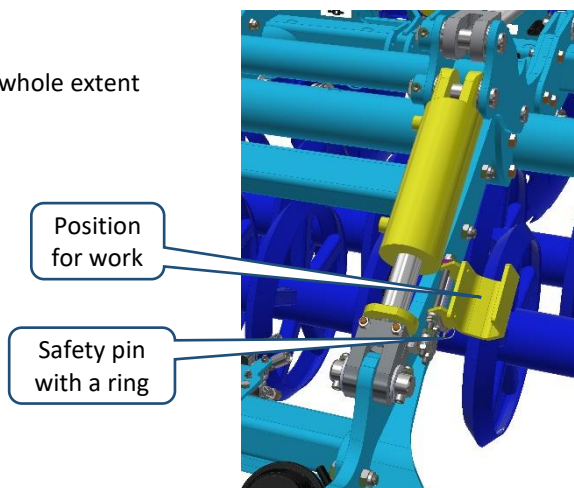

1.9 DEVICE AGAINST UNAUTHORIZED USE

- Each machine is supplied with a device against unauthorized use
- The device is used according to the hitch type as shown in the picture 6
- The device must be used whenever an unauthorized use of the machine is possible

Picture 6 Device against unauthorized use

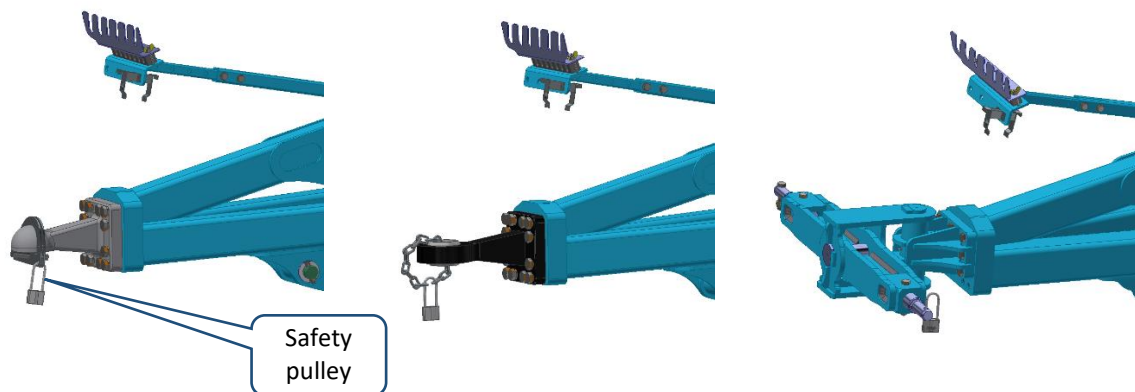

1.10 WHEEL CHOCKS

- The chocks for securing the machine are located on the drawbar
- The chocks shall be used when the machine is disconnected to block the transport axle wheels

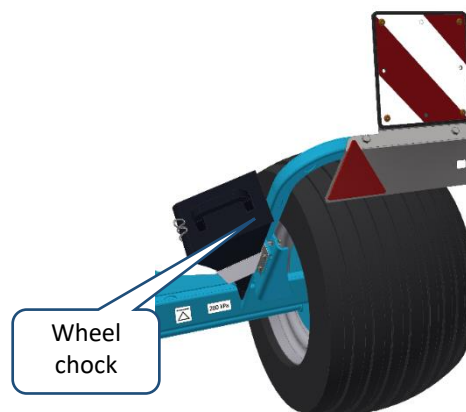

1.11 MECHANICAL SUPPORT LEG

- For the three-point hitch connection
- Use the pin positions marked in the figure for transport and parking
- The machine can be equipped with a hydraulic leg on request

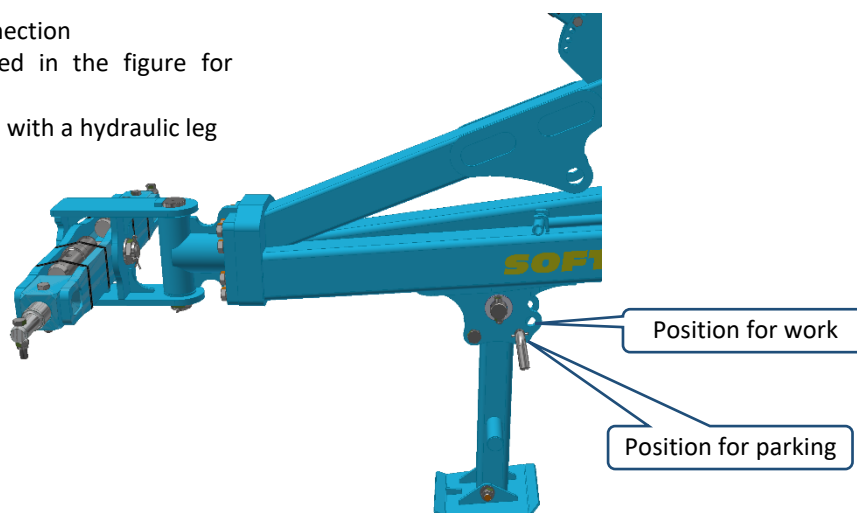

2 MACHINE ASSEMBLY AT THE CUSTOMER



- The operator must perform the assembly according to the instructions of the producer, best in cooperation with the expert servicing technician determined by the producer.
- The operator must secure a functional test of all assembled parts after the completion of the machine assembly.
- The operator must secure that the handling of the machine using lifting equipment during its assembly is in accordance with chapter „C“.

3 COMMISSIONING



- Before taking over the machine, test and check, whether damage occurred during transport and whether all parts contained in the bill of delivery were supplied.
- Before commissioning the machine, carefully read this operating manual, especially Chapters **A-D** p. 7-13. Before the first use of the machine, familiarise yourselves with its controls and overall function.
- During work with the machine, observe not only the instructions of this operating manual but also generally valid regulations of work safety, health protection, fire and transport safety, and environmental protection.
- The operator must check the machine before every use (commissioning) from the standpoint of completeness, work safety, work hygiene, fire safety, transport safety, and environmental protection.
- A machine showing signs of damage must not be commissioned.
- Aggregation of the machine with the tractor is to be performed on a flat and hardened surface.
- When working on slopes, observe the lowest allowable slope grade of the set **TRACTOR - MACHINE**.
- Before starting the tractor motor, check whether no person or animal is in the working space of the set and push the warning sound signal.
- The operator is responsible for the safety and all damage caused by the operation of the tractor and the connected machine.
- The operator is obliged to adhere to the technical and safety regulations of the machine determined by the producer when working.
- When turning the machine at headland, the Operator must lift the machine, i.e. the working bodies are not in the ground.
- The operator is obliged to observe the prescribed working depths and speeds stated in the manual in Tab. 2/p. 5 when.
- The operator is obliged to lower the machine to the ground and secure the set against movement before leaving the tractor cabin.

3.1 AGREGATION TO A TRACTOR

- The machine can be connected only to a tractor, whose curb weight is identical or higher than the overall weight of the connected machine.
- The machine operator must observe all generally valid regulations of work safety, health protection, fire safety, and environmental protection.
- The operator may connect the machine exclusively to a tractor that is equipped with a rear three-point suspension (or bottom fixed suspension) and a functional undamaged hydraulic system.

Table 7– The table of requirements for the towing means for work with the machine

Requirement for the tractor engine power for disc plough-harrow		SF800PRO	200-300 kW (270-405 HP)
		SF700PRO	175-260 kW (240-360 HP)
		SF600PRO	150-225 kW (200-300 HP)
		SF500PRO	130-190 kW (175-255 HP)
Requirement for tractor aggregation	Beam TBZ	Hinge category	3-4
		Suspension joint spacing (measured in joint axes)	1010±1,5 mm (39.76 in)
		Diameter of the hole of the suspension joints for the suspension pins of the machine	Ø37,5 mm (Ø1.48 in)
	Fixed suspension	Height of the lower fixed hinge	500 – 600 mm (19.7 – 23.6 in)
		Mechanism of the aggregation of the bottom fixed suspension	Pin Ø 50mm (1.96 in)
			Pin Ø 70mm (2.75 in)
Requirement for the tractor's hydraulic system		Side frame folding circuit	Circuit pressure 200 bar (2900Psi), 2 pcs of quick-coupler sockets ISO 12,5
		Axle lifting circuit	
		Disc lifting circuit	
		Frame locking circuit	
		Front equipment lifting circuit	
		Support leg circuit	

- Connect the machine to the fixed bottom hitch and secure it against disconnection.
- If the drawbar of the machine is equipped with a safety chain, attach it to the tractor.



When connecting, no persons may stay in the space between the tractor and the machine.

HYDRAULIC OIL SPECIFICATIONS

The hydraulic circuit of the machine is filled with oil at the factory:

Performance level: API GL 5; SAE 10W-30; SAE 80

Manufacturer's specification: ALLISON C4; CATERPILLAR TO-4; VOLVO VCE WB 101; 97303 JONH DEERE 20C/20D ZF TE-ML 03E/05F/06E/06F/06K/17E/21F; PARKER

DENISON HF-0/HF-1/HF-2 New HOLLAND NH 420A/410B MASSEY FERGUSON M1135/M1141/M1143/ M1145 KUBOTA UDT Fluid CASE IH MS-1204/MS-

1206/ MS-1207/MS-1209 FORD M2C134D M2C86B/C CNH MAT 3525/ MAT3526 SPERRY VICKERS/EATON M2950S, I-280-S SAUER

SUNDSTRAND(DANFOSS) Hydro Static Trans fluid; CASE CNH MAT 3540(CVT), Claas(CVT), AGCO CVT; ML200, Valtra G2-10(XT-60+)

3.2 HYDRAULICS CONNECTION

- Connect the hydraulics only when the hydraulic circuits of the machine and the tractor (aggregate) are in a pressure-less condition.
- The hydraulic system is under high pressure. Regularly check for leaks and immediately remove obvious damage of all lines, hoses, and pipe unions.
- When seeking and removing leaks, use only the suitable tools.
- For connecting the hydraulic system of the machine to the tractor, use the plug (on the machine) and the socket (on the tractor) of the quick-couplers of the same type.
- Connect the quick-couplers of the machine to the tractor's hydraulic circuits so that one hydraulic circuit in the machine is connected to one circuit in the tractor (double-acting hydraulic circuits).



In order to prevent accidental or foreign person (children, passengers) caused movement of the hydraulics, the control switchboards on the tractor must be secured or blocked in the transport position.

Picture 7 Hydraulic Circuits

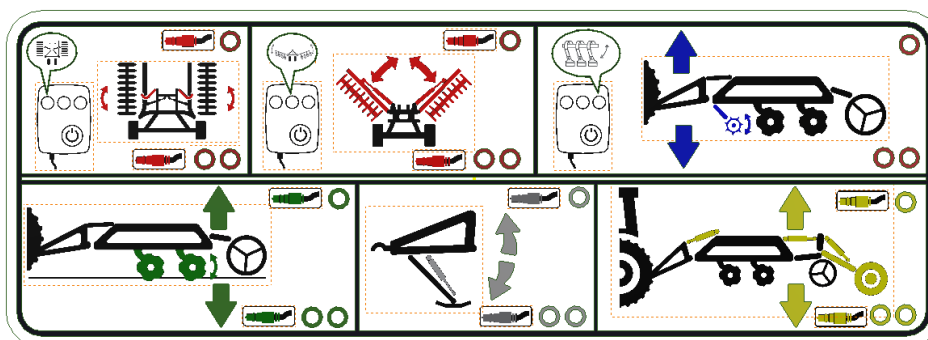

RED CIRCUIT – control of side frames folding

- **1 TAPE** folding side frames into the transport position
- **2 TAPES** unfolding side frames into the work position

BLACK CIRCUIT – control of the locking hooks of the side frames

- **1 TAPE** securing the folded side frames with hooks
- **2 TAPES** unlocking the hooks of the side frames

YELLOW CIRCUIT – lifting the machine into the transport position and when turning

- it must be in the floating position during operation to ensure drawbar tracing
- **1 TAPE** lifting the machine on the axle and drawbar
- **2 TAPES** lowering the machine on the axle and drawbar

GREEN CIRCUIT – control of the disc working depth

- **1 TAPE** lowering discs to the ground => increasing working depth
- **2 TAPES** lifting discs from the ground => decreasing working depth

BLUE CIRCUIT – control of the front equipment working depth

- **1 TAPE** lowering the front equipment to the ground => increasing working depth
- **2 TAPES** lifting the front equipment from the ground => decreasing working depth

WHITE CIRCUIT – control of the support leg of the drawbar

- **1 TAPE** lowering the support leg to the ground, increasing the drawbar height above ground
- **2 TAPES** lifting the support leg from the ground, decreasing the drawbar height above ground

- To reduce the number of circuits required in the tractor, it is possible to use an electronic hydraulic circuit switch. (Chapter 6)
- The circuit breaker combines the red, black and blue circuits into one circuit, red.

3.2.1 Setting the tractor flow rate

- If the tractor permits, it is recommended to set the **maximum flow rate** into all external tractor hydraulic circuits
- The maximum flow rate ensures a continuous operation and the proper function of the flow restrictors and hydraulic locks
- The tractor hydraulics automatically reduces the pump flow rate according to the actual need



PRESSURE VESSEL

Never open or adjust (welding, drilling etc.) the pressure vessel (pressure accumulator). The pressure vessel is still under gas pressure even after it has been emptied.

Empty the pressure vessel in case of any work on the hydraulics of the machine. The manometer must not show any pressure, or the pressure on the manometer must decrease to 0 bars. Only then it is permitted to work on the hydraulic circuit.

It is prohibited to disassemble the parts of the machine hydraulic system that are pressurized. Hydraulic oil that penetrates skin under high pressure causes serious injuries. Immediately seek medical attention in case of injury.

Picture 8 Work on the hydraulic circuit

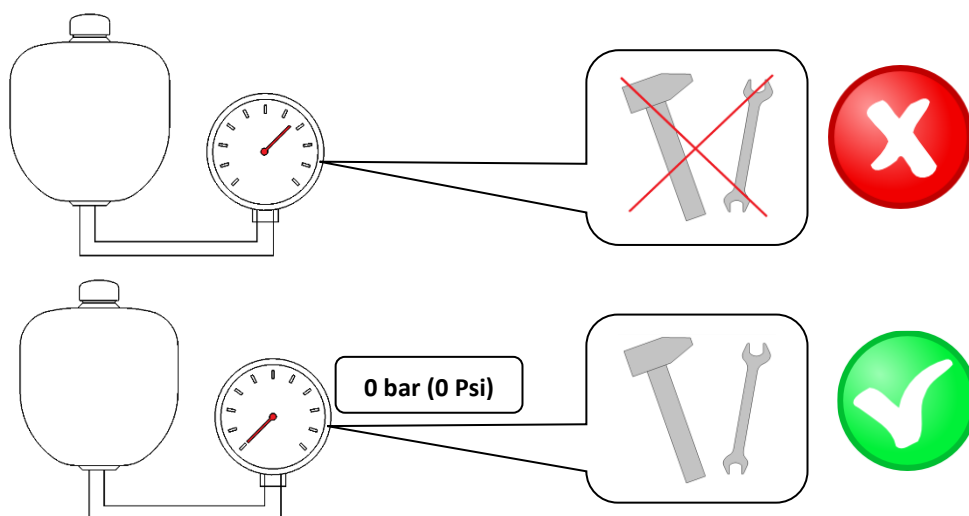

3.3 MACHINE FOLDING AND UNFOLDING



- The hydraulics for the folding and unfolding must be connected to the double-action control unit.
- The operator must ensure that during folding and unfolding of the side frames, no person or animal is within their reach (i.e. at the place of their impact) or vicinity.



- Perform folding and unfolding on flat and solid surfaces or laterally to the slope with the fully open control unit.
- Execute the folding or unfolding only with a machine that is raised on the axle.
- During folding or unfolding, check the side frames and have them continuously fold into the end position to the stoppers.

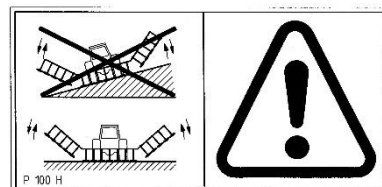

- **Remove stuck soil from folding points, soil may impair function and cause damage to the mechanics. Soil may also apply excessive load on the machine frames during folding and transport.**
- **Both frames must be in the limit position when unfolding; set the frame pressure to 80 bar.**
- **Set the deflector in the transport position prior to folding to reduce the machine height.**



AUTION!!! The machine must be lifted on the axle when the machine is folded and unfolded.

Picture 9 Position deflectors (SF800PRO)

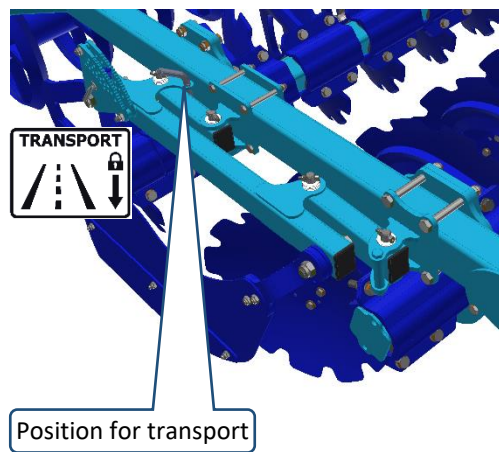
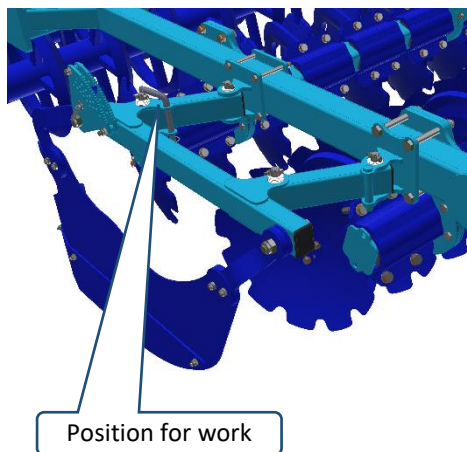

Picture 10 – Machine position for folding

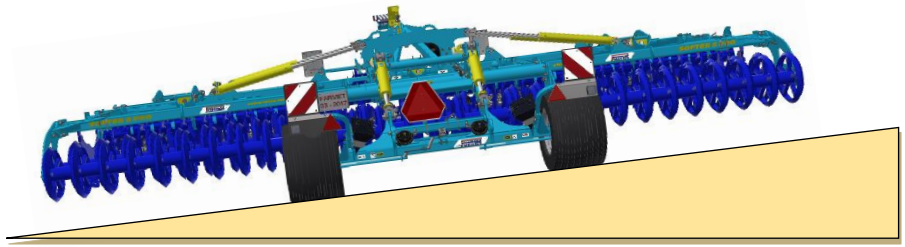
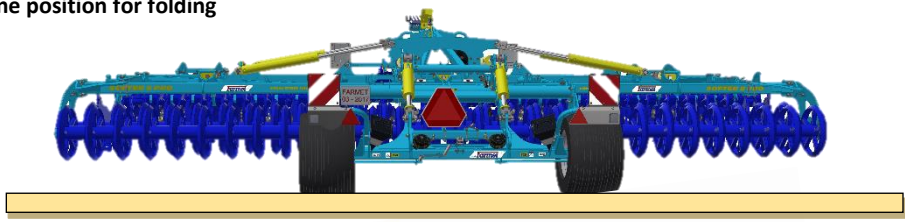

Picture 11 – Machine position for unfolding

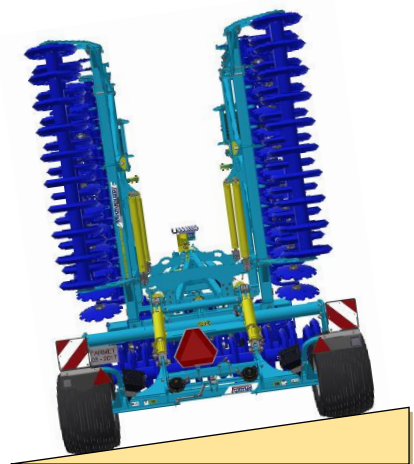

Machine unfolding procedure SF800PRO/ SF700PRO– work position

Initial condition: The machine is lifted on the axle (transport height of up to 4 m / 13.1 ft), the side frames are secured with a hook, both levers switched to the transport position

<p>1</p>		<p>Use the lever to open the valves of the axle and folding circuits.</p>
<p>← (P) →</p>		<p>Release the brakes. Lift the machine to the maximum height (yellow circuit).</p>
		<p>Set the required number of washers on the drawbar hydraulic cylinder (chapter 5.2). Tilt the axle piston rod end stops.</p>
<p>2</p>		<p>Release the locking hooks downwards.</p>
		<p>Unfold the machine, set pressure in the circuit at 80 bar (1160 Psi) (red circuit).</p>
<p>← (P) →</p>		<p>Release the brakes. Lift the axle to the working position.</p>
<p>3</p>		<p>Change the control lever of the shut-off valve to the work position. Set deflectors in the working position and height. The machine is prepared for work.</p>
<p>SETTING THE DOWN PRESSURE OF SIDE FRAMES</p> <ul style="list-style-type: none"> • When the machine has been unfolded, the down pressure of the side frames must be adjusted to ensure optimal terrain tracing. • Set the value of 80 bar (1160 Psi) on the pressure gauge using the circuit for unfolding. 		

Machine Folding Procedure SF800PRO/ SF700PRO – Transport Position

Initial condition: The machine is lifted for turning at headland, the locking hooks are in the bottom position

1		Set the right lever for the axle lock to the transport position.
		Set the deflectors into the transport position.
		Release the brakes. Lift the machine to the maximum height (yellow circuit).
		Fold the machine using the red circuit. The front equipment will automatically move to the minimum depth. The discs will automatically retract.
		Lift the locking hooks using the red (Hydrotronic) or black circuit.
2		Add all the rests to the drawbar piston rod. Move the transport rests in the secured position.
		Lower the machine onto the washers and the end stop (yellow circuit). Height below 4 m (13.1 ft). (SF800PRO) The central frame is in the horizontal position.
3		Change the left lever to the locked position (red and yellow circuits are closed).

Machine unfolding procedure SF600PRO/ SF500PRO– work position

Initial condition: The machine is lifted on the axle, the side frames are secured with a hook , both levers switched to the transport position.

<p>1</p>		<p>Use the lever to open the valves of the axle and folding circuits.</p>
<p>← (P) →</p>		<p>Release the brakes. Lift the machine to the maximum height (yellow circuit).</p>
		<p>Set the required number of washers on the drawbar hydraulic cylinder (chapter 5.2). Tilt the axle piston rod end stops.</p>
<p>2</p>		<p>Release the locking hooks.</p>
		<p>Unfold the machine, set pressure in the circuit at 80 bar (1160 Psi) (red circuit).</p>
<p>← (P) →</p>		<p>Release the brakes. Lift the axle to the working position.</p>
<p>3</p>		<p>Change the control lever of the shut-off valve to the work position. Set deflectors in the working position and height. The machine is prepared for work.</p>
<p>SETTING THE DOWN PRESSURE OF SIDE FRAMES</p> <ul style="list-style-type: none"> • When the machine has been unfolded, the down pressure of the side frames must be adjusted to ensure optimal terrain tracing. • Set the value of 80 bar (1160 Psi) on the pressure gauge using the circuit for unfolding. 		<p>80 bar (1160 Psi)</p>

Machine Folding Procedure SF600PRO/ SF500PRO – Transport Position

Initial condition: The machine is lifted for turning at headland

1		Set the right lever for the axle lock to the transport position.
		Set the deflectors to the transport position.
		Release the brakes. Lift the machine to the maximum height (yellow circuit).
		Fold the machine using the red circuit. The front equipment will automatically move to the minimum depth. Discs will automatically retract.
		Automatic frame lock check
2		Insert all the washers onto the drawbar piston rod.
		Lower the machine onto the washers and the end stop (yellow circuit). Height below 4 m (13.1 ft). The central frame is in the horizontal position.
3		Change the right lever to the locked position (red and yellow circuits are closed).

4 MACHINE TRANSPORT ON ROADS



Transport position of **SOFTER PRO**

- Connect the machine to the tractor by the fixed bottom hitch using a pin or a ball .
- Bring the machine into the transport position.
- The height must be lower than 4 metres (13.1 ft). The machine is lowered on the washers of the drawbar piston-rod and on the end stops of the axle. The central frame is in the horizontal position.
- The machine must be equipped with removable shields with marking of contours, functional lighting, and the board of the rear marking for slow vehicles (according to ECE No. 69).
- The lighting must be activated during travelling on roads.
- The tractor must be equipped with a special light device of an orange colour, which must be activated during travelling on roads.
- When the machine is equipped with a brake system, it has to be connected to the tractor when driving.
- The maximum transport speed during travelling on roads is **30 km/h (18.6 mph)**.



Ban of transport with decreased visibility!

- The operator is obliged to pay increased attention during transport on roads, due to the transport dimensions of the machine.
- The operator must observe the valid regulations for transport on roads (laws, decrees) after connecting the machine to the tractor, for reason of a change of the axle load. The driving properties of the set also change depending on the terrain nature, adapt the manner of driving to these conditions.
- Only machines with a valid technical certificate issued in accordance with the valid regulation on the approval of technical qualification and operation on public communications as amended may be transported on public communications. Machines without a valid technical certificate may only be transported on public communications when carried by a towed trailer or other approved means of transport in accordance with the valid regulation.
- The operator is obliged to secure sufficient outlook during reversing from his position of the tractor driver. In case of insufficient outlook, the operator is obliged to call a competent and informed person.
- The operator must fold the side frames for transport and secure them against unwanted unfolding by disconnecting the hydraulic circuit of the machine and the tractor.
- During machine transport on roads, the operator must observe the valid laws and decrees that deal with this topic and which specify the relationships of the tractor axle load depending on transport speed.
- Clean the entire machine from any accumulated soil before the transportation on the road.

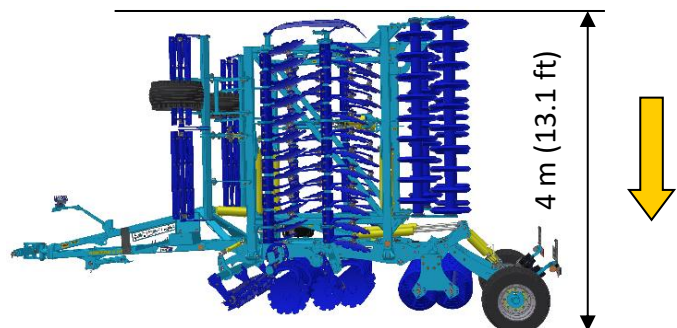
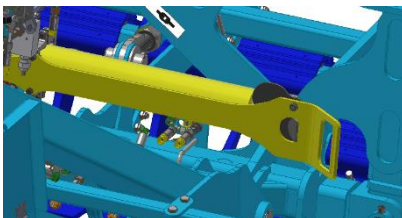

CHECKING THE NUTS ON THE TRANSPORT AXLE

- Use the plastic arrow “Check Point” to check for loose nuts. It promptly shows the condition of the nuts, whether they are loose or not.
- Always check the Check Points before driving.
- When the arrows are not facing one another, the nuts have to be tightened to the required torque and the Check Point arrows have to point against one another as shown in the green picture.

Torque for the axle nuts:

M18x1,5 - 265Nm

M20x1,5 - 343Nm

M22x1,5 - 440Nm

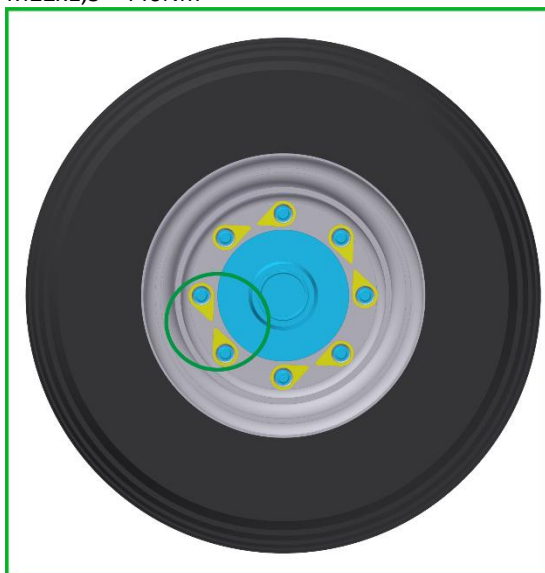

INITIAL POINT-TO-POINT CONFIGURATION

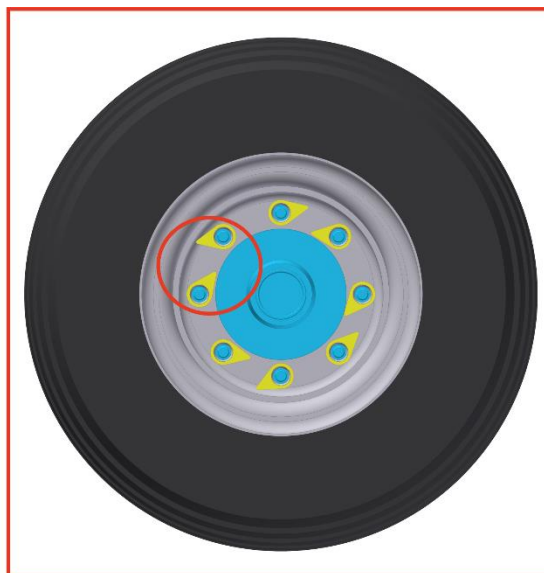

DANGER – WHEEL NUTS HAVE LOOSENED!

4.1 SHARP MACHINE PROJECTION



- The machine contains sharp structural projections.
- **It is prohibited to operate and transport the machine on roads when visibility is reduced!!** - Persons or objects, or other road traffic participants could get caught.
- **The machine operator must be extra cautious when driving on roads and consider the width of the machine and safe distance from persons, vehicles and objects, or other road traffic participants!!**

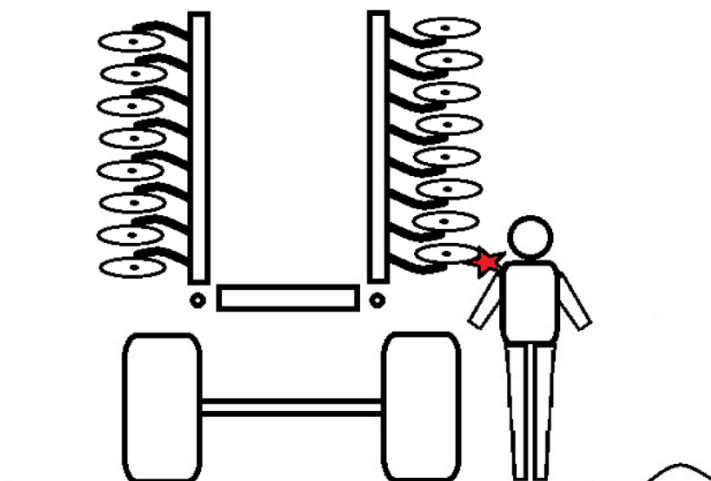

5 MACHINE ADJUSTMENT

5.1 MACHINE WORKING DEPTH ADJUSTMENT

Picture 13 – Machine adjustment

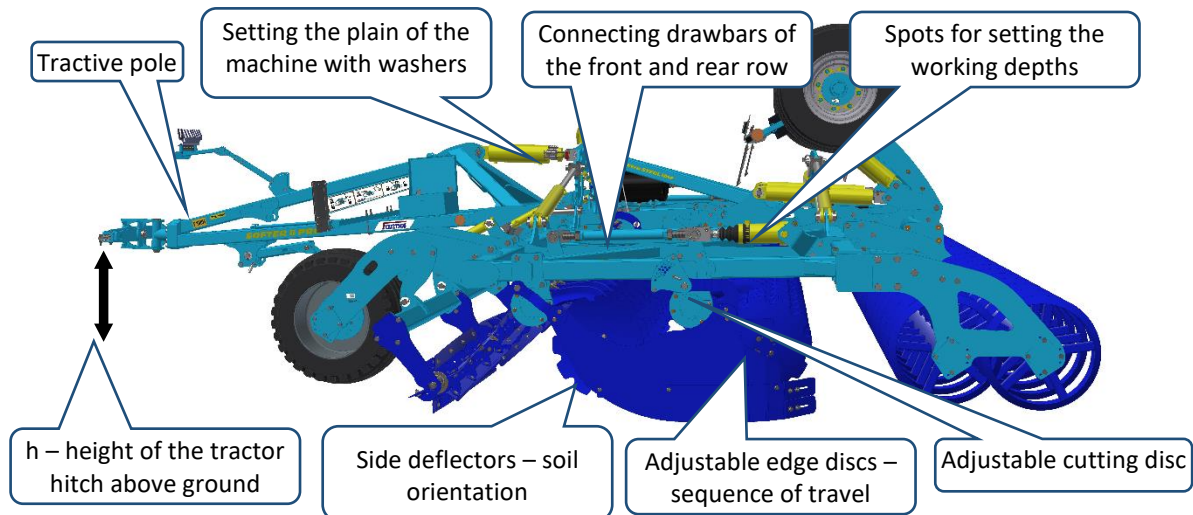

- The soil cultivation depth is set hydraulically (green dusters) from the tractor cabin.
- The current **working depth in centimetres** can be read on the indicator (Picture).
- When turning at headland, it is restored in order to achieve evenness along the entire width of the machine.
- To restore the depth when turning, it is required to keep maximum pressure in the yellow circuit for about 2 seconds after the machine is lifted.
- The arrow position may be adjusted by changing the length of the drawbar.

Picture 14 Working depth indicator

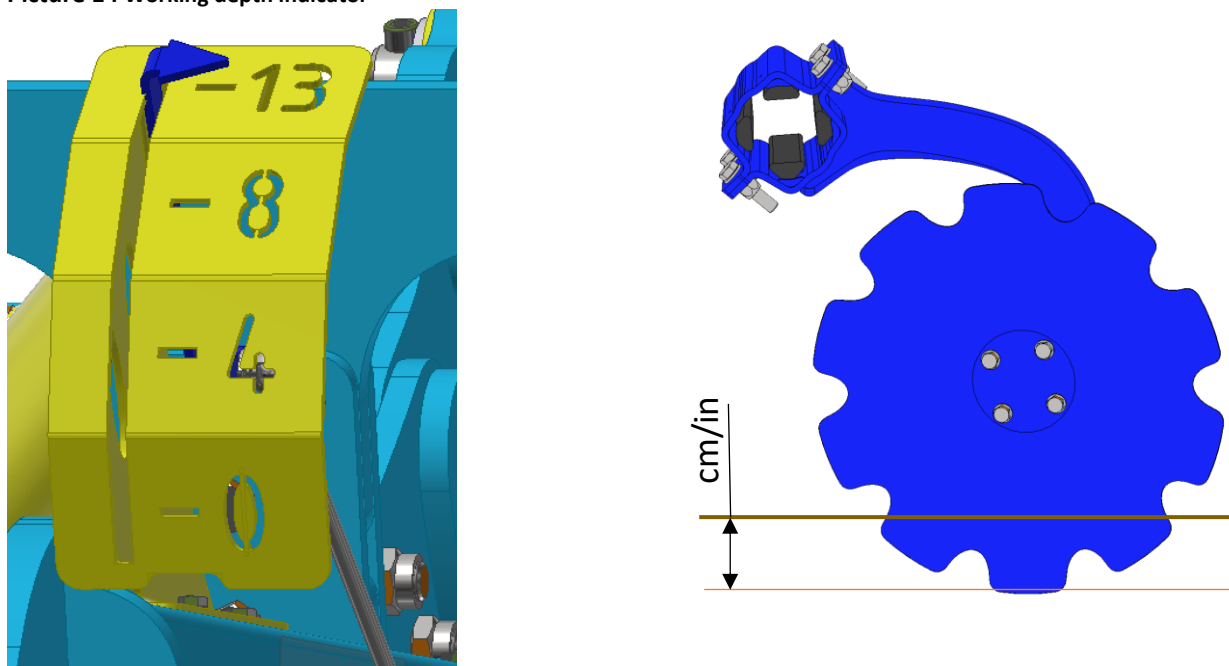

5.2 WASHERS ON THE DRAWBAR

- The number of washers is adjusted according to the height h of the tractor fixed hitch above ground (Picture 13)
- For the three-point hitch option, we recommend set the number of washers of the drawbar so that the tractor arms are in the horizontal position.
- The machine frame must be parallel with the ground when working
- The number of washers does not change when the working depth changes
- The colours of washers (Picture 15) are indicative
- All washers must be inserted for transport (mechanical end stop of the transport height)
- The number of washers is stated on the sticker (Picture 16)
- The number of washers is only indicative

Picture 15 Washers on the drawbar hydraulic

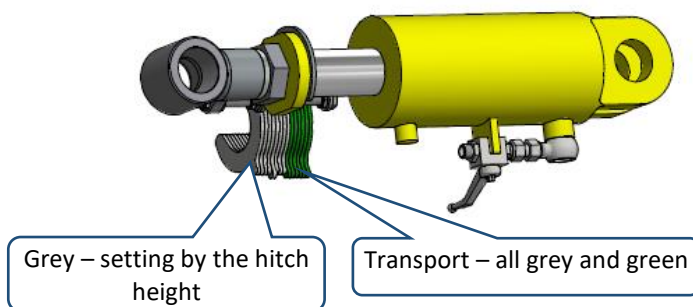

When transporting the machine on roads, all the washers must be used and the machine must be lowered onto the washers to achieve a height below 4 metres (13.1 ft).

Picture 16 Drawbar washer sticker

h [cm / in]		
0	70 / 28	
2	64 / 25	
4	59 / 23	
6	53 / 21	
8	47 / 19	
11	TRANSPORT	

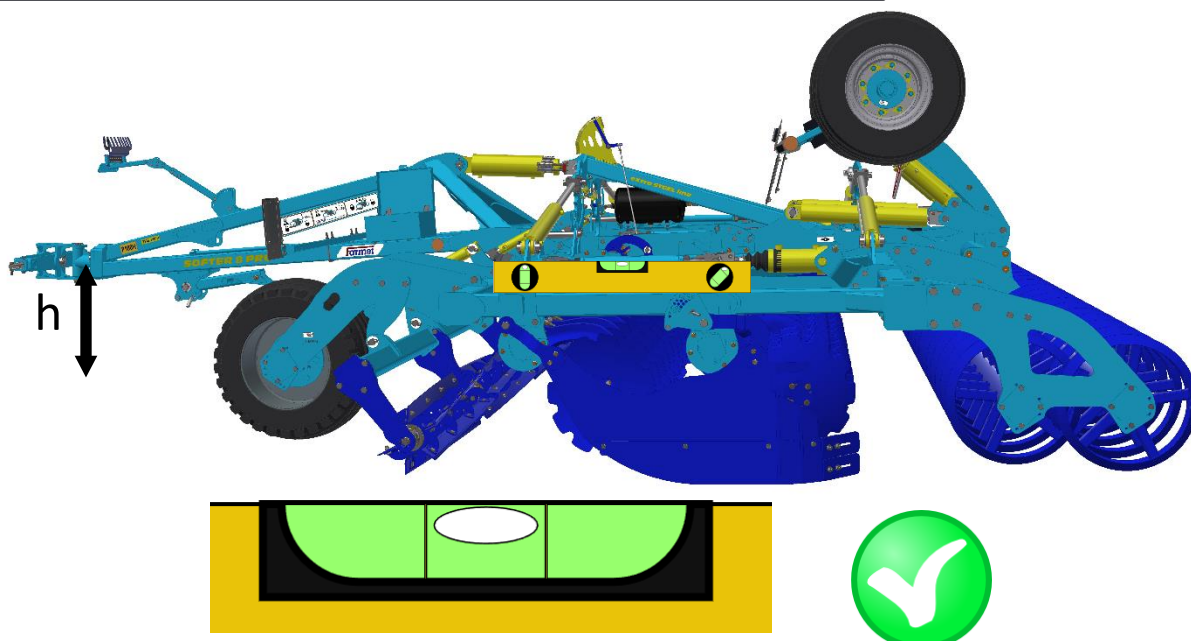

5.3 SETTING THE FRONT EQUIPMENT

- The front equipment is set from the cabin by the blue hydraulic circuit
- The position and pressure are set during work machine
- The machine may be equipped with a cutting roller or a flexible leveller
- The setting is independent of the disc working depth setting
- There are flow limiters in the circuit
- It may be deactivated when there is a large quantity of crop residue by completely lifting
- An excessive down pressure on the front cutting roller may worsen recessing of the discs

Picture 17 Front tool piston rod

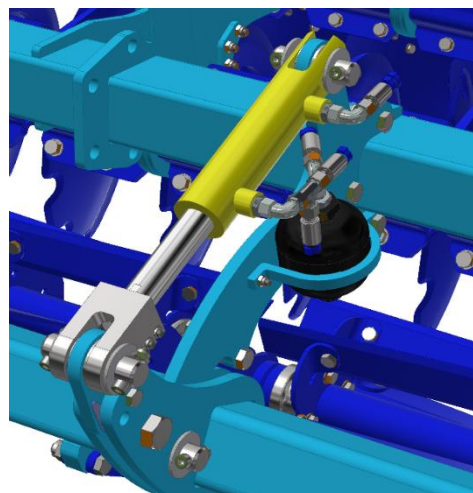

5.3.1 Setting the cutting cylinder lock Flexi-cut

- The cutting roller is protected against overload (example running onto a stone, etc.) with a nitrogen battery.
 - The release force is set by the pressure in the system when the machine is in the working position.
 - The set pressure can be monitored on the manometer on the drawbar (Picture 18)
 - The recommended pressure is 70 bar (1015 Psi), it is marked by an arrow on the manometer.
 - Never set the pressure higher than 70 bar (1015 Psi)
- It is prohibited to set pressure at the top when turning at headland. The pressure in the system can increase above the maximum permitted pressure when lowered to the ground.

Picture 18 Cutting cylinder safety pressure gauge

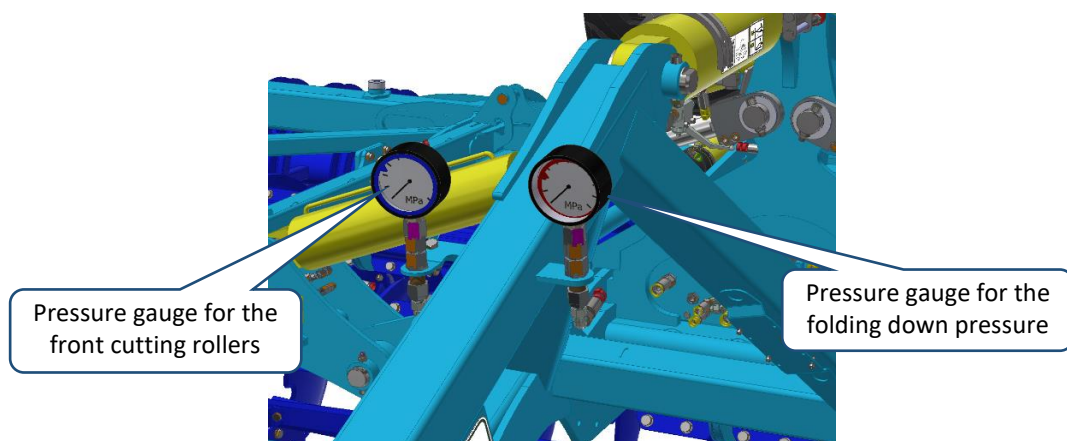

5.4 SETTING SIDE DEFLECTORS

- According to the type and quantity of plant residues, it is necessary to set the side deflectors.
- The height is set by changing the pin (lower stopper).
- Longitudinal adjustment of the extender is realized by repositioning it in the slotted hole.
- The longitudinal adjustment of the extender is performed by remounting in the longitudinal opening.
- When folding, always check that the correct turning has occurred when folding. There is a risk of collision with the central frame.
- When folding, the deflector must be manually moved from the working to the transport position to lower transport height.



Attention! Check for any collision when folding the machine in the case the deflector is set longitudinally.

Attention! The upper deflector limit must never be set. There is a risk of damage if the deflector is not sufficiently rotated when folding the frames.

Picture 19 – Options for side deflector settings

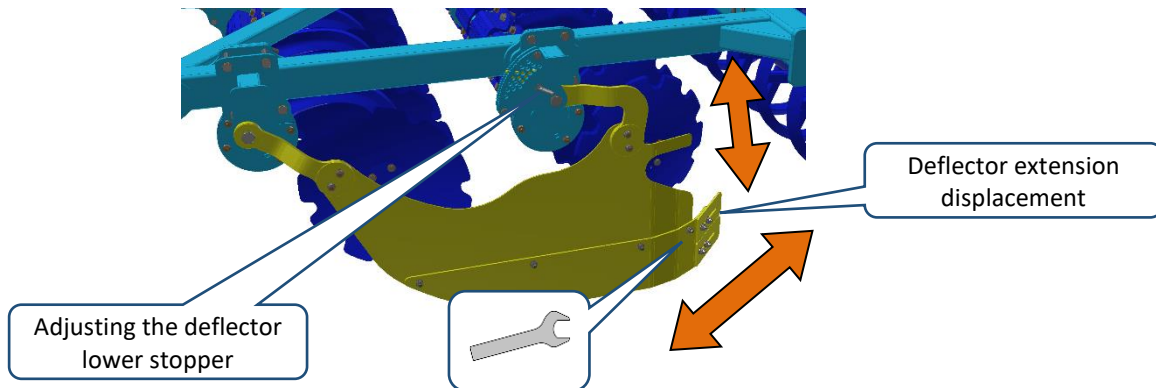

5.5 SETTING EDGE DISCS

- The edge discs on both sides of the machine have an adjustable position and they can be recessed differently to the other discs.
- The adjustment is executed so that the working depth of the edge discs is lower (approx. $\frac{1}{2}$ - $\frac{1}{4}$ of the depth of the other discs).
- Proper setting is important for the sequence of travel without any unevenness.
- The setting may be changed when the working depth, soil conditions and so on are changed.
- Position 1 is the highest depth of the edge disc, position 6 is the lowest depth.
- The initial setting for depth is 8 cm (3.15 in), position 3 (see the picture 20)

Picture 20 – Options for edge disc settings

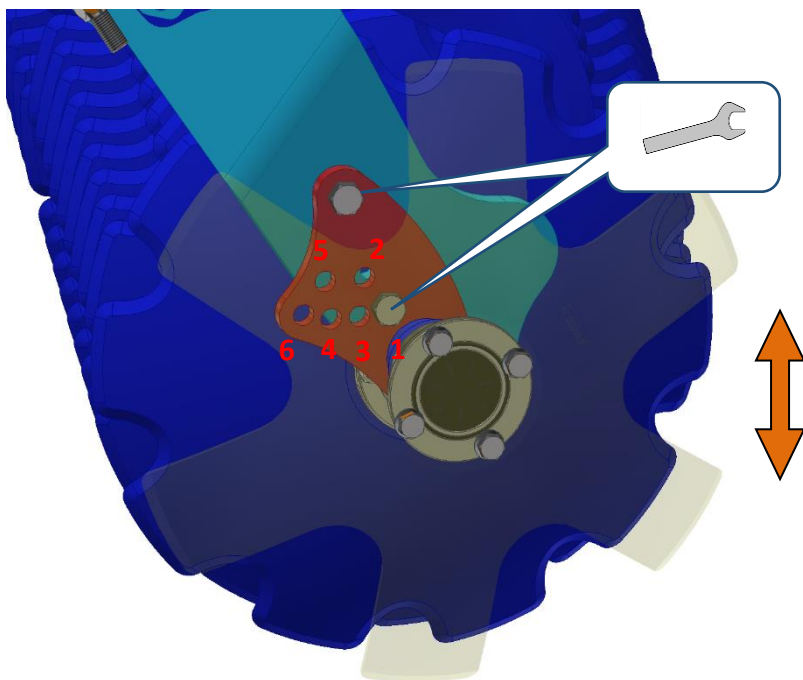

5.6 SETTING THE CUTTING DISC

- The disc is located in the middle of the rear row of symmetric discs.
- The disc may be changed to various positions according to the current soil conditions.
- The setting is used for cutting soil along the entire width of the machine and to create an even soil surface.
- The factory setting is shown in the picture (Picture 21)

Picture 21 Setting the cutting disc

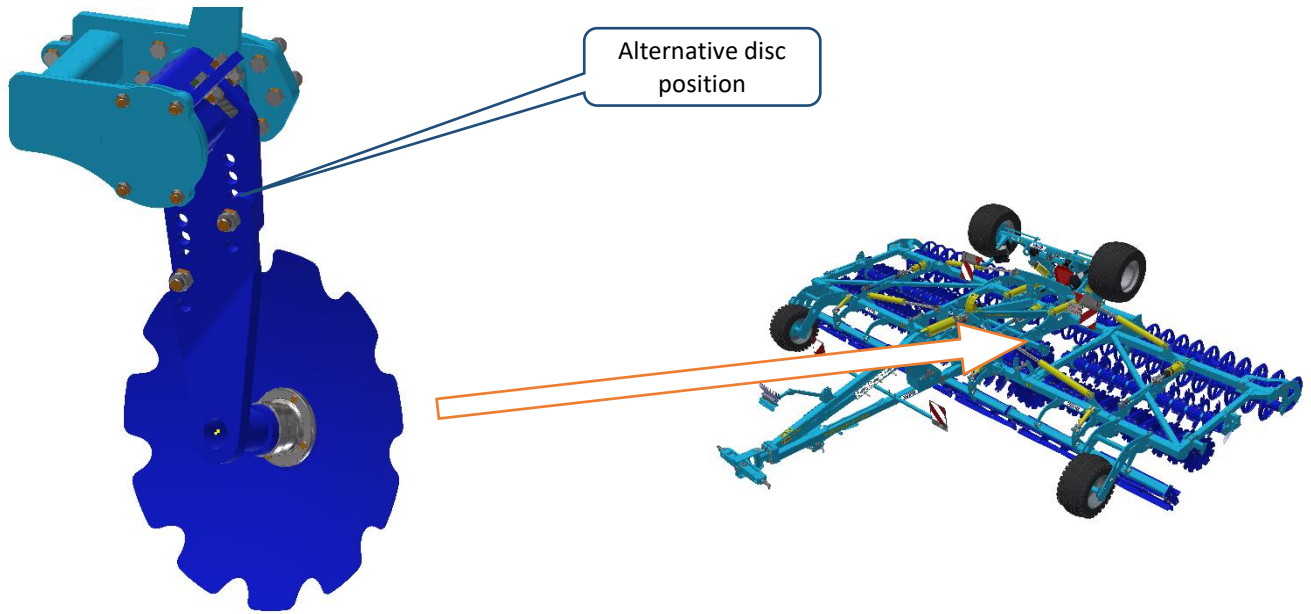

5.7 TURNING AT HEADLAND

- On the headland, turn only with the machine lifted on the rear roller (the working parts are not in the ground)
- **The primary method for turning at headland is on the rollers.**
- **It is possible to turn on the axle in specific cases.** (E.g., when rollers sink or there is not enough space to use them for turning.)
- Lift the machine using the yellow circuit.
- When lifted to the maximum height, keep the pressure in the yellow circuit at maximum for about 10 seconds (hydraulic cylinder restart)
- It consolidates the positions of the hydraulic cylinders of all frames at maximum depth.
- Use the yellow circuit to put machine back into the working position, draw the hydraulic cylinders of the drawbar into the limit position.
- The yellow circuit must be in the floating position during work to ensure downward tracing of the drawbar.

5.7.1 Turning on rollers

- The machine is only lifted by the drawbar piston rod, drawbar valve switched to the working position

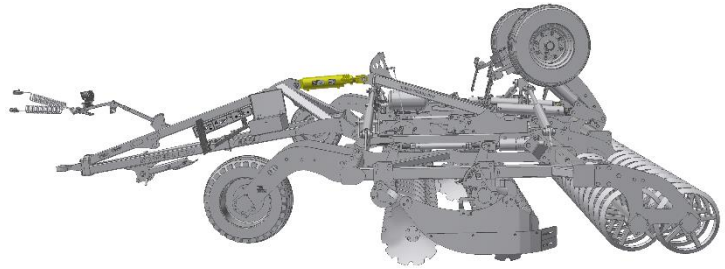
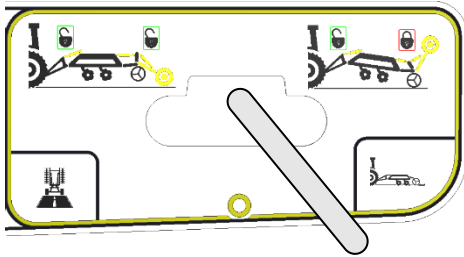

5.7.2 Turning on the axle

- The machine is lifted by the drawbar piston rod and the short axle piston rod

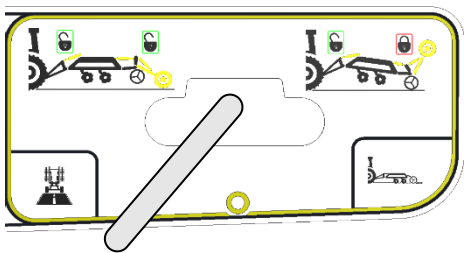

- The lever on the drawbar must be switched to the transport position
- The axle does not always have to be tilted all the way up to the end position

Picture 22 Axle position during work

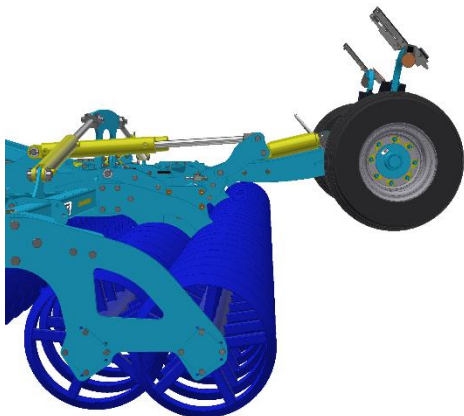

Picture 23 Axle position when turning

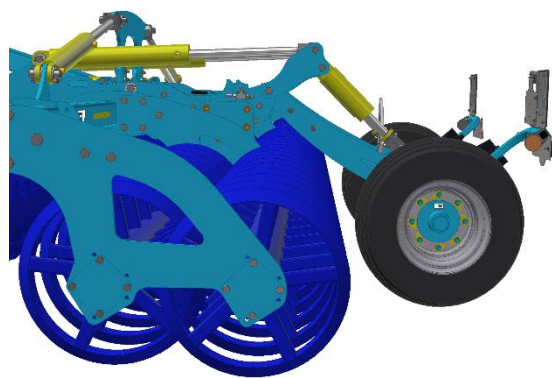

5.8 WORKING SPAN

- For theoretical working span of the machine see Tab. 2 – Technical Parameters of the Disc Cultivator (dimension Y)
- In practice or on a hillside, the working span may need to be reduced to ensure sufficient overlapping and undercutting of the stubble along the entire span
- Attention! The working span of the machine is not precisely symmetrical to the centre of the machine
- The working span on the right is about 0.1 m (0.3 ft) bigger than on the left side, see the picture (dimension X)

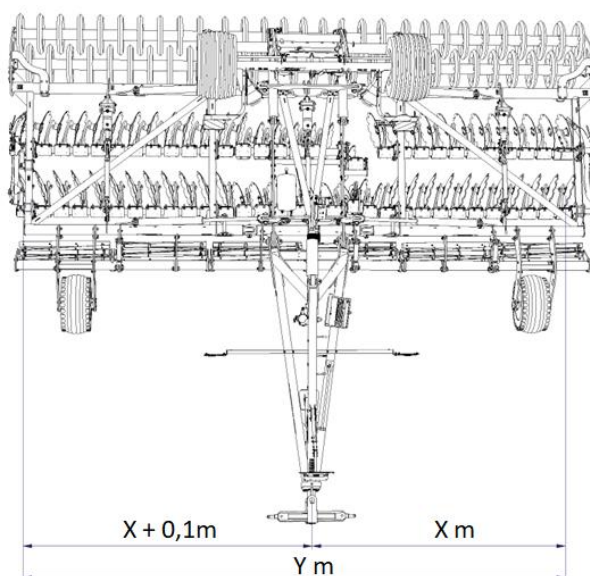

5.9 MACHINE TRAVELLING DIRECTION AT WORK

Change the direction of work with the machine by 15-30° to the previous seeding/harvest operation. That will help you achieve the best work results with the machine: a high crop residue throughput, mixing crop residue in and the levelling effect (levelling the tracks from previous operations)

Picture 24 Recommended direction of driving at work

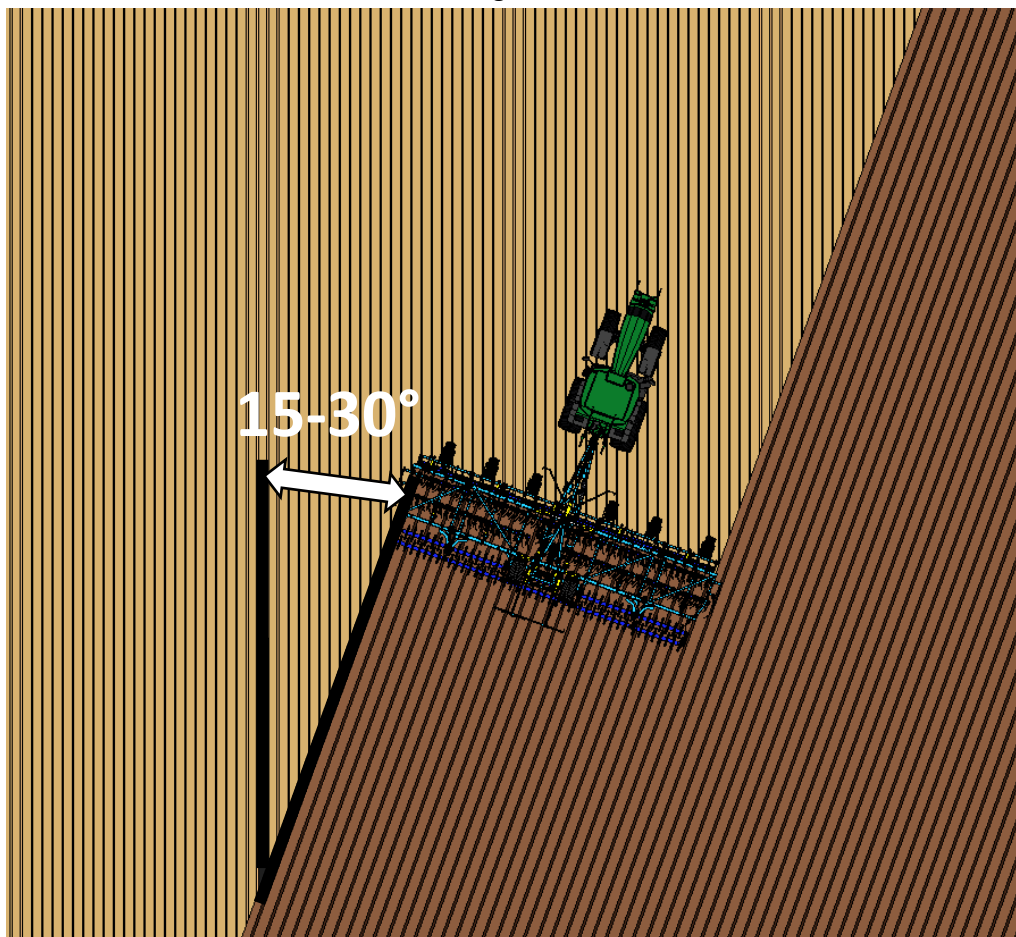

When the machine works in the same direction as in the previous operations (seeding/harvest), it can get clogged, which reduces the quality of work and the levelling effect of the machine.

6 ELECTRONIC HYDRAULIC CIRCUIT SWITCH

6.1 DESCRIPTION OF THE EQUIPMENT

The product is designed for electronic division and control of the hydraulic circuits. Primarily, the system has one input circuit and three output circuits, while the selection of the individual circuits is done via an electronic controller from the tractor cabin.

Thus, we are reducing the final number of connected hydraulic circuits between the tractor and the machine.

6.2 SYSTEM WIRING DIAGRAM

6.2.1 Designation of system components

1	Output 1 – CIRCUIT 1 CONTROL
2	Output 2 – CIRCUIT 2 CONTROL
3	Output 3 – CIRCUIT 3 CONTROL
4	Electrohydraulic valve of CIRCUIT 1
5	Electrohydraulic valve of CIRCUIT 2
6	Electrohydraulic valve of CIRCUIT 3
7	Ball valve
8	Tractor quick-couplers
9	Controller
10	Electric line between the hydraulic block and controller, with a disconnecting connector
11	Supply cable of the system, equipped with a fuse
12	Tractor power socket

6.2.2 Wiring diagram

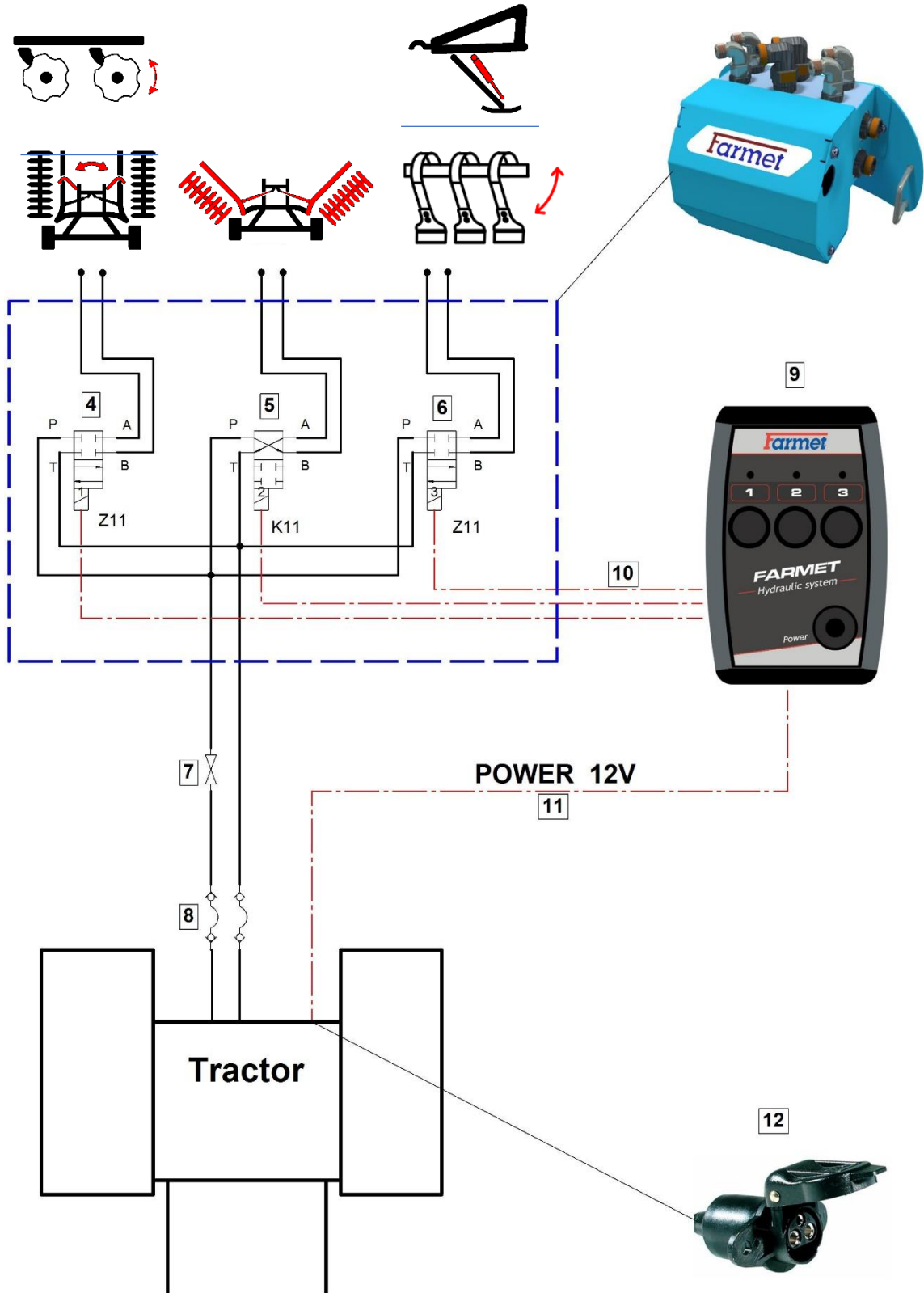

6.3 MAIN COMPONENTS

6.3.1 Controller

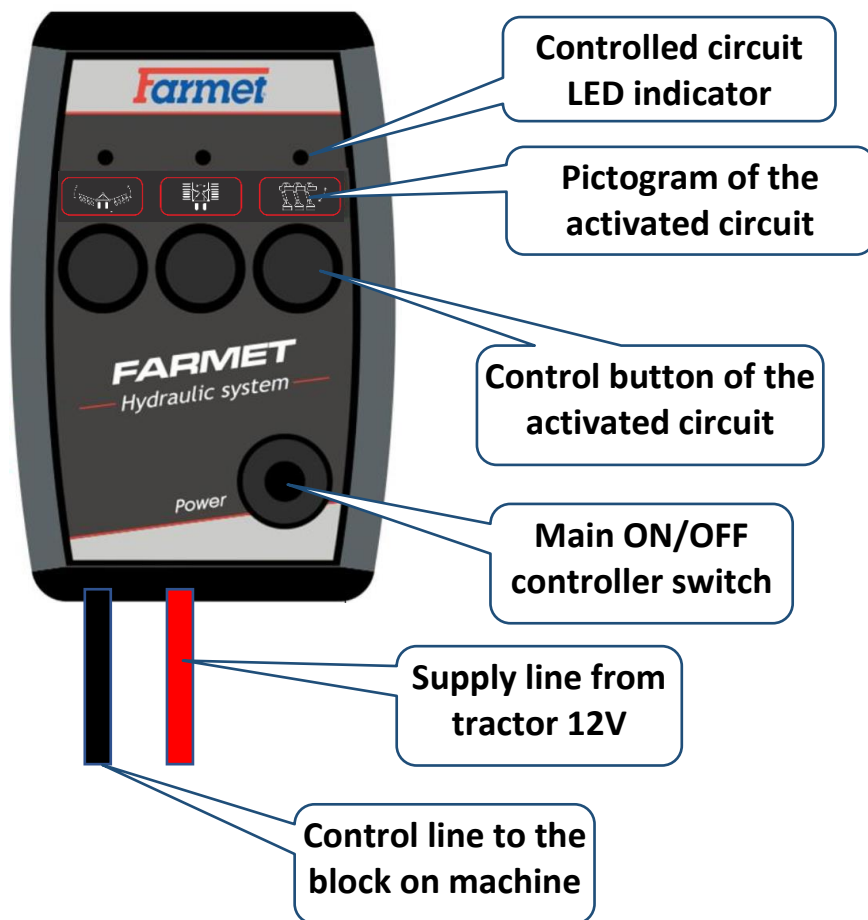

6.3.2 Hydraulic block

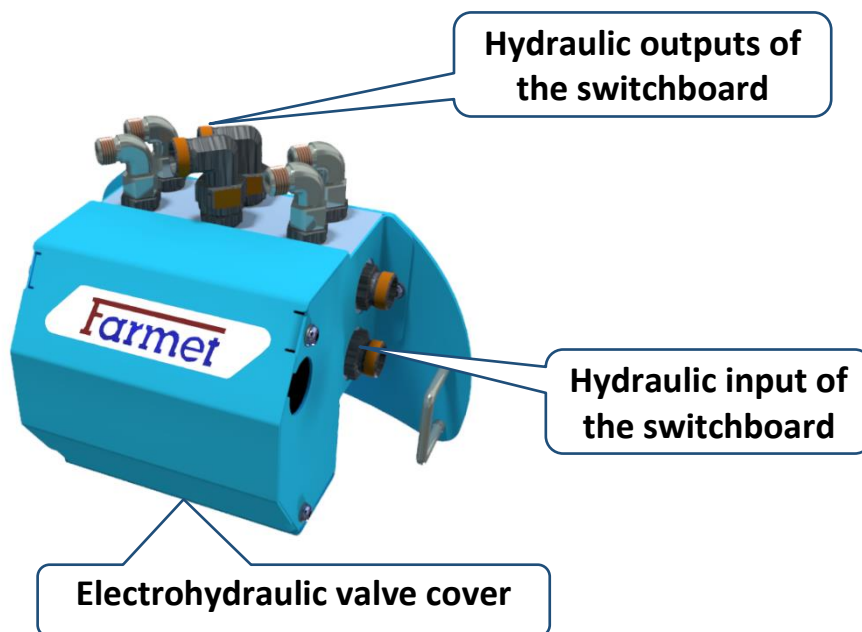

6.3.3 Power supply

- The system is powered from the tractor network.
- To ensure proper function of the system, the voltage in the accumulator must be within the range of 12 V – 14.4 V /10A.
- Power supply is provided via a three-pole tractor socket or ignitor socket.
- The supply line is equipped with a small knife-blade-contact fuse at 5A.
- Never replace the fuse with a different value.



6.4 FUNCTIONS + PICTOGRAMS

POWER button – Activates the power supply of the control device and launches the system. It is indicated by the red diode when activated.

Circuit selection buttons – The individual circuits are selected using the control buttons of the individual circuits. Each button has a pictogram assigned to identify the controlled circuit. Only one selected circuit is active and it is signalled by the green diode above the pictogram.

List of used pictograms:

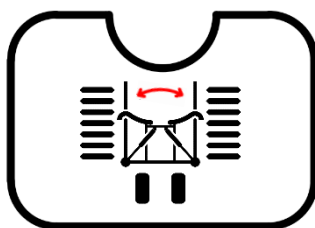

Frame locking

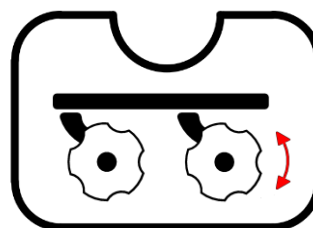

Depth of discs

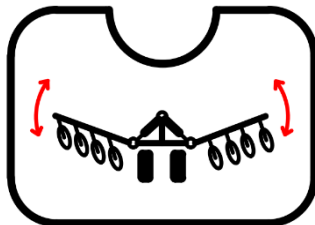

Machine folding

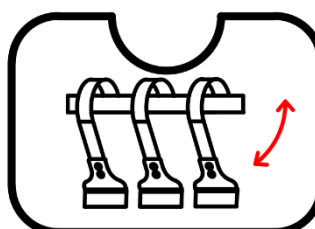

Front equipment

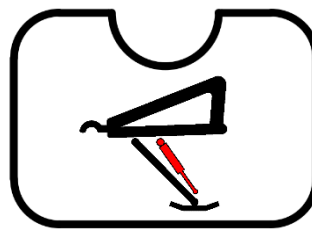

Support leg

6.5 CONNECTING PROCEDURE

1. Installation of the controller in the tractor cabin
2. Connection with the machine
3. Connection with the electric source
4. System activation using the Power button
5. Circuit selection

6.6 EMERGENCY STATE

A defect in the electric installation or the tractor power supply is considered to be an emergency state. When completely disconnected, turned off or in the case of a failure, it is always possible to control the **Frame Folding** circuit (as an initial one, with a reversed switching function)

Manual emergency control

- The switchboard may be controlled mechanically in emergency
- The control is performed by manually pressing the gate valve of the switchboard via the spring (e.g., using a suitable bar with a diameter of about 3 mm / 0.12 in)
- The switchboard cover has holes on the bottom side for this case
- Example: "Frame Folding" circuit control
 - Close this circuit by pressing the gate valve of the "Frame Protection" (the gate valve has a reversed function, the circuit is open without voltage)
 - Open this circuit by pressing the "Frame Folding" gate valve
 - Control the selected circuit by the oil pressure from the tractor

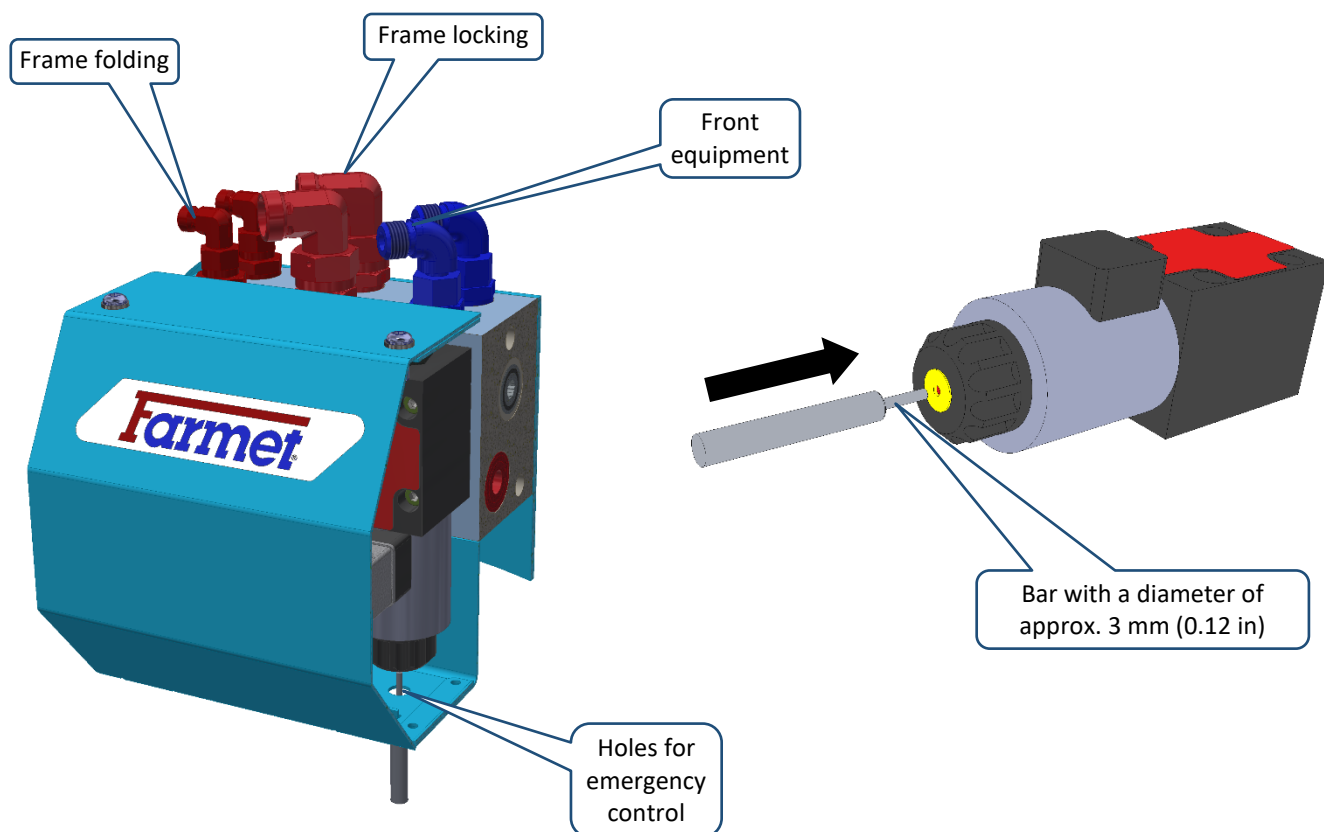

7 ADJUSTMENT AND MAINTENANCE PROCEDURES

7.1 SETTING THE HOSE MOUNT

- The hose mount and their length must be set so that they are not damaged when working in the field or being transported, as well as when taking turns.
- It is possible to set the angle of the mount and its extension.
- The hoses may be moved in the mount after loosening the wing nuts.
- Check in all positions that the hoses are not excessively stretched and that they cannot be caught by the tractor shoulders.

Picture 25 Hose mount

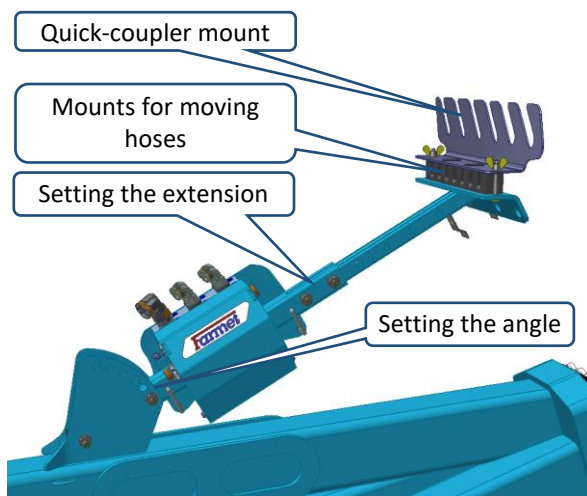

7.2 DEPTH CONNECTING RODS FOR THE FRONT ROW

- The working depth is set at the rear row of discs
- The front row is connected to its using an adjustable connecting rod
- The setting does not have to be adjusted in regular conditions
- With correct factory settings, the distance between the lug and the lock nut is 30 mm (1.2 in) (Picture 26), and it is the same on both sides
- With correct setting, the front and the rear row of discs works in the same working depth

Picture 26 Setting the connecting rod

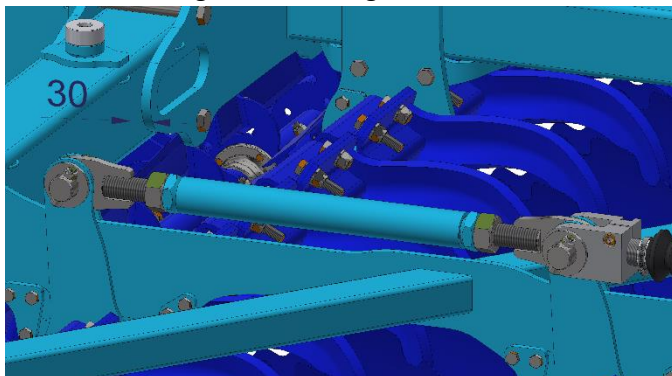

7.3 TRACING WHEEL POSITION

- The bearings of the tracing wheels may be mounted to different positions on the frame.
- The factory setting is used according to the selected roller.
- SDR, DVR, DRR roller – position 3.
- The setting does not need to be changed in regular conditions.
- The setting must correspond to the number of washers on the drawbar and the tractor hitch height.

Picture 27 Setting the tracing wheels

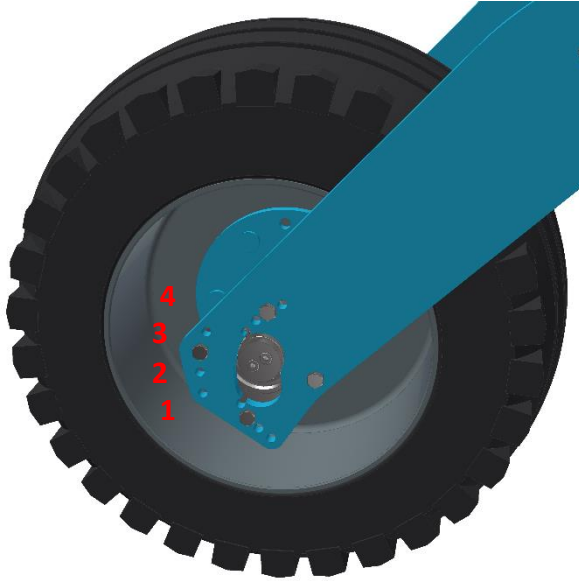

7.4 ROLLER POSITIONS

- The roller bearings may be mounted in different positions on the side plates
- The factory setting is set at the lower position (position 1)
- The setting does not usually need to be changed
- Settings may differ according to the roller type.

Picture 28 Setting the roller positions

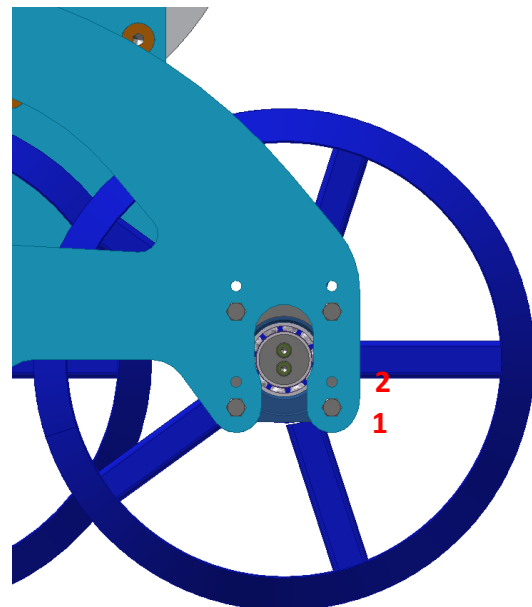

7.5 END STROKE VALVE

- Used on the central roller and side frames
- Axle switch: The central roller should start moving down after the valve in the top position of the axle is switched on
- The valve is factory-adjusted and does not need any readjustment
- S Adjustment is made with a stop bolt on the frame

Attention! When the valve is switched on, the central roller may start to move unexpectedly.

Adjustment

- 1) Hydraulically adjust the axle to the desired top end position for valve actuation
- 2) Slightly push the pin of the switching valve upwards by adjusting the stop bolt
- 3) Loosen the adjusting screw by approx. 2 mm (0.03 in) so that the stop pin slides out a little

Picture 29 Setting the switch valve

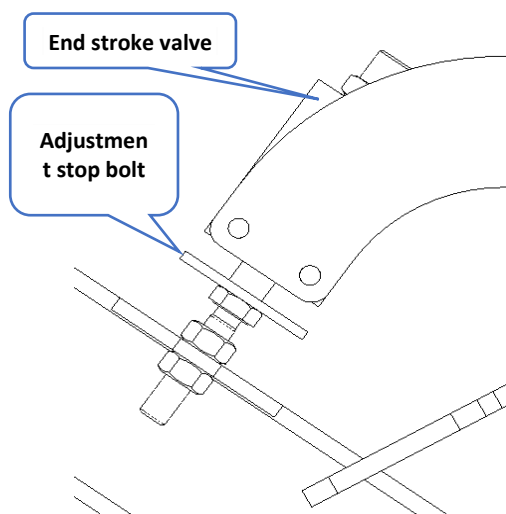

7.6 SIDE FRAME STOPPERS

- The central frame has stoppers for the side frames for folding
- The stops serve to define the end position and the correct function of the locking hooks
- When properly adjusted, the folded side frames are exactly vertical

Picture 30 Side frame stoppers

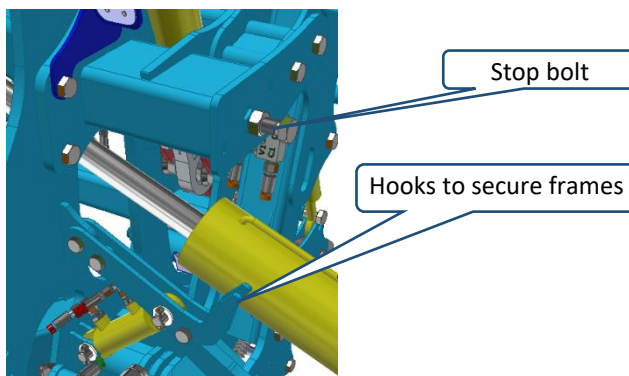

7.7 TOWING LUG WEAR CHECK

- Always check the wear of the towing lug before the season
- If the wear is close to the limit, shorten the inspection interval, and if the limit is exceeded, immediately replace the worn parts
- The wear can be reduced by applying plastic grease according to Chapter 11 regularly

Lug C50

Description	Rated dimension (mm/in)	Wear dimension (mm/in)
Lug diameter A	51/2	53/2
Lug height H	54/2.1	51,5/2
Lug thickness T	25,5/1	23/0.9

Lug C70

Description	Rated dimension (mm/in)	Wear dimension (mm/in)
Lug diameter A	71/2.8	73/2.9
Lug height H	54/2.1	51,5/2
Lug thickness T	25,5/1	23/0.9

Picture 31 Checked towing lug dimensions

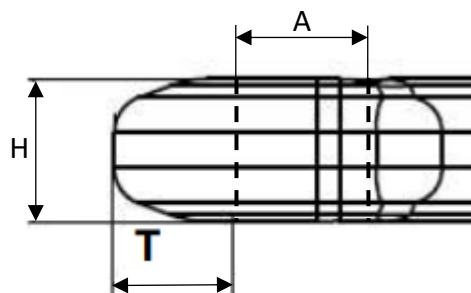

Ball K80

- To assess the wear of the K80 hitch, a special gauge must be used (Picture 32)
- If the gauge falls all the way to the bottom of the hitch head, the head is worn out too much and must be replaced

Picture 32 Gauge for assessing the wear of K80

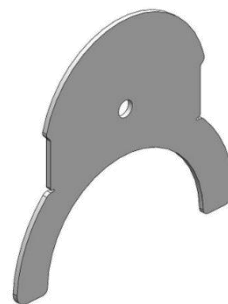

Retainer clearance adjustment

- Regularly check the retainer clearance according to the tractor manufacturer's instructions
- The clearance between the retainer and the hitch head shall not exceed 0.5 mm (0,02 in)
- If the clearance cannot be adjusted, replace the worn part with a new one

7.8 AIR JET DRAINAGE

- Drain the air jet regularly once a week, according to the maintenance plan.
- Drain water without any air pressure in the air jet.
- Excessive water amount may corrode the brake system



Drain valve

8 TROUBLESHOOTING

8.1 UNFOLDING AND FOLDING

Problem	Possible cause	Remedy
The machine cannot be unfolded	Closed valve for axle locking and folding on the drawbar panel	Open the valve on the drawbar panel, see Chapter 1.2
	Secured frame hooks	Release the frame hooks with hydraulics, Chapter 1.6
	Hydraulic circuit switch set to a different circuit	Use the controller to switch to the right circuit – i.e., folding
	Hydraulics not connected correctly	Connect both red quick couplings into one tractor circuit
The machine cannot be folded	Hydraulic circuit switch set to a different circuit	Use the controller to switch to the right circuit – i.e., folding
	Closed valve on the panel	Open the valve for transport on the drawbar panel, see Chapter 1.2
	Frame securing hooks in the top position	Release the frame hooks in the bottom position using hydraulics, Chapter 1.6
	Frame weight too high – stuck soil	Clean the frames and rollers from stuck soil
	Stuck soil blocks the folding joints	Clean stuck soil from the joints
The axle do not move	Closed valve on the drawbar	Adjust the valve for turning at headland into the transport position, Chapter 1.2
	Axle brake is engaged	Release the axle brake before moving
	Closed valve for axle locking and folding on the drawbar panel	Open the valve on the drawbar panel, see Chapter 1.2
	Axle is resting on transport lining	Set the transport lining to the unlocked position for work, see Chapter 1.7
	Hydraulics not connected properly	Connect both yellow quick couplings into one tractor circuit
The hydraulic circuit switch does not work – not lit	Not connected to the power supply	Connect the switch to the tractor power supply, Chapter 6.3.3
	Burnt fuse	Check the thermal fuse on the cable, or replace it, Chapter 6.3.3
The hydraulic circuit switch does not work – not lit	Cable between tractor and machine not connected	Check the proper connection of cable, Chapter 6.2

8.2 FIELD WORK

Problem	Possible cause	Remedy
Uneven cultivation depth	Insufficient reset of the depth piston rods	Extend the time of yellow circuit activation when turning at headland, reset the piston rods in the limit position, Chapter 5.1
	Soil stuck on the disc movement mechanism	Check that discs move freely in full extent
	Insufficiently unfolded frames	One frame may be delayed when unfolding, unfold the frames for a sufficient period of time
	Improper down pressure in the folding circuit	Check the down pressure of the folding circuit on the pressure gauge, or set to 80 bar, Chapter 3.3
A groove is created during the next pass	Adjustable edge disc is too low	Set the disc a bit higher, Chapter 5.5
	Edge deflector is too low	Set the deflector end stop at a higher position, Chapter 5.4
	Adjust the machine working width	Try to lower or increase the working width
A ridge is created during the next pass	Adjustable edge disc is too high	Set the disc a bit lower, Chapter 5.5
	Edge deflector is too high	Set the deflector end stop at a lower position, Chapter 5.4
	Adjust the machine working width	Try to lower or increase the working width
Soil is not undercut evenly in the centre of the machine	Adjust the setting of the cutting disc	Set the cutting disc at a higher or lower position according to the conditions, Chapter 5.5
Machine is clogged between discs	Too much material in the machine	Reduce the working depth
	Working speed too high	Try to reduce working speed so that material has enough time to fall through
	Soil moisture too high	Stop work and wait for more suitable soil conditions
	Driving in the row direction	Work with the machine diagonally to the direction of rows, choose more diagonal passes
Cutting rollers get clogged	Insufficient roller turning speed	Increase working speed
	Soil moisture too high	Deactivate the rollers
	Driving in the row direction	Work with the machine diagonally to the direction of rows, choose more diagonal passes
Cutting rollers do not move	Circuit switch is not switched to the front tool	Change the circuit switch to front tool, check power supply and function
	Hydraulics not connected properly	Connect both red quick couplings into one tractor circuit
The required disc working depth cannot be set	The machine is lifted using the yellow circuit	Working depth cannot be set in the lifted position, depth reset at headland function
	Closed disc valve on the drawbar	Open the disc valve on the drawbar, Chapter 1.2
	Hydraulics not connected properly	Connect both green quick couplings into one tractor circuit
	Soil stuck on the disc movement mechanism	Check that discs move freely in full extent
Uneven cultivation depth	Working speed too high	Reduce working speed
	Inappropriate depth of the cutting disc	Try to adjust the depth of the cutting roller

9 MACHINE MAINTENANCE AND REPAIRS



Observe the safety instructions for treatment and maintenance.

- If it is necessary to weld during the repair and have the machine connected to the tractor, it must have disconnected supply cables from the alternator and the accumulator.
- Check the tightening of all screw and other assembly connections at the machine before every use of the machine, furthermore continuously as needed.
- Continuously check the wear of the working bodies of the machine, possibly replace these worn working bodies with new ones.
- Adjustment, cleaning, and lubrication of the machine may only be performed with the machine at rest (i.e. the machine is standing and not working).
- When working on a lifted machine, use suitable support equipment supported at marked points or at points suitable for that.
- During adjustment, cleaning, maintenance, and repair of the machine, you must secure those parts of the machine that could endanger the operator by falling or another movement.
- For catching the machine during handling using lifting equipment, use only the places marked with self-adhesive labels with the chain sign "—○—○—".
- Upon a failure or damage of the machine, immediately turn off the tractor's engine and secure against restarting, secure the machine against movement ⇒ only then you can remove the failure.
- During repairs of the machine, use exclusively the genuine spare parts, suitable tools and protective equipment.
- Regularly check the prescribed pressure in the machine tyres and the condition of the tyres. Perform possible repairs of the tyres in an expert workshop.
- **Regularly check the "check points" for nut loosening according to the manual.**
- Keep the machine clean.



Do not clean hydraulic cylinders and bearings with a high-pressure cleaner or direct water stream. The seals and bearings are not watertight at high pressure.

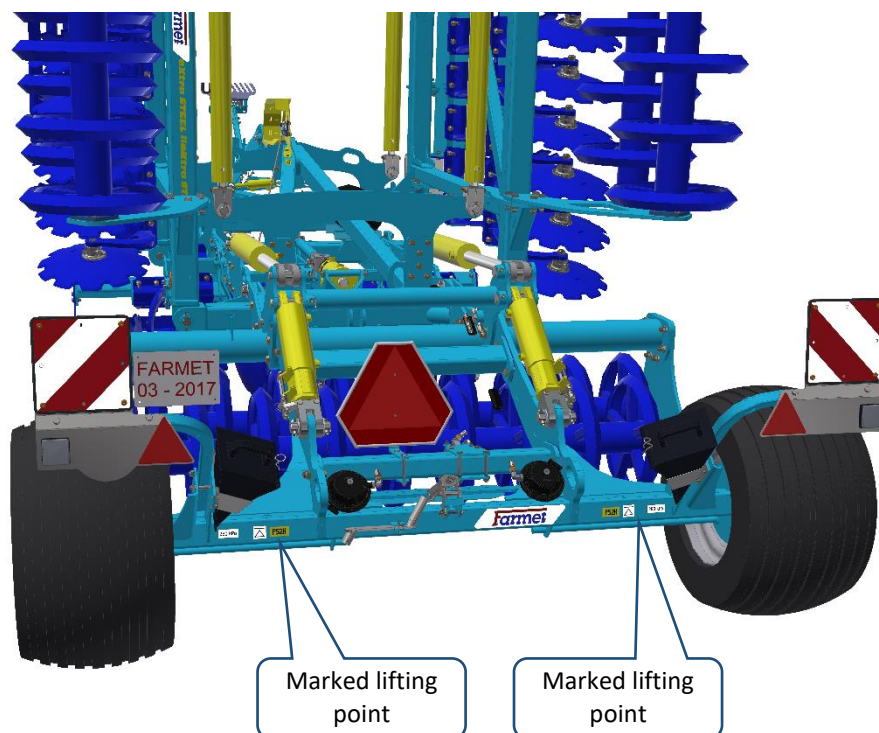

9.1 REPLACEMENT OF THE WORKING ROLLER BEARINGS

- Always follow the safety regulations and directives when replacing the bearings of rollers.
- The machine must be aggregated with the tractor according to Chapter “3.1/p.24” when replacing the bearings. The tractor engine must be switched off for the replacement of bearings and the operator, or repairman, must prevent any access to unauthorised persons to the tractor.
- Only replace the roller bearings on a solid and flat ground and when the machine is in standstill.
- In the case of leaks in the tractor hydraulic system, you are required to provide mechanical supports under the machine drawbar.

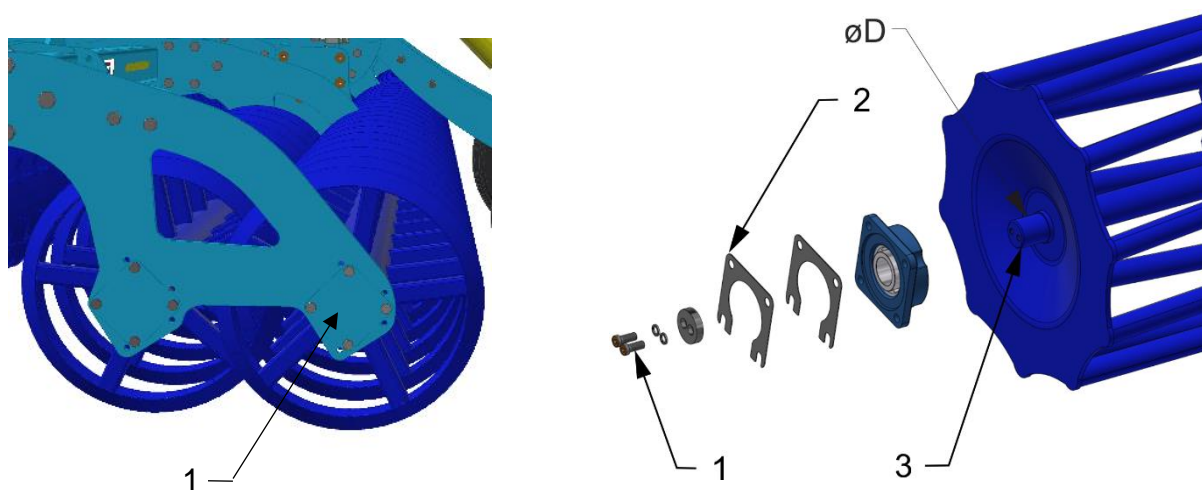

<p>1 – Roller bearing</p>	<p>1 – Bolt 2 – Spacers 3 – Pin cylinder øD – 40 mm (1.6 in) – Bolt M10 (50 Nm) / M8 (20 Nm) øD – 45 mm (1,8 in) – Bolt M12 (86 Nm) / M10 (20 Nm) øD – 50 mm (2 in) – Bolt M12 (86 Nm) / M10 (20 Nm) øD – 60 mm (3.4 in) – Bolt M12 (86 Nm) / M10 (20 Nm)</p>
---------------------------	---

9.1.1 Using the tool for bearing disassembly and assembly

- The tool placed in the box on the machine

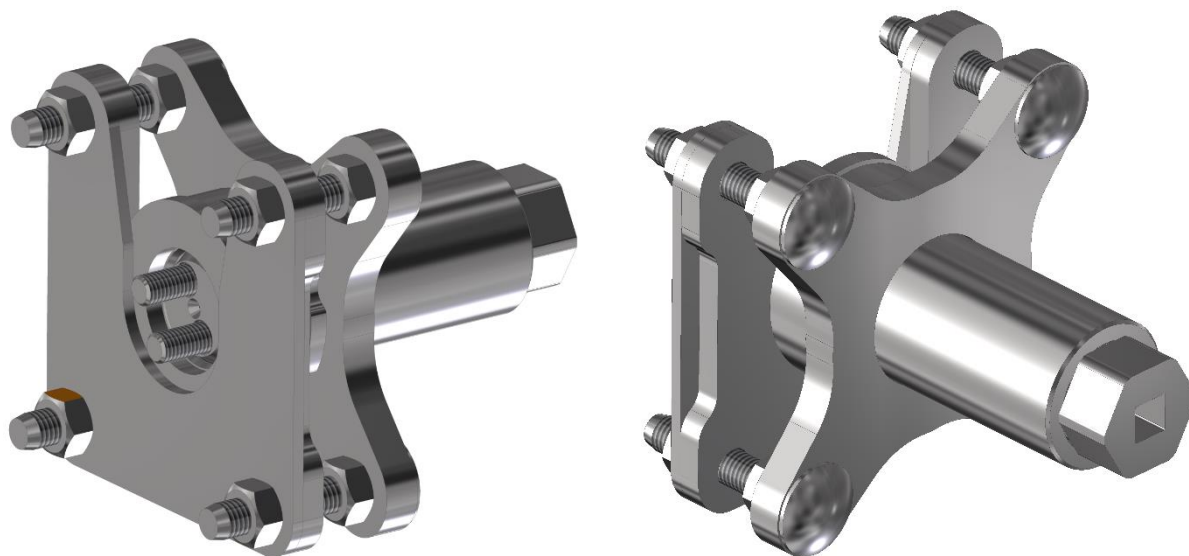

Tool parts:

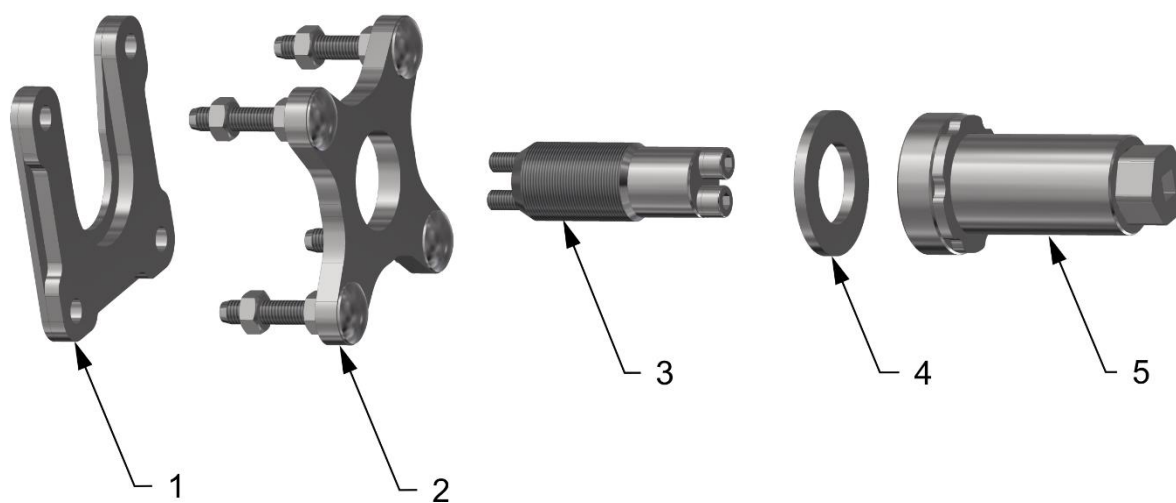

- 1 – Part for disassembling the bearing ring
- 2 – Part for disassembling the bearing or bearing ring
- 3 – Tool pin + bolts
- 4 – Liner
- 5 – Tool body

9.1.1.1 Complete bearing disassembly

- Procedure:
- 1 Mount and screw the tool pin onto the cylinder pin

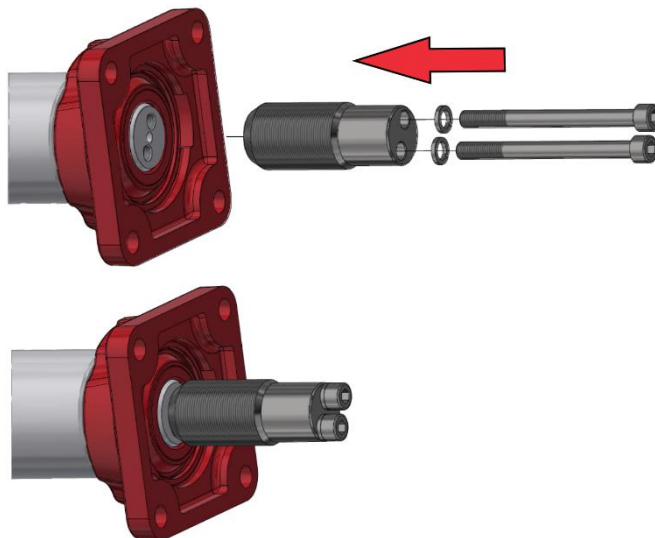

- 2 Screw the tool body in, insert the part for bearing disassembly and mount onto the bearing using the nuts

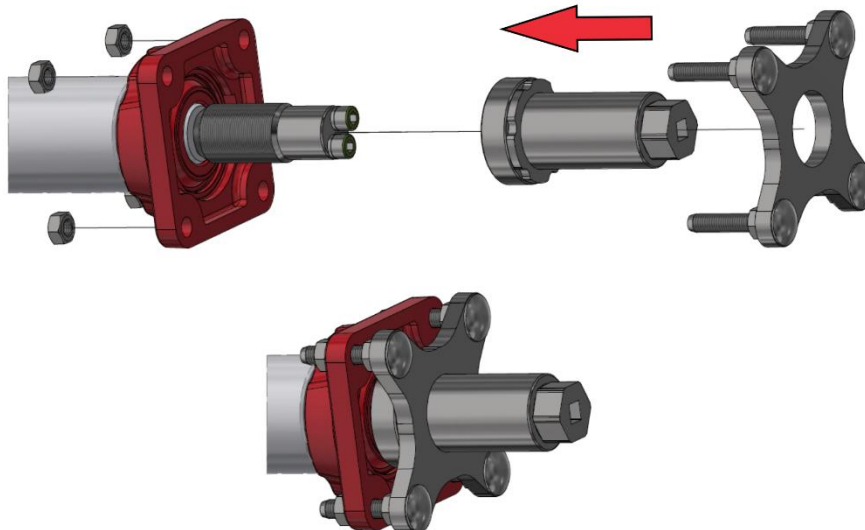

- 3 Disassemble the bearing by screwing the tool body using spanner size 36

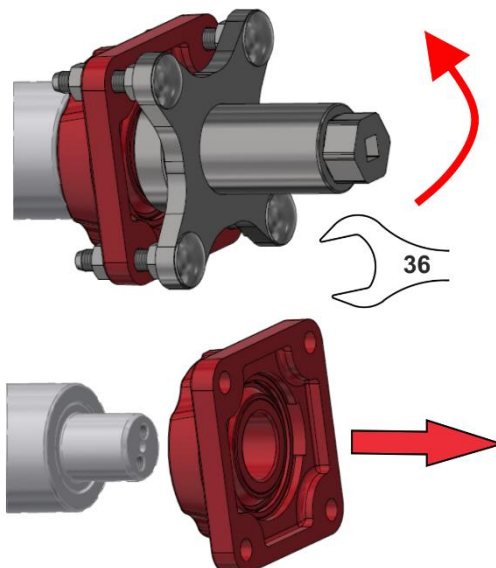

9.1.1.2 Disassembly of the ring

• Procedure:

- 1 Mount and screw the tool pin onto the cylinder pin

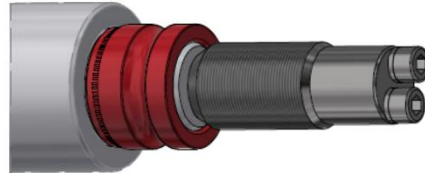
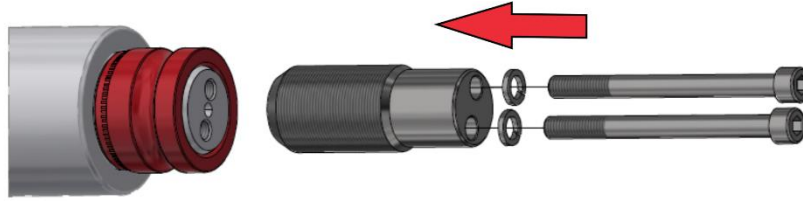

- 2 Screw the tool body, mount the part for disassembling the bearing, mount the part for disassembling the ring and attach it using the nuts

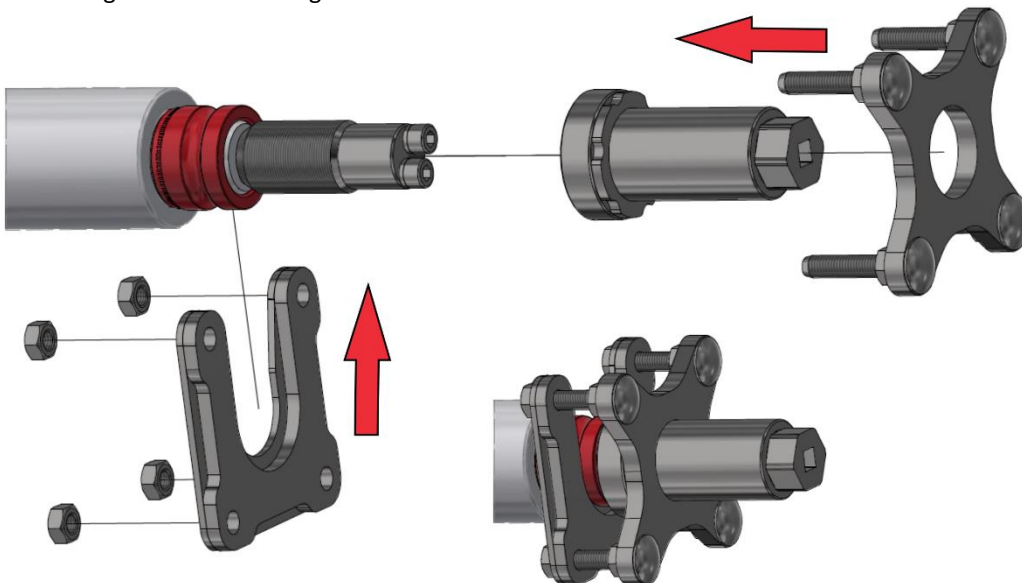

- 3 Disassemble the ring by screwing the tool body using spanner size 36

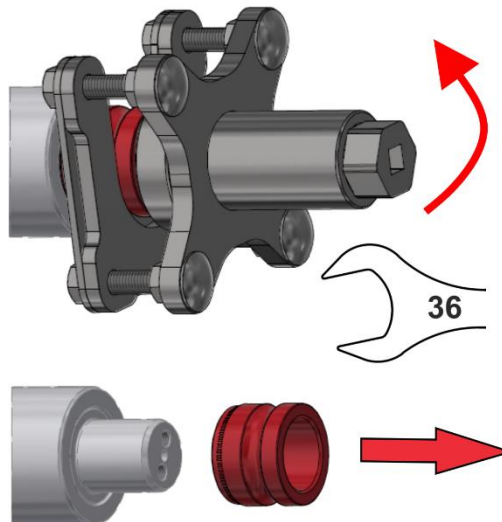

9.1.1.3 Assembling bearings onto pins

- Procedure:

1 Mount and screw the tool pin onto the cylinder pin



2 Mount the bearing + liner and screw the tool body in.

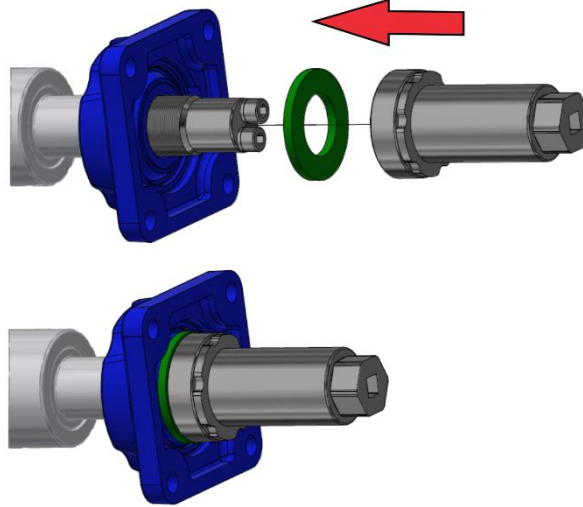

3 Assemble the bearing by screwing the tool body using spanner size 36

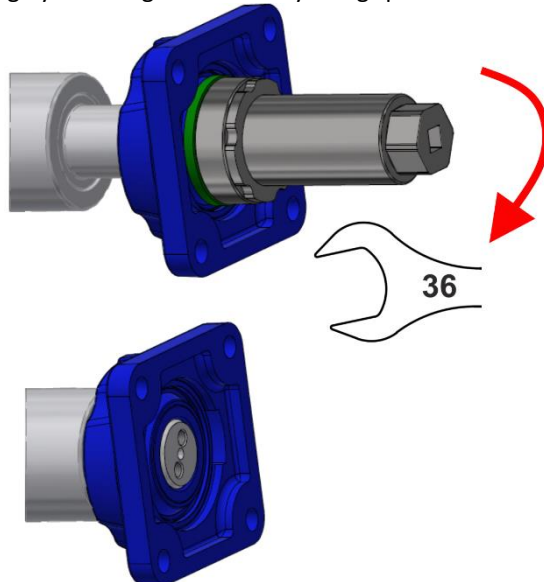

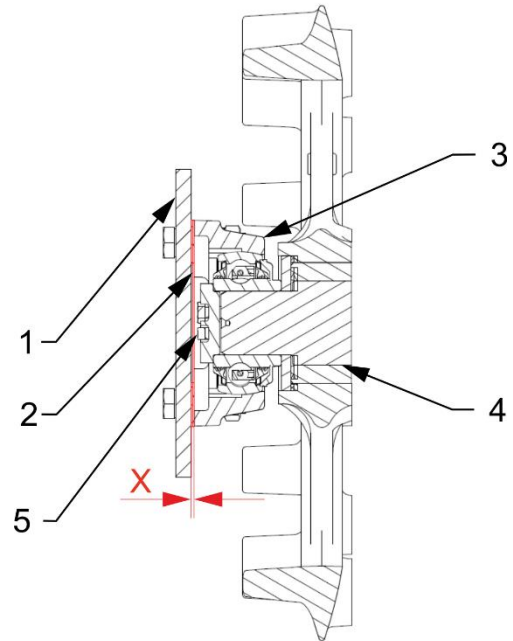
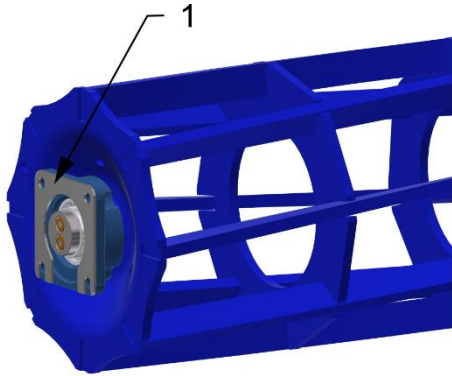

9.1.2 Using spacer

- The spacers are used for defining production tolerances. Therefore, they do not have to be always used.
 - Mount the house bearings to the rollers
 - Insert the roller with the bearings between the frame side plates and assess whether you need to use the SPACERS



<p>1 – Spacers</p>	<p>1 – Side plates 2 – Spacers 3 – House bearing 4 – Pin cylinder 5 – Bolt</p> <p>Parameter "X" = is there a gap? YES = Use spacers NO = Do not use spacers</p>
--------------------	--

9.2 MAINTENANCE PLAN

<h1 style="margin: 0;">MAINTENANCE PLAN</h1> <p style="margin: 0; font-weight: bold;">Perform the planned maintenance according to the instructions:</p>					
Maintenance Task	Daily (season) (10 hours)	Once a week (50 hours)	Before season	After season	Time interval
Machine in general					
<ul style="list-style-type: none"> • Visual inspection of the machine • Checking for any undesirable sounds, vibrations and excessive wear 	X				
<ul style="list-style-type: none"> • Checking crucial nodes: pins, bearings, rollers, working parts 	X		X	X	
<div style="display: flex; align-items: center;">  <p>Do not use a high-pressure cleaner or direct stream of water to clean the hydraulic rollers, bearings, electric and electronic parts. The seals and bearings are not waterproof at high pressure.</p> </div>					
Hydraulic system					
Checking the function, tightness, mounting and worn spots of all hydraulic parts and hoses		X	X		
Hydraulic hoses – replacement: <ul style="list-style-type: none"> • Damaged external casing of the hose (mechanically or blistered) • Fluid seepage (especially the end piece) • Bumps or blisters on the hose • Deformed or corroded end piece • Loose end piece – the hose spins 	X			X	
Hydraulic hoses - replacement: <ul style="list-style-type: none"> • Expired service life of the hose 					6 years
<div style="display: flex; justify-content: space-around;">   </div>					
<p>!!! PREVENTION means removing the problem according to the plan, outside the season, without stress and comfortably before a secondary problem, an accident or a health hazard arises.</p>					

MAINTENANCE PLAN							
Perform the planned maintenance according to the instructions:							
Maintenance Task	Daily (season) (10 hour)	Once a week (50 hours)	Before season	After season	Time interval		
Bolt connections							
Visual inspection of bolt and hydraulic joints, tighten any loose joints using a corresponding torque (see the torque chart)	X			X			
Wheels – tighten all wheel nuts. <ul style="list-style-type: none"> • First time: after 10 hours of operation • Wheel replacement: after 10 hours of operation <table border="1" style="margin-left: 20px; width: 150px;"> <tr> <td style="padding: 2px;">M 22 x 1,5</td> <td style="padding: 2px;">440 Nm</td> </tr> </table>	M 22 x 1,5	440 Nm			X		100 h
M 22 x 1,5	440 Nm						
Towing lug M20x70 – 10.9, 280 Nm			X		100 h		
Tracing wheels – tighten all the nuts of the wheels. <ul style="list-style-type: none"> • First time: after 10 hours of operation • Wheel replacement: after 10 hours of operation <table border="1" style="margin-left: 20px; width: 150px;"> <tr> <td style="padding: 2px;">M 20 x 1,5</td> <td style="padding: 2px;">340 Nm</td> </tr> </table>	M 20 x 1,5	340 Nm			X		100 h
M 20 x 1,5	340 Nm						
Brake system							
Brake line and hoses – check the function, tightness, mounting and clamping, or breaking	X		X	X			
Brake components – check the function, tightness, mounting	X		X	X			
Air nozzle – drain using the draining valve		X		X			
Draining valve – check the function, clean and replace sealing			X	X			
Pipe filter – clean			X	X			
Brake/parking brake – check the function, escapement setting 25-45mm	X						
Brake levers escapement setting 25-45 mm			X		100 h		
Brake lining – check the condition of the brake lining, min. thickness of 3mm				X			
<p>!!! PREVENTION means removing the problem according to the plan, outside the season, without stress and comfortably before a secondary problem, an accident or a health hazard arises</p>							

MAINTENANCE PLAN					
Perform the planned maintenance according to the instructions:					
Maintenance Task	Denní 10 h (sezóna)	1x (50 h týden)	Před sezónou	Po sezóně	Časový interval
Wheels/axle					
Tyre pressure check 19.0/45-17, 14 PR, pressure 280 kPa		X	X	X	
Transport axle bearings – check and potential clearance adjustment (in a workshop)				X	
Checking tyre condition Visual inspection of tyre integrity, occurrence of cracks and protrusions	X		X	X	
Tracing wheels					
Tyre pressure check 31x15,5-15/ TR-07, pressure 300 kPa		X	X	X	
Wheel shaft bearings – check and potential replacement (in a workshop)				X	
Safety measures					
Lighting and safety hatched boards – check the condition, function and cleanliness	X		X		
Hazard and safety labels – check that they are installed and legible		X			
Machine lubrication plan					
Points of lubrication – lubricate according to the lubrication plan					Acc. to the plan
After season					
Entire machine					
<ul style="list-style-type: none"> • Treat and clean the machine; do not spray oil or similar agents on the plastic parts. • Store the machine away with piston-rods draws in, if possible. • Spray the piston-rods of the hydraulic cylinders with suitable anti-corrosion agents. • Check the tightness of all bolt and plug-in connections (see the torque chart). • Check for any damage of the electric cables and replace if needed. 					
Brake system					
<ul style="list-style-type: none"> • Preserve the anti-freeze fluid for air-brake systems (about 0.1l), ethanol-free, before the last ride, use fluid recommended by the tractor manufacturer. • Secure the machine against movement by wheel chocks. • Release the parking brake, release air from the air nozzle and close the brake lines. <p>The service brake must be released during winter so that it does not get stuck on the brake drum.</p>					
Points of lubrication					
<ul style="list-style-type: none"> • Grease the points of lubrication according to the lubrication plan, use grease NGLI 2 					
!!! PREVENTION means removing the problem according to the plan, outside the season, without stress and comfortably before a secondary problem, an accident or a health hazard arises					

10 MACHINE STORAGE

Long-term machine shutdown:

- Store the machine under a roof if possible.
- Store the machine on a flat and solid surface with sufficient load capacity.
- Clean the machine before storing and conserve so that it is not damaged in any way during storage. Pay special attention to all marked lubrication points and properly lubricate them according to the lubrication plan.
- Store the machine in the position with folded frames in the transport position. Store the machine on the axle and the storage leg, secure the machine against spontaneous movement using scotches or another suitable tool.
- When storing, lower the machine into the lower position using hydraulics.
- The machine must not lean on the discs as the working discs of the machine could be damaged.
- Secure the machine against access of unauthorised persons.

11 MACHINE LUBRICATION SCHEDULE

- All the lubrication points should also be lubricated at the beginning and end of the season.

MAZACÍ MÍSTO		INTERVAL	MAZACÍ PROSTŘEDEK
Connecting rod lug C50, C70, K80	Picture 33	50 h	Grease Class NGLI 2
Brake levers, brake shaft	Picture 34	250 h	

Picture 33 Lug C70

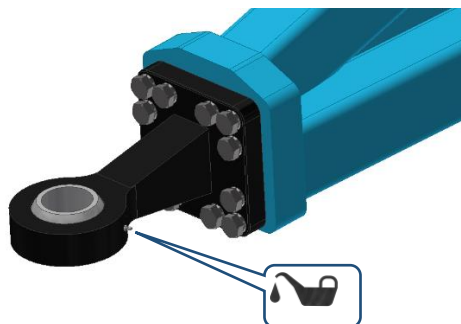

Picture 34 Brake grease cap

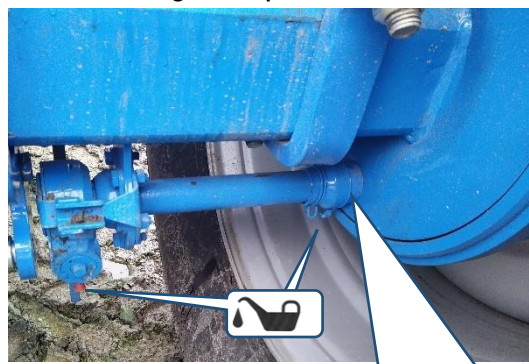

Do not lubricate excessively. Risk of grease penetrating the brake.

12 ENVIRONMENTAL PROTECTION

- Regularly check the tightness of the hydraulic system.
- Preventively replace or repair hydraulic hoses, possibly further parts of the hydraulic system showing signs of damage before oil leaks occur.
- Check the condition of hydraulic hoses and perform their timely replacement. The service life of hydraulic hoses includes the time when they were stored.
- Handle oils and greases according to valid waste laws and regulations.

13 MACHINE DISPOSAL AFTER SERVICE LIFE EXPIRY

- The operator must secure during machine disposal that steel parts and parts, in which hydraulic oil or lubricating grease moves are differentiated.
- Steel parts must be cut by the operator while observing safety regulations and handed over to the secondary raw material collection point. He must proceed with other parts according to valid laws about waste.

14 SERVICING AND WARRANTY CONDITIONS

14.1 SERVICING

Servicing is secured by the dealer after consulting with the manufacturer, possibly directly by the manufacturer. Spare parts then using the sales network by individual sellers in the entire country. Use only the spare parts according to the spare parts catalogue officially issued by the manufacturer.

14.2 WARRANTY

- 14.2.1 The manufacturer provides a warranty of 24 months for these machine parts: main frame, axle, and machine tow bar. For other parts of the machine, the manufacturer provides a warranty of 12 months. The warranty is provided from the date of sale of the new machine to the end user (consumer).
- 14.2.2 The warranty applies to hidden defects that will show in the warranty period with proper use of the machine and while fulfilling the conditions stated in the operating manual.
- 14.2.3 The warranty does not apply to wearable spare parts, i.e. regular mechanical wear and tear of replaceable parts of the working sections (shares, edges etc.).
- 14.2.4 The warranty does not apply to indirect consequences of possible damage, such as service life decrease etc.
- 14.2.5 The warranty is bound to the machine and is not void upon an owner change.
- 14.2.6 The warranty is limited to the disassembly and assembly, possibly replacement or repair of the defective part. The decision, whether to replace or repair the defective part, is up to the contractual workshop of Farmet.
- 14.2.7 During the warranty period, only the authorised servicing technician of the manufacturer may perform repairs or other interventions into the machine. In the opposite case, the warranty will not be acknowledged. This provision does not apply to the replacement of wearable spare parts (see point 14.2.3).
- 14.2.8 The warranty is conditioned by using the genuine spare parts of the manufacturer.

CZ **ES PROHLÁŠENÍ O SHODĚ**
GB **CE CERTIFICATE OF CONFORMITY**
D **EG-KONFORMITÄTSERKLÄRUNG**
F **DÉCLARATION CE DE CONFORMITÉ**
RU **СЕРТИФИКАТ СООТВЕТСТВИЯ ЕС**
PL **DEKLARACJA ZGODNOŚCI WE**

1. CZ My GB We D Wir F Nous RU Мы PL My: **Farmet a.s.**
 Jiřinková 276
 552 03 Česká Skalice
 Czech Republic
 DIČ: CZ46504931
 Tel/Fax: 00420 491 450136

CZ Vydáváme na vlastní zodpovědnost toto prohlášení. GB Hereby issue, on our responsibility, this Certificate. D Geben in alleiniger Verantwortung folgende Erklärung ab. F Publiions sous notre propre responsabilité la déclaration suivante. RU Под свою ответственность выдаем настоящий сертификат. PL Wydajemy na własną odpowiedzialność niniejszą Deklarację Zgodności.

2. CZ Strojní zařízení: - název : **Diskový podmítač**
GB Machine: - name : **Disk plough-harrow**
D Fabrikat: - Bezeichnung : **Kurzscheibenegge**
F Machinerie: - dénomination : **Déchaumeur à disques**
RU Сельскохозяйственная машина: - наименование : **Дисковый лущильник**
PL Urządzenie maszynowe: - nazwa : **Talerzowy pług podorywkowy**

- typ, type : **SOFTER**
 - model, modèle : **SF500PRO | SF600PRO | SF700PRO | SF800PRO**
 - PIN/VIN :

- CZ výrobní číslo :
 - GB serial number
 - D Fabriknummer
 - F n° de production
 - RU заводской номер
 - PL numer produkcyjny

3. CZ Příslušná nařízení vlády: č.176/2008 Sb. (směrnice 2006/42/ES). GB Applicable Governmental Decrees and Orders: No. 176/2008 Sb. (Directive 2006/42/ES). D Einschlägige Regierungsverordnungen (NV): Nr. 176/2008 Slg. (Richtlinie 2006/42/ES). F Décrets respectifs du gouvernement: n°.176/2008 du Code (directive 2006/42/CE). RU Соответствующие постановления правительства: № 176/2008 Сб. (инструкция 2006/42/ES). PL Odpowiednie rozporządzenia rządowe: nr 176/2008 Dz.U. (Dyrektywa 2006/42/WE).

4. CZ Normy, s nimiž byla posouzena shoda: GB Standards used for consideration of conformity: D Das Produkt wurde gefertigt in Übereinstimmung mit folgenden Normen: F Normes avec lesquelles la conformité a été évaluée: RU Нормы, на основании которых производилась сертификация: PL Normy, według których została przeprowadzona ocena: ČSN EN ISO 12100, ČSN EN ISO 4254-1.

CZ Schválil GB Approve by date: 01.02.2024
D Bewilligen F Approuvé
RU Утвердил PL Uchwalif

V České Skalici date: 01.02.2024

Ing. Petr Lukášek
 technický ředitel
 Technical Director

Ing. Karel Žďárský
 generální ředitel společnosti
 General Manager

Farmet a.s.
 Jiřinková 276
 552 03 Česká Skalice
 DIČ CZ46504931
 59